

# CHiNT

## **DTSU666-G Smart Meter Quick Operation Guide**

**Issue : 001-01  
Date: 2024-06**



ZTW0.464.0233

# 1 Product introduction

## 1.1 Outline and mounting dimensions

Model	Module	Dimension (L*W*H) mm	Stutle (kg)	Rail dimension
DTSU666-G Series	4	100×72×65.5	About 0.33	DIN35

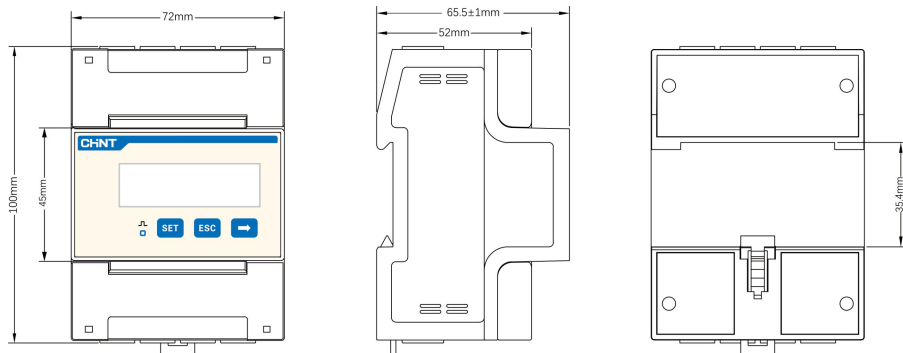

NOTE The unnoted tolerance is  $\pm 1\text{mm}$ ;  
 The appearance, size and information are subject to actual objects.

## 1.2 Product performance specification

Model	DTSU666-G
Current specification	0.25-5(80)A
Nominal voltage	3×220/380V...3×240/415V
Frequency	50/60Hz
Current measuring range	0~80A
Voltage measuring range	3×57.7/100V...3×288/500V
Accuracy class	Class B (Class 1)
Power grid system	three-phase four-wire
Baud rate	1200bps/2400bps/4800bps/9600bps (default 9600bps) /19200bps/38400bps/115200bps (customizable)
Temperature	-25°C~+55°C(nominal),-40°C~+70°C(ultimate)
Way to install	DIN35 Rail mounting
Authentication	CE,RCM,SAA,RoHS

## 2 Install

Mount the Smart Meter to a 35 mm DIN rail. Hook it into the top edge of the rail and press down until it snaps into place.

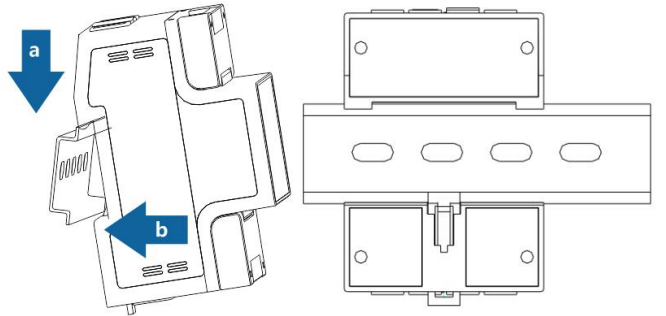

## 3 Installing cables

### 3.1 Prepare cables

Cables	Port	Port number	Type	Conductor Cross-sectional Area Range	Outer Diameter	Source
Voltage and current cables	L1 or UA、IA*	1	Multi-core outdoor copper cable	4mm <sup>2</sup> ~25m <sup>2</sup>	5mm~10mm	Prepared by the customer
	IA	3				
	L2 or UB、IB*	4				
	IB	6				
	L3 or UC、IC*	7				
	IC	9				
	N or UN	10				
Communications cable (advise)	RS485_1 A	24	Two core outdoor twisted-pair shielded wire	0.25mm <sup>2</sup> ~1.5mm <sup>2</sup>	4mm~11mm	Prepared by the customer
	RS485_1 B	25				

#### NOTE

The maximum torque of terminal screws 1, 3, 4, 6, 7, 9, and 10 is 1.7N·m. The recommended torque is 0.9N·m~1.1N·m. The maximum torque of terminal screws 11, 12, 24, and 25 is 0.4N·m. The recommended torque is 0.15N·m~0.25N·m.

## 3.2 Wiring diagram

- Three-phase four-wire

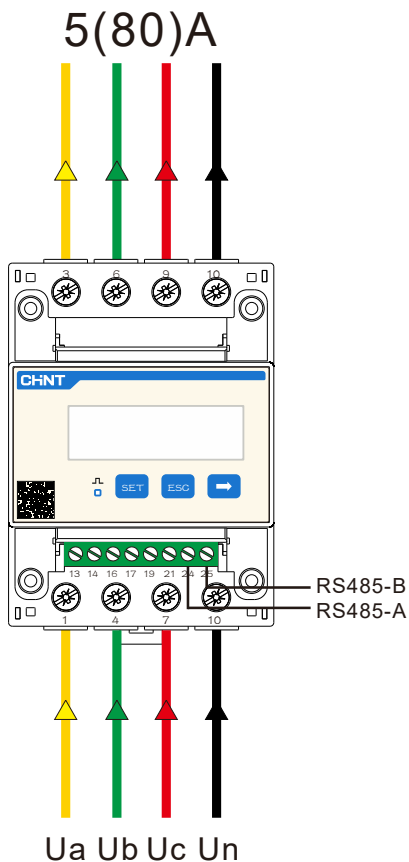















### ⚠ CAUTION

The following conditions may result in electric shock or fire. 1. Before connecting cables, ensure that the Smart Meter is not damaged in any way. 2. Please ensure that the grounding wire is securely installed. 3. Before powering on, please ensure that the wiring is correct.







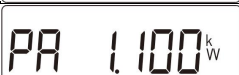



## 4 Displays project and parameter Settings

### 4.1 Display

To switch to the screen, press ESC or . Press ESC to the previous page and  to the next. When RS485 communicating, the telephone sign will flashes

No.	Display interface	Instruction
1		Total positive active energy = 10000.00kWh
2		Total inverse active energy =2345.67kWh
3		A-phase voltage =220.0V (no page for three-phase three-wire)
4		B-phase voltage =220.1V (no page for three-phase three-wire)
5		C-phase voltage =220.2V (no page for three-phase three-wire)
6		Line voltage Uab = 380.0V
7		Line voltage Ubc = 380.1V
8		Line voltage Uca = 380.2V
9		A-phase current = 5.000 A
10		B-phase current = 5.001A
11		C-phase current = 5.002A
12		Combined active power = 3.300kW
13		A-phase active power = 1.100 kW

Continue form

No.	Display interface	Instruction
14		B-phase active power = 1.100 kW
15		C-phase active power = 1.100 kW
16		Power factor PFt=1.000 (direction consistent with active power)
17		A-phase power factor PFa=1.000 (for three phases and three wires, "———" is displayed)
18		B-phase power factor PFb=1.000 (for three phases and three wires, "———" is displayed)
19		C-phase power factor PFc=1.000 (for three phases and three wires, "———" is displayed)
20		Frequency =50.001Hz
21		The communication serial port is Modbus, and the communication address is 11
22		The baud rate of the communication serial port is 9600bps
23		The communication serial port has 8 data bits, no check bit, and 1 stop bit



## 5 Diagnosis , analysis and elimination for common faults

Fault phenomenon	Reason analysis	Elimination
No display after the instrument being powered on	Incorrect wiring mode; Abnormal voltage supplied for the instrument;	1.If the wiring mode is incorrect, please connect based on the correct wiring mode (see the wiring diagram). 2.If the supplied voltage is abnormal, please supply the voltage on the instrument specification. If this is not the problem above, contact your local supplier.

## 6 Warranty and Service

The manufacturer implements three guarantees for product quality. Within 18 months from the date of delivery, if the user fully complies with the provisions of this manual and the factory seal is still intact, the instrument is found damaged during use, and the company is responsible for free repair or replacement.

## 7 Environmental protection

Dear customer:

Please help us do one thing, when this product at the end of its life, in order to protect our environment, please do a good job of recycling the product or its parts and materials. Please also dispose of materials that cannot be recycled. Thank you very much for your cooperation and support.

## 8 Statement

1. The products, services or features purchased by you are subject to the commercial contracts and terms signed with the Company, and all or part of the products, services or features described in this manual may not be included in the products purchased by you.
2. Except as otherwise agreed in the contract, the Company makes no representations or warranties, express or implied, about the contents of this specification.
3. The information in this brochure is subject to change without prior notice.
4. The Company shall not be liable for indirect losses arising from the provision, display or use of this material.

## 9 Manufacturer Information

Manufacturer	Zhejiang Chint IoT Technology Co.,Ltd.
Address	Wenzhou Daqiao Industrial Park, Beibaixiang Town, Yueqing City, Wenzhou City, Zhejiang Province, China
Tel.	+86-577-62877777
Service Hotline	+86-400-8177777
Anti counterfeiting complaints	+86-577-62789987
Website	<a href="http://aiot.chint.com">http://aiot.chint.com</a>
E-mail	<a href="mailto:ztlw@chint.com">ztlw@chint.com</a>

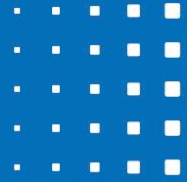

# CHiNT

## **DTSU666-G Smart Meter Quick Operation Guide**

**Issue : 001-01**  
**Date: 2024-06**



ZIW0.464.0235

# 1 Product introduction

## 1.1 Outline and mounting dimensions

Model	Wiring Method	Module	Dimension (L*W*H) mm	Subtle (kg)	Rail dimension
DTSU666-G Series	External CT access	4	100×72×65.5	About 0.35	DIN35

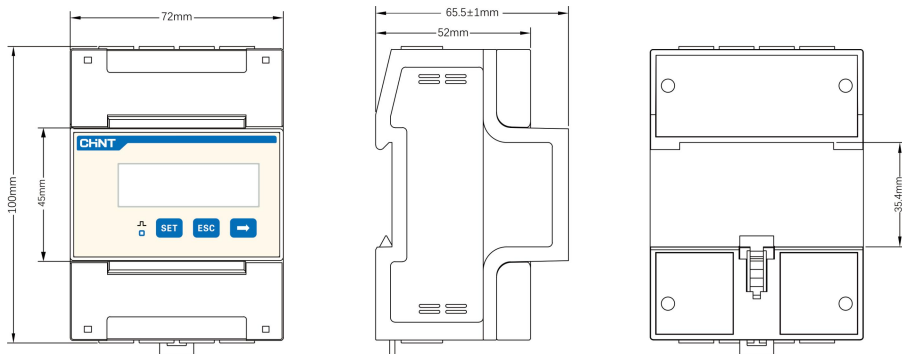

The unnoted tolerance is  $\pm 1\text{mm}$ ;

 **NOTE** The appearance, size and information are subject to actual objects.

## 1.2 Product performance specification

Model	DTSU666-G
Current specification	0.015-1.5(6)A
Nominal voltage	3×220/380V...3×240/415V
Frequency	50/60Hz
Current measuring range	0~6A
Voltage measuring range	3×57.7/100V...3×288/500V
Accuracy class	Class C (0.5S)
Power grid system	three-phase four-wire
Baud rate	1200bps/2400bps/4800bps/9600bps (default 9600bps) /19200bps/38400bps/115200bps (customizable)
Temperature	-25°C~+55°C(nominal),-40°C~+70°C(ultimate)
Way to install	DIN35 Rail mounting
Authentication	CE,RCM,SAA,RoHS

## 2 Install

Mount the Smart Meter to the 35 mm DIN rail. Hook it into the top edge of the rail and press down until it snaps into place.

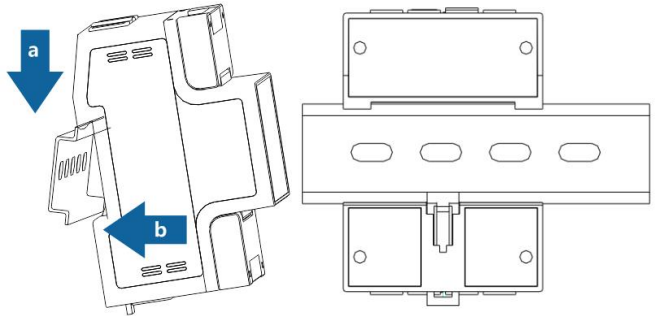

## 3 Installing cables

### 3.1 Prepare cables

Cables	Port	Port number	Type	Conductor Cross-sectional Area Range	Outer Diameter	Source
voltage cable	L1 or UA	2	Multi-core outdoor copper cable	1.5mm <sup>2</sup> ~2.5 mm <sup>2</sup>	3mm~5mm	Prepared by the customer
	L2 or UB	5				
	L3 or UC	8				
	N or UN	10				
current transformer cable	IA*	1	Multi-core outdoor copper cable	4mm <sup>2</sup> ~25mm <sup>2</sup>	5mm~10mm	Prepared by the customer or supplied with current transformers
	IA	3				
	IB*	4				
	IB	6				
	IC*	7				
	IC	9				
Communications cable (advise)	RS485_1 A	24	Two core outdoor twisted-pair shielded wire	0.25mm <sup>2</sup> ~1.5 mm <sup>2</sup>	4mm~11mm	Prepared by the customer
	RS485_1 B	25				

#### NOTE

The maximum torque of terminal screws 1, 3, 4, 6, 7, 9, and 10 is 1.7N·m. The recommended torque is 0.9N·m~1.1N·m. The maximum torque of terminal screws 2, 5, 8, 11, 12, 24, and 25 is 0.4N·m. The recommended torque is 0.15N·m~0.25N·m.

## 3.2 Wiring diagram

CT specification requirements: Accuracy class 0.5 or 0.5s, secondary side current 1A or 5A.

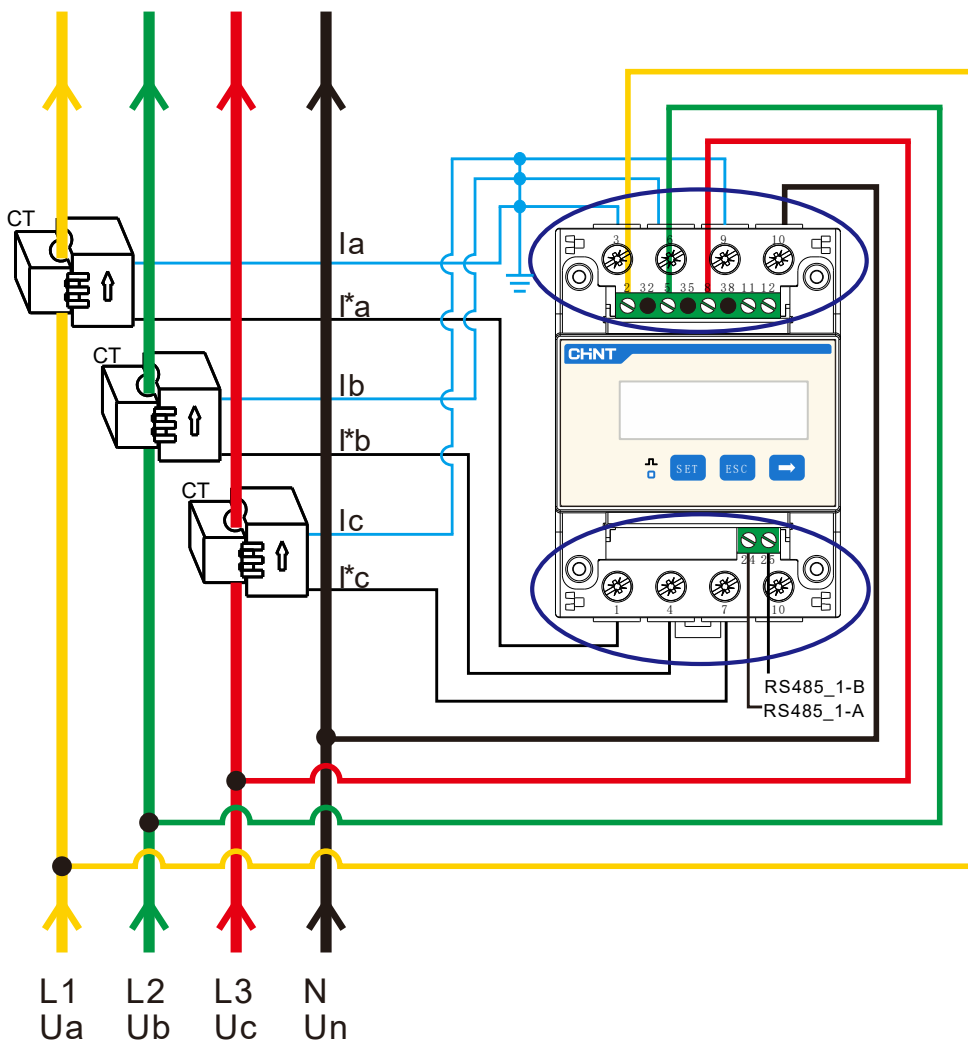















### ⚠ CAUTION

The following conditions may result in electric shock or fire. 1. Before connecting cables, ensure that the Smart Meter is not damaged in any way. 2. Please ensure that the grounding wire is securely installed. 3. Before powering on, please ensure that the wiring is correct.







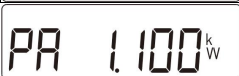



## 4 Displays project and parameter Settings

### 4.1 Display

To switch to the screen, press ESC or . Press ESC to the previous page and  to the next. When RS485 communicating, the telephone sign will flashes

No.	Display interface	Instruction
1		Total positive active energy = 10000.00kWh
2		Total inverse active energy =2345.67kWh
3		A-phase voltage =220.0V (no page for three-phase three-wire)
4		B-phase voltage =220.1V (no page for three-phase three-wire)
5		C-phase voltage =220.2V (no page for three-phase three-wire)
6		Line voltage Uab = 380.0V
7		Line voltage Ubc = 380.1V
8		Line voltage Uca = 380.2V
9		A-phase current = 5.000 A
10		B-phase current = 5.001A
11		C-phase current = 5.002A
12		Combined active power = 3.300kW
13		A-phase active power = 1.100 kW

Continue form

No.	Display interface	Instruction
14		B-phase active power = 1.100 kW
15		C-phase active power = 1.100 kW
16		Power factor PFt=1.000 (direction consistent with active power)
17		A-phase power factor PFa=1.000 (for three phases and three wires, "———" is displayed)
18		B-phase power factor PFb=1.000 (for three phases and three wires, "———" is displayed)
19		C-phase power factor PFc=1.000 (for three phases and three wires, "———" is displayed)
20		Frequency =50.001Hz
21		The communication serial port is Modbus, and the communication address is 11
22		The baud rate of the communication serial port is 9600bps
23		The communication serial port has 8 data bits, no check bit, and 1 stop bit

## 4.2 Key parameter display

Parameter	Value range	Instruction
Ct	1~9999	Current ratio, used for setting the input loop current ratio: When the current is connected to the line via the transformer, $Ct = \frac{\text{the rated current of the primary loop}}{\text{the rated current of the secondary circuit}}$ ; When the current is directly connected to the line, Ct shall be set as 1. $Ct * Pt \leq 250000.0$
Pt	0.1~999.9	Voltage ratio, used for setting the voltage ratio of the input loop; When the voltage is connected to the line via the transformer, $Pt = \frac{\text{the rated voltage of the primary loop}}{\text{the rated voltage of the secondary circuit}}$ ; When the voltage is directly connected to the line, Pt shall be set as 1.0. $Ct * Pt \leq 250000.0$
Adr1	1~247	First communication serial port Modbus protocol communication address
bPS1	1.200; 2.400; 4.800; 9.600; 19.20; 38.40; 115.2	Baud rate of the first communication serial port 1.200:1200bps; 2.400:2400bps; 4.800:4800bps; 9.600:9600bps; 19.20:19200bps; 38.40:38400bps; 115.2:115200bps



## 8 Statement

1. The products, services or features purchased by you are subject to the commercial contracts and terms signed with the Company, and all or part of the products, services or features described in this manual may not be included in the products purchased by you.
2. Except as otherwise agreed in the contract, the Company makes no representations or warranties, express or implied, about the contents of this specification.
3. The information in this brochure is subject to change without prior notice.
4. The Company shall not be liable for indirect losses arising from the provision, display or use of this material.

## 9 Manufacturer Information

Manufacturer	Zhejiang Chint IoT Technology Co.,Ltd.
Address	Wenzhou Daqiao Industrial Park, Beibaixiang Town, Yueqing City, Wenzhou City, Zhejiang Province, China
Tel.	+86-577-62877777
Service Hotline	+86-400-8177777
Anti counterfeiting complaints	+86-577-62789987
Website	<a href="http://aiot.chint.com">http://aiot.chint.com</a>
E-mail	<a href="mailto:ztlw@chint.com">ztlw@chint.com</a>

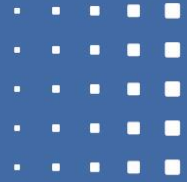

# CHiNT

## **DDSU666-G Smart Meter Quick Operation Guide**

**Issue: 015.0101-01**  
**Date: 2025-04**



ZTWO.464.0389EN

# 1 Product Description

## 1.1 Outline and mounting dimensions

Model	Wiring Method	modulus	Dimensions (L*W*H) mm	Suttle(kg)	Rail dimension
DDSU666 -G Series	External CT access	1	100×18×65.5	About 0.08	DIN35

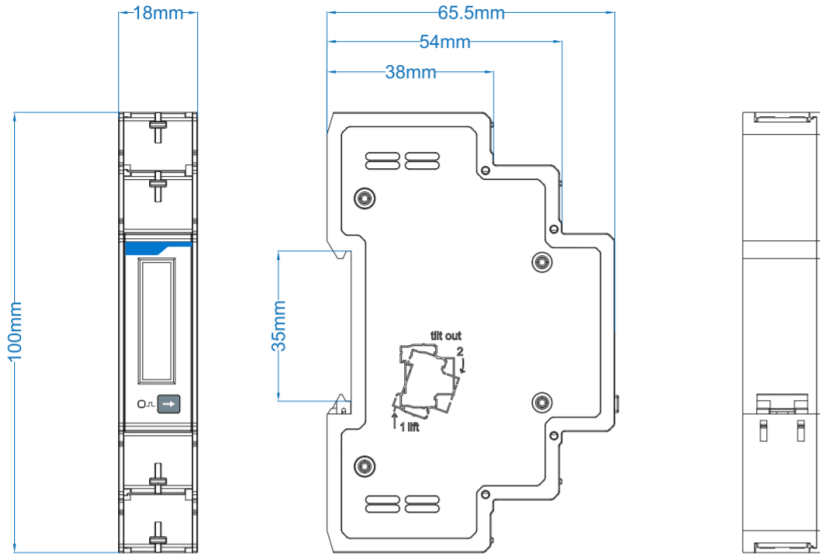

### NOTE

The unnoted tolerance is  $\pm 1\text{mm}$ ;  
The appearance, size and information are  
subject to actual objects.

## 1.2 Product performance specifications

Model	DDSU666-G
Current specification	100A/40mA
Access method	External CT access
Nominal voltage	220V...240V
Frequency	50/60Hz
Current measuring range	0~100A
Voltage measuring range	100V...288V
Accuracy class	Class B(Class 1)
Power grid system	single phase
Baud rate	1200bps/2400bps/4800bps/9600bps(default 9600bps)/ 19200bps/38400bps/115200bps(customizable)
Temperature	-25°C~+55°C(nominal),-40°C~+70°C(ultimate)
Way to install	DIN35 rail mounting
Authentication	CE,RCM,SAA,UKCA

## 1.3 Recommended current transformers

Current transformer cable length of  $6000 \pm 20\text{mm}$ , if the cable is too long can be cut short, if the cable is too short can be extended cable (up to 15000mm).

The net weight of the transformer is 0.12kg.

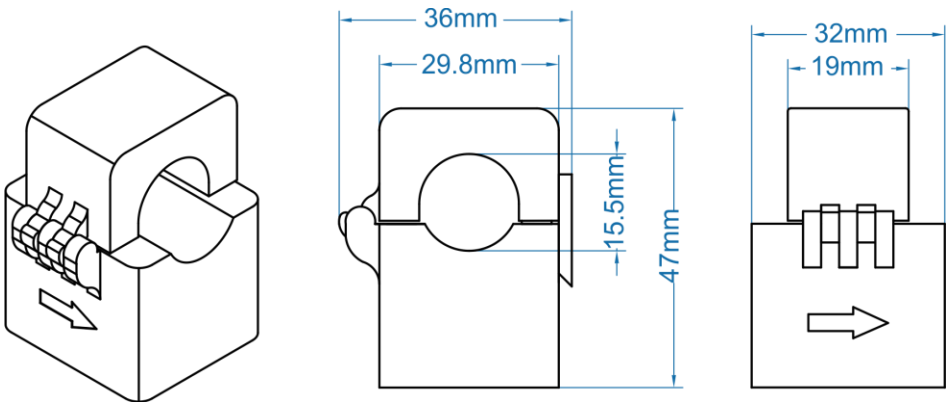

### NOTE

The unnoted tolerance is  $\pm 1\text{mm}$ ;  
The appearance, size and information are subject to actual objects.

## 2 Install

Mount the Smart Meter to the 35mm DIN rail. Hook it to the top edge of the rail and press down until it snaps into place.

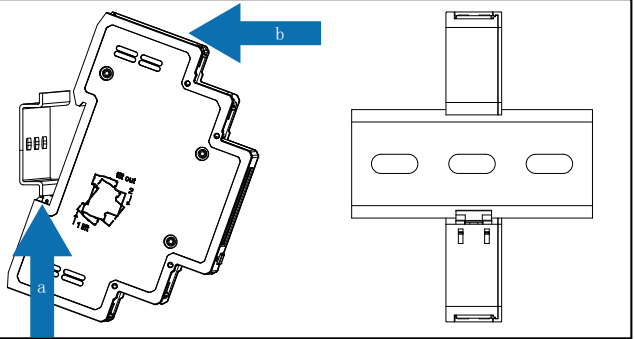

## 3 Installing cables

### 3.1 Prepare Cables

- 100A/40mA wiring - External CT Access

Cables	Port	Port number	Type	Conductor Cross-sectional Area Range	Outer Diameter	Source
Voltage Cable	L or UL	1	Multi-core Outdoor Copper Cable	4mm <sup>2</sup> ~25mm <sup>2</sup>	5mm~10mm	Prepared by the customer
	N or UN	2				
Current transformer cable(single circuit)	II*	9	/	0.25mm <sup>2</sup> ~1mm <sup>2</sup>	/	Prepared by the customer or supplied with current transformers
	II	10				

- Communications cable

Cables	Port	Port number	Type	Conductor Cross-sectional Area Range	Outer Diameter	Source
Communications cable (advise)	RS485_1 A	24	Two core outdoor twisted-pair shielded wire	0.25mm <sup>2</sup> ~1mm <sup>2</sup>	4mm~11mm	Prepared by the customer
	RS485_1 B	25				

#### NOTE

The maximum torque for terminal screws 3 and 4 is 1.7 N m, and the recommended torque is 0.9 N m to 1.1 N m. The maximum torque for terminal screws 9, 10, 24 and 25 is 0.4 N m, and the recommended torque is 0.15 N m to 0.25 N m. The wiring method shall be based on the actual object.



## 4 Displays project and parameter Settings

### 4.1 Display

The key "→" is used to switch the display interface and set the parameter disp to enable the rotating display function. When RS485 communicating, the telephone sign will flashes.

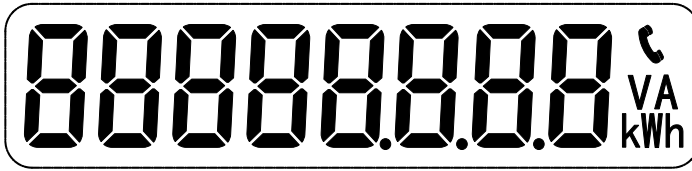

No.	Display Interface	Instruction
1		Means the positive active total electrical energy Imp, the unit is "kWh", the left picture is Imp=2.200kWh.
2		Means the reverse active total electrical energy Exp, the unit is "kWh", the left picture is Exp=2.300kWh.
3		Means the current display voltage is U, the unit is "V", the left picture is U=220.0V.
4		Means the current display current is I, the unit is "A", the left picture is I=5.000A.
5		Means the current display is the active power P, the unit is "kW", the left picture is P=1.100kW.
6		Means the current display is the power factor Ft, the left picture is Ft=1.000.
7		Means the current display is frequency F, the left picture is F=50.00Hz.
8		Means that the current communication protocol is Modbus.
9		Represents 8 data bits, no effect bit and one stop bit of the current communication protocol.
10		Means the current communication address of Modbus is 3.
11		Means the current communication baud rate is 9600.

## 4.2 Parameter setting operation example

Description of pressing key: As shown in the following flowchart, long press the button and lift it to display the screen to enter the Setting Modbus address screen. Press the button again to modify the Modbus address. The address range of the button can be set to 1-247.

### Description of pressing key

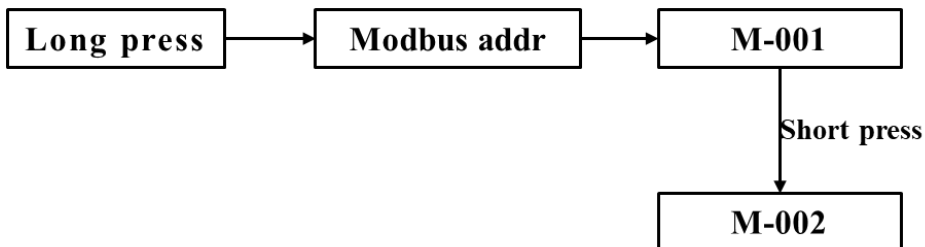

#### NOTE

- 1.If the communication is abnormal, check and set the parameters.
- 2.If the communication is single-channel, the time of key setting exit is 5s.
- 3.The range of communication address can be customized according to customer requirements, the default communication address ranges from 1 to 247.

## 5 Diagnosis, analysis and troubleshooting of common faults

Fault phenomenon	Reason analysis	Elimination
No display after the instrument being powered on	Incorrect wiring mode; Abnormal voltage supplied for the instrument;	1.If the wiring mode is incorrect, please connect based on the correct wiring mode (see the wiring diagram). 2.If the supplied voltage is abnormal, please supply the voltage on the instrument specification. If this is not the problem above, contact your local supplier.

## 6 Warranty and Service

The manufacturer implements three guarantees for product quality. Within 18 months from the date of delivery, if the user fully complies with the provisions of this manual and the factory seal is still intact, the instrument is found damaged during use, and the company is responsible for free repair or replacement.

## 7 Environmental

Dear customer:

Please help us do one thing, when this product at the end of its life, in order to protect our environment, please do a good job of recycling the product or its parts and materials. Please also dispose of materials that cannot be recycled. Thank you very much for your cooperation and support.

## 8 Statement

1. The products, services or features purchased by you are subject to the commercial contracts and terms signed with the Company, and all or part of the products, services or features described in this manual may not be included in the products purchased by you.
2. Except as otherwise agreed in the contract, the Company makes no representations or warranties, express or implied, about the contents of this specification.
3. The information in this brochure is subject to change without prior notice.
4. The Company shall not be liable for indirect losses arising from the provision, display or use of this material.

## 9 Manufacturer Information

Manufacturer	Zhejiang Chint IoT Technology Co.,Ltd.
Address	CHINT Measurement Industrial Park, No. 1 Liangce Road, Yueqing City, Wenzhou, Zhejiang Province, P.R.China.
Tel.	+86-577-62877777
Service Hotline	+86-400-8177777
Anti counterfeiting complaints	+86-577-62789987
Website	<a href="http://aiot.chint.com">http://aiot.chint.com</a>
E-mail	services@chint.com

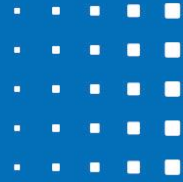

# CHiNT

## **DTSU666-G Smart Meter Quick Operation Guide**

**Issue : 001-01  
Date: 2024-06**



ZTW0.464.0247

# 1 Product introduction

## 1.1 Outline and mounting dimensions

Model	Wiring Method	Module	Dimension (L*W*H) mm	Stutle (kg)	Rail dimension
DTSU666-G Series	External CT access	4	100×72×65.5	About 0.285	DIN35

Note: Supporting transformer net weight, 100A/40mA net weight is about: 0.38kg; 250A/50mA net weight is about: 0.60kg.

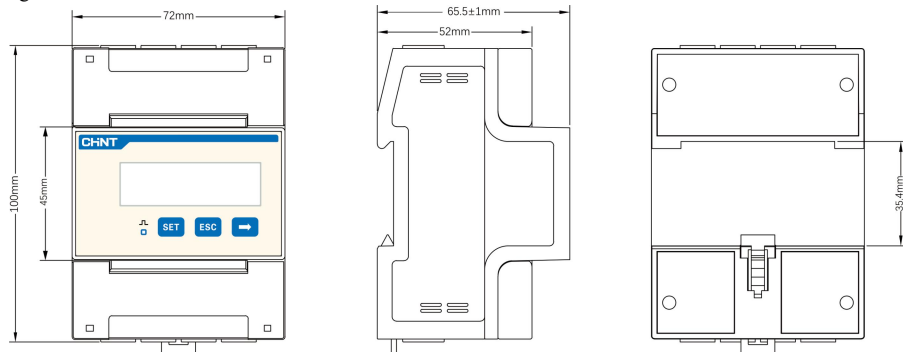

The unnoted tolerance is  $\pm 1$ mm;

**NOTE** The appearance, size and information are subject to actual objects.

## 1.2 Product performance specification

Model	DTSU666-G
Current specification	100A/40mA, 250A/50mA
Nominal voltage	3×220/380V...3×240/415V
Frequency	50/60Hz
Current measuring range	0~100A, 0~250A
Voltage measuring range	3×57.7/100V...3×288/500V
Accuracy class	Class B (Class 1)
Power grid system	three-phase four-wire
Baud rate	1200bps/2400bps/4800bps/9600bps (default 9600bps) /19200bps/38400bps/115200bps (customizable)
Temperature	-25°C~+55°C(nominal),-40°C~+70°C(ultimate)
Way to install	Rail mounting
Authentication	CE,RCM,SAA,RoHS

### 1.3 Current transformer recommended

The cable length of the current transformer is  $6000 \pm 20$ mm. If the cable is too long, cut it properly. If the cable is too short, extend it (up to 15000mm).

- 100A/40mA

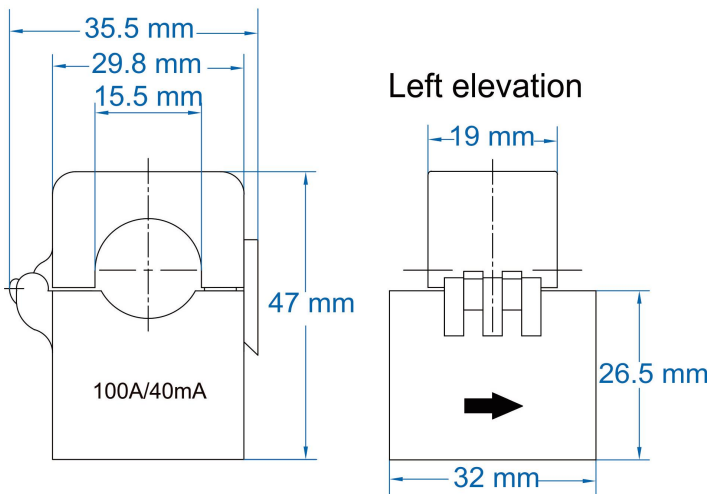

- 250A/50mA

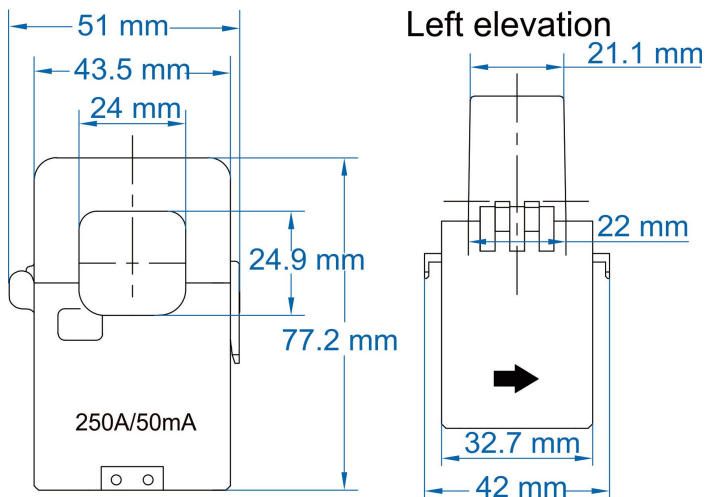

The unnoted tolerance is  $\pm 1$ mm ;  
**NOTE** The appearance, size and information are subject to actual objects.

## 2 Install

Mount the Smart Meter to a 35 mm DIN rail. Hook it into the top edge of the rail and press down until it snaps into place.

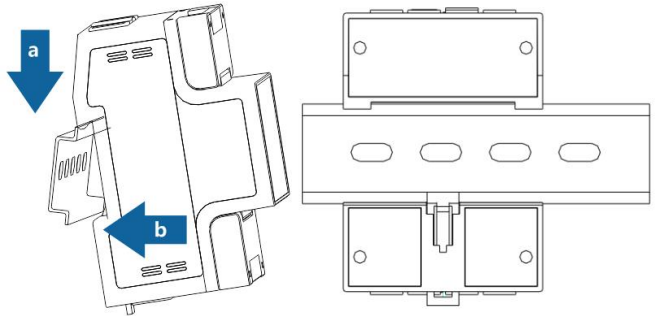

## 3 Installing cables

### 3.1 Prepare cables

Cables	Port	Port number	Type	Conductor Cross-sectional Area Range	Outer Diameter	Source
voltage cable	L1 or UA	3	Multi-core outdoor copper cable	4mm <sup>2</sup> ~25 mm <sup>2</sup>	5mm~10 mm	Prepared by the customer
	L2 or UB	6				
	L3 or UC	9				
	N or UN	10				
current transformer cable	IA*	13	/	/	/	Prepared by the customer or supplied with current transformers
	IA	14				
	IB*	16				
	IB	17				
	IC*	19				
	IC	21				
Communications cable (advise)	RS485_1 A	24	Two core outdoor twisted-pair shielded wire	0.25mm <sup>2</sup> ~1.5mm <sup>2</sup>	4mm~11 mm	Prepared by the customer
	RS485_1 B	25				

#### NOTE

The maximum torque of terminal screws 3, 6, 9, and 10 is 1.7N·m. The recommended torque is 0.9N·m~1.1N·m. The maximum torque of terminal screws 11,12,13,14,16,17,19,21, 24, and 25 is 0.4N·m. The recommended torque is 0.15N·m~0.25N·m.

## 3.2 Wiring diagram

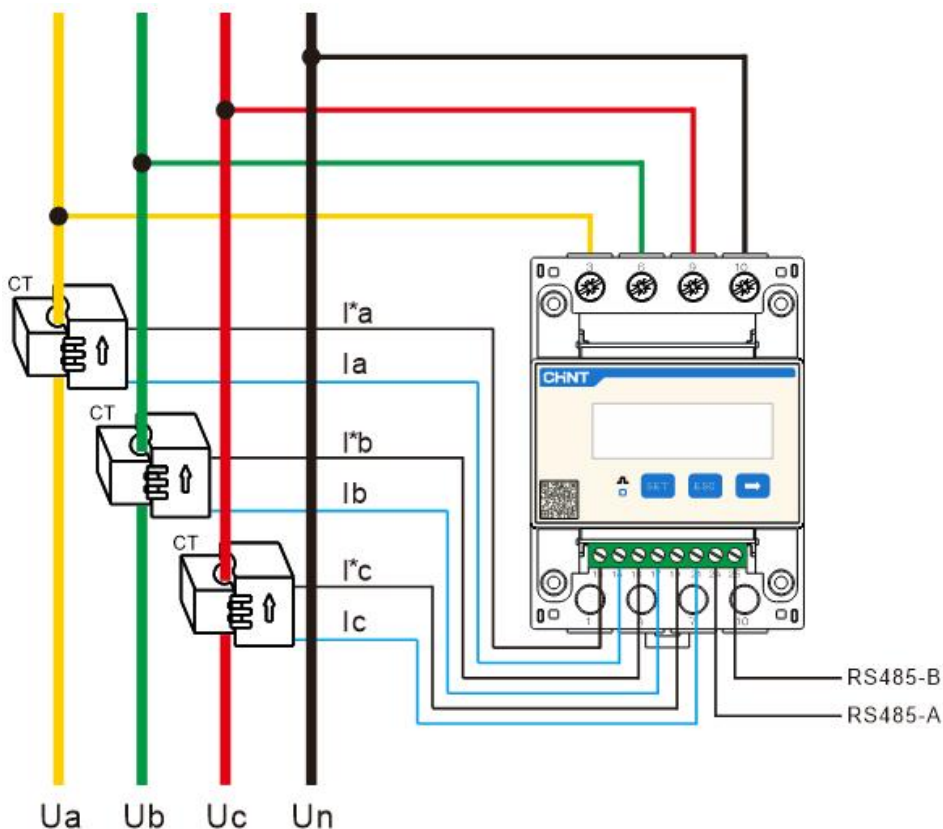















### ⚠ CAUTION

The following conditions may result in electric shock or fire. 1. Before connecting cables, ensure that the Smart Meter is not damaged in any way. 2. Please ensure that the grounding wire is securely installed. 3. Before powering on, please ensure that the wiring is correct.











## 4 Displays project and parameter Settings

### 4.1 Display

To switch to the screen, press ESC or . Press ESC to the previous page and  to the next.

No.	Display interface	Instruction
1		Total positive active energy = 10000.00kWh
2		Total inverse active energy =2345.67kWh
3		A-phase voltage =220.0V (no page for three-phase three-wire)
4		B-phase voltage =220.1V (no page for three-phase three-wire)
5		C-phase voltage =220.2V (no page for three-phase three-wire)
6		Line voltage Uab = 380.0V
7		Line voltage Ubc = 380.1V
8		Line voltage Uca = 380.2V
9		A-phase current = 5.000 A
10		B-phase current = 5.001A
11		C-phase current = 5.002A
12		Combined active power = 3.300kW
13		A-phase active power = 1.100 kW



Continue form

No.	Display interface	Instruction
14		B-phase active power = 1.100 kW
15		C-phase active power = 1.100 kW
16		Power factor PFt=1.000 (direction consistent with active power)
17		A-phase power factor PFa=1.000 (for three phases and three wires, "———" is displayed)
18		B-phase power factor PFb=1.000 (for three phases and three wires, "———" is displayed)
19		C-phase power factor PFc=1.000 (for three phases and three wires, "———" is displayed)
20		Frequency =50.001Hz
21		The communication serial port is Modbus, and the communication address is 11
22		The baud rate of the communication serial port is 9600bps
23		The communication serial port has 8 data bits, no check bit, and 1 stop bit

## 4.2 Key parameter display

Parameter	Value range	Instruction
Adr1	1~247	First communication serial port Modbus protocol communication address
bPS1	1.200; 2.400; 4.800; 9.600; 19.20; 38.40; 115.2	Baud rate of the first communication serial port 1.200:1200bps; 2.400:2400bps; 4.800:4800bps; 9.600:9600bps; 19.20:19200bps; 38.40:38400bps; 115.2:115200bps

## 4.3 Parameter setting operation example

Key description: The following figure will set the first communication parameters as an example to explain the key operation. After the meter is powered on, press SET to enter the code page. On the code screen, enter the correct password (701 by default) and press SET to enter the setting screen. On the setting screen, press  to find the parameter to be SET and press SET to enter, press  to set the parameter, press Set to proceed forward, and press ESC to exit after parameter setting. If you need to set parameters, follow the following logic.

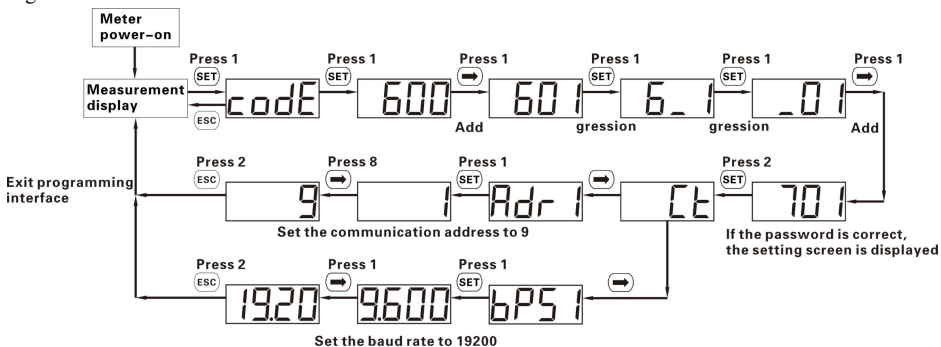

### NOTE

If the communication is abnormal, check and set parameters.

## 5 Diagnosis , analysis and elimination for common faults

Fault phenomenon	Reason analysis	Elimination
No display after the instrument being powered on	Incorrect wiring mode; Abnormal voltage supplied for the instrument;	1.If the wiring mode is incorrect, please connect based on the correct wiring mode (see the wiring diagram). 2.If the supplied voltage is abnormal, please supply the voltage on the instrument specification. If this is not the problem above, contact your local supplier.

## 6 Warranty and Service

The manufacturer implements three guarantees for product quality. Within 18 months from the date of delivery, if the user fully complies with the provisions of this manual and the factory seal is still intact, the instrument is found damaged during use, and the company is responsible for free repair or replacement.

## 7 Environmental protection

Dear customer:

Please help us do one thing, when this product at the end of its life, in order to protect our environment, please do a good job of recycling the product or its parts and materials. Please also dispose of materials that cannot be recycled. Thank you very much for your cooperation and support.

## 8 Statement

1. The products, services or features purchased by you are subject to the commercial contracts and terms signed with the Company, and all or part of the products, services or features described in this manual may not be included in the products purchased by you.
2. Except as otherwise agreed in the contract, the Company makes no representations or warranties, express or implied, about the contents of this specification.
3. The information in this brochure is subject to change without prior notice.
4. The Company shall not be liable for indirect losses arising from the provision, display or use of this material.

## 9 Manufacturer Information

Manufacturer	Zhejiang Chint IoT Technology Co.,Ltd.
Address	Wenzhou Daqiao Industrial Park, Beibaixiang Town, Yueqing City, Wenzhou City, Zhejiang Province, China
Tel.	+86-577-62877777
Service Hotline	+86-400-8177777
Anti counterfeiting complaints	+86-577-62789987
Website	<a href="http://aiot.chint.com">http://aiot.chint.com</a>
E-mail	<a href="mailto:ztwl@chint.com">ztwl@chint.com</a>