

NVF7 Series
Drive

Operation Instructions

Preface

Thank you for choosing NVF7 Series Drive.

The NVF7 Series Drive adopts speed sensorless vector control technology, which is characterized by fast load response, large low-frequency torque and strong overload ability, and realizes accurate control of equipment. This series drive has the application functions of regulated -voltage output, torque limitation, speed tracking, simple PLC, process PID, etc., and can meet the electric drive requirements of wire drawing, textile, machine tools, paper making, packaging, food, plastics, fans and pumps, and various automatic production equipment.

NVF7 Series Drive has standard RS485 communication protocol, which can meet the complex control and system integration requirements on site.

The NVF7 Series Drive fully considers the harmonic interference, dust and oil pollution of the industrial field power grid. The product has built-in anti-harmonic interference circuits, which can well suppress harmonic interference. Its modular structural design can reduce the dust and oil pollution from entering the machine, which can meet the complex environmental requirements on site.

NVF7 Series Drive is easy to operate and rich in functions, which is convenient for beginners to use and can also meet the complex application requirements of professional drive debuggers.

This manual introduces the functional characteristics and usage of NVF7 Series Drive, including product selection, installation and debugging, parameters and functions, etc. Please read the operation instructions carefully before using the drive to ensure the correct use of the drive. After reading and using the operation instructions, please keep it properly for future use.



If you encounter any difficulties or problems that cannot be solved during the use, please contact our local distributors or directly contact our professional technical personnel for help. (400 customer service hotline: 400-8177-777)

Our company reserves the right to continuously optimize and improve NVF7 Series Drive, and the information is subject to change without prior notice.



Safety Precautions

- 1 Please read the operation instructions carefully and follow all safety precautions herein before handling, installation, operation and maintenance. If it is ignored, it may cause personal injury or equipment damage, or even death.
- 2 We will not be responsible for injuries and equipment damage caused by the failure of your company or your customers to observe the safety precautions in the operation instructions.



◆ Safety Definition

Identification	Notes
 Danger	Where death or serious injury may be caused due to failure to operate as required.
 Note	Where moderate injury or minor injury may be caused, or property damage may be caused due to the failure to operate as required.



◆ Before Installation

 Danger	<ul style="list-style-type: none">◆ If the drive is damaged or with incomplete components, please do not install and run it, otherwise it may cause fire and injury!◆ Do not touch the main circuit terminal, control circuit terminal, electronic components and drive components directly with your hands!
 Note	<ul style="list-style-type: none">◆ Please check whether the nameplate information of the product is consistent with your order requirements. If not, please do not install it!◆ Please do not install the product when it is not consistent with the packing list!



◆ Installation

 Danger	<ul style="list-style-type: none">◆ Installation must be carried out by qualified personnel, otherwise it may cause electric shock!◆ Please install the drive on nonflammable objects such as metal, otherwise it may cause fire!◆ Do not put flammable objects nearby, otherwise it may cause fire!◆ Do not install it in an environment containing explosive gas, otherwise it may cause explosion!◆ Do not install it in direct sunlight, or it may cause damage to the equipment!◆ It is strictly prohibited to install it in places where water droplets may splash, such as water pipes, otherwise it may cause damage to the equipment!
 Note	<ul style="list-style-type: none">◆ When handling, do not let the operation panel and cover plate be stressed, otherwise it may cause damage to the equipment and personal injury when falling!◆ Please install it in a place that can bear the weight of the drive, otherwise it may cause damage to the equipment and personal injury when falling!◆ During installation, it is strictly forbidden to leave wire ends or metal objects in the machine, otherwise it may cause fire!

◆ Distribution

 Danger	<ul style="list-style-type: none">◇ Wiring operation must be carried out by qualified personnel, otherwise it may cause electric shock!◇ Make sure that the input power supply is completely disconnected before wiring operation, otherwise it may cause electric shock!◇ The grounding terminal of the drive must be reliably grounded, otherwise it may cause electric shock!◇ The exposed parts of the main circuit wiring cables must be wrapped with insulating tape, otherwise it may cause electric shock!◇ Do not short-circuit and B, otherwise it may cause fire and damage to the equipment!◇ The main circuit terminal and the wire terminal must be firmly connected, otherwise it may cause damage to the equipment!◇ It is strictly forbidden to connect the terminals other than R1A, R1B, R1C, R2B and R2A in the control terminals to the AC 220V signal, otherwise it may cause damage to the equipment!
 Note	<ul style="list-style-type: none">◇ Before leaving the factory, all drives have been tested for withstand voltage. It is forbidden to test the drive for withstand voltage again, otherwise it may cause damage to the equipment!◇ When the length of motor cable is more than 100 m, it is recommended to use multi-stranded wires and install AC output reactors that can suppress high-frequency oscillation. Avoid motor insulation damage, excessive leakage current and frequent protection of the drive!

◆ Operation

 Danger	<ul style="list-style-type: none">◇ Cover the cover plate before powering on, otherwise it may cause electric shock and explosion!◇ For drives that have been stored for more than 2 years, the voltage regulator shall be used to gradually boost the voltage when powering on, otherwise it may cause electric shock and explosion!◇ Do not touch the terminal with your hands when the power is on, otherwise it may cause electric shock!◇ Do not operate the drive with wet hands, otherwise it may cause electric shock!◇ After replacing the control panel, be sure to set the parameters correctly before running, otherwise it may cause damage to the equipment!◇ Non-professional technicians are forbidden to test signals during operation, otherwise it may cause personal injury or damage to the equipment!
 Note	<ul style="list-style-type: none">◇ Please confirm whether the phase number and rated voltage of the power supply are consistent with the nameplate of the product, otherwise it may cause damage to the equipment!◇ Check the wiring of the main circuit of the drive to ensure that there is no short circuit and the wiring is fastened, otherwise it may cause damage to the equipment!◇ The start and stop of the drive shall not be controlled frequently by switching it on and off, otherwise it may cause damage to the equipment!◇ In civil environment, this product may cause radio interference, in which case, additional suppression measures (reactors, filters, etc.) may be required!

◆ Maintenance

 Danger	<ul style="list-style-type: none">◇ Product maintenance, care, inspection or replacement of parts must be carried out by qualified personnel, otherwise it may cause electric shock!◇ It is strictly forbidden to leave wire ends or metal objects in the machine, otherwise it may cause fire!◇ It is forbidden to carry out maintenance, care, inspection or replacement of parts on the product with electricity, otherwise it may cause electric shock!◇ Maintenance operation can only be carried out after the power supply is disconnected for 10 minutes and the voltage of positive and negative buses is lower than 36V, otherwise it may cause electric shock!
--	--

◆ **Maintenance**

 Note	<ul style="list-style-type: none"> ◇ During maintenance, care, inspection, or part replacement of the product, try not to touch the components, otherwise it may cause electrostatic damage to the components! ◇ All pluggable components must be plugged and unplugged under the condition of power failure!
--	---

◆ **Motor And Mechanical Load**

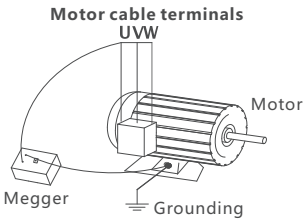
Precautions	Notes
Comparison with power frequency operation	The output voltage is PWM wave, which contains certain harmonics. Therefore, the temperature rise, noise and vibration of the motor are slightly increased compared with power frequency operation.
Low-speed running	When the drive drives the ordinary motor to run at low speed for a long time, the output torque quota needs to be reduced because of the poor heat dissipation effect of the motor. If you need to run the drive at low speed and constant torque for a long time, be sure to select the drive motor.
Electronic thermal protection value of motor	When an adaptive motor is selected, the drive can provide thermal protection for the motor. If the rated capacity of the motor and the drive does not match, be sure to adjust the protection value or take other protection measures to ensure the safe operation of the motor.
Operation at a frequency above 50Hz	If it runs beyond 50Hz, besides considering the vibration and noise increase of the motor, the speed range of the motor bearing and mechanical device must also be ensured, and prior inquiry shall be ensured.
Lubrication of mechanical devices	Mechanical devices that need lubrication, such as gearbox and gears, may be damaged due to poor lubrication effect when running at low speed for a long time, so be sure to check them in advance.
Negative torque load	For occasions such as lifting the load, negative torque often occurs, and the drive often trips due to overcurrent or overvoltage faults, in which case, it shall be considered to select brake components with appropriate parameters.
Mechanical resonance point of load device	In a certain output frequency range, the drive may encounter the mechanical resonance point of the load device, which must be avoided by setting the jump frequency.
Frequent start-stop occasions	It is suitable for starting and stopping the drive through the terminal. It is forbidden to use contactors and other switching devices on the input side of the drive for direct and frequent start-stop operation, otherwise it will cause damage to the equipment.
Motor insulation inspection before connecting the drive	<p>Before the motor is used for the first time or used after being placed for a long time, the insulation of the motor shall be checked to prevent the drive from being damaged due to the insulation failure of the motor winding. Wiring is as shown in the figure, please use 500V voltage megohmmeter when testing, and ensure that the measured insulation resistance is not less than 5MΩ.</p> <div style="text-align: center;">  <p>Motor cable terminals U V W</p> <p>Megger</p> <p>Motor</p> <p>Grounding</p> </div>

◆ Precautions For Use

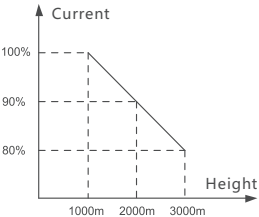
Precautions	Notes
Capacitor or pressure sensitive device for improving power factor	Since the output of the drive is PWM wave, if the output side is equipped with a capacitor to improve the power factor or a varistor for lightning protection, it will trip the drive or damage the device, so please remove it.
Use of switching devices such as contactors installed at the output terminals of the drive	If it is necessary to install switching devices such as contactors between the output of the drive and the motor, please ensure that the drive is switched on and off when there is no output, otherwise it may cause damage to the drive.
Use beyond the rated voltage value	It is not suitable to use the drive outside the allowable operating voltage range. If required, please use the corresponding step-up or step-down device for voltage transformation.
Lightning impulse protection	The drive is equipped with lightning protection device, which has certain self-protection ability for induction lightning.
Altitude and derating	<p>In areas with an altitude of more than 1000 m, derating use is required because of the poor heat dissipation effect of the drive caused by thin air. The relationship between the rated current of the drive and the altitude is shown in the figure.</p> 

◆ Scrapping Precautions

 Note	<p>The electrolytic capacitor on the main circuit and the electrolytic capacitor on the printed board may explode when burned! When plastic parts such as panels are burned, toxic gases will be generated! Please treat it as industrial waste!</p>
--	--

Catalog

Preface	I
Safety precautions	II
1 Main purpose and scope of application	1
1.1 Unpack and check	1
1.2 Main purpose	1
1.3 Scope of application	1
2 Series product model and its meanings	1
2.1 Series product model machine and its meaning	1
2.2 Product model and specification	2
3 Normal use conditions	4
3.1 Normal use environment	4
3.2 Transportation and storage conditions	4
3.3 Installation direction and installation space	4
4 Main technical parameters and performance	7
4.1 Product technical specifications	7
4.2 Heat dissipation design	8
5 Structural characteristics and working principle	9
5.1 Characteristic diagram of product main circuit	9
5.2 Product structure characteristic diagram	10
6 Appearance, installation size and weight	11
6.1 Appearance, installation size and weight	11
6.2 Flange mounting bracket	14
6.3 floor-mounted base installation	19
6.4 Operation panel, mounting bracket and dimensions	19
7 Installation, debugging and operation	21
7.1 Pre-installation inspection	21
7.2 Main circuit wiring method	21
7.3 Control circuit wiring method	29
7.4 Wiring method	31
7.5 First start-up step	35
7.6 Confirmation items of drive at initial startup	38
7.7 Usage of operation panel	39
7.8 Motor self-learning	43
7.9 Test run	45
7.10 Adjustment of control performance during test run	46
7.11 Confirmation table during test run	48

Catalog

8 Precautions in repair, maintenance and storage	49
8.1 Daily maintenance and care	49
8.2 Regular inspection and maintenance	49
8.3 Replace wearing parts	50
8.4 Storage life and precautions	50
9 Fault analysis and elimination	51
10 Warranty period and environmental protection and other legal provisions	58
10.1 Warranty period	58
10.2 Environmental protection	58
11 Product selection and ordering instructions	59
11.1 Heavy load rating and light load rating	59
11.2 Derating of drive	59
11.3 Other optional accessories	59
11.4 Selection of peripheral devices of the main circuit	59
12 Parameter details	65
12.1 F0 group Basic functions	65
12.2 F1 group start-stop control	71
12.3 F2 group motor parameters	74
12.4 F3 group vector control parameters	75
12.5 F4 group VF control parameters	79
12.6 F5 group input terminal	85
12.7 F6 group output terminal	95
12.8 F7 group keyboard and display	99
12.9 F8 group auxiliary function	103
12.10 F9 group PID function	114
12.11 FA group multi-segment instruction, simple PLC function	119
12.12 FB group communication parameters	124
12.13 Fd group optional card	126
12.14 FE group fault and protection	127
12.15 FF group user-defined function code	135
12.16 A0 group terminal expansion function	136
12.17 A5 group second motor parameters	139
12.18 U0 group monitoring parameter	142
12.19 MODBUS communication	146
13 Parameter Summary	152

1 Main purpose and scope of application

1.1 Unpacking check

After receiving the product, the following inspection shall be carried out. If there is any discrepancy, please contact your local dealer:

- ◆ Whether the external package of the drive is complete, and whether it is deformed, damaged, wet and damped, etc.;
- ◆ Open the package, please check the appearance of the drive to confirm whether there are scratches, rust, bumps, etc.;
- ◆ Please confirm whether the drive model is consistent with the product you ordered; Please confirm whether the product accessories are complete and consistent;
- ◆ If the model is inconsistent or the product has defects, do not install it. Please contact our agent distributor or our sales manager immediately.

1.2 Main purpose

The drive is mainly used for variable frequency speed regulation, torque control, enhancing operation accuracy, improving equipment power factor, overcurrent, overvoltage, overload protection and other functions of AC motor. At the same time, it can also save energy and reduce equipment noise.

1.3 Scope of application

NVF7 drive is suitable for two types of load: (1) constant torque and (2) variable torque.

2 Series product model and its meanings

2.1 Series product model machine and its meaning

The model on the product nameplate indicates the series and product specifications by the combination of letters and numbers, as shown in Figure 2.1.1.

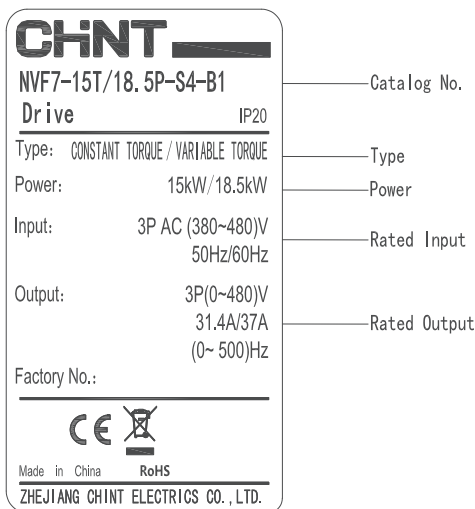
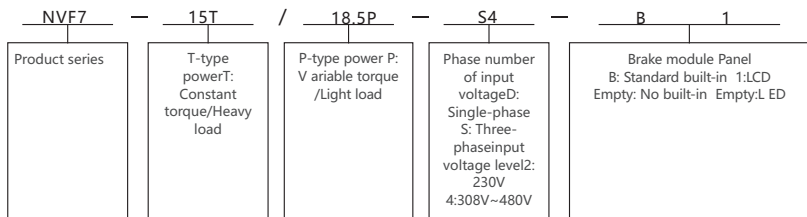

Figure 2.1.1 Nameplate Description

Figure 2.1.2 Product Model Naming Rules

2.2 Product model and specification

Table 2.2.1 Three-phase 380V Drive Model Specification Table

Drive model	Power supply capacity kVA	Input current A	Heavy load rated current A	Light load rated current A	Adapting motor (KW) (Heavy/Light load)
NVF7-0.4T/0.75P-S4-B(1)	2	1.8	1.5	2.5	0.4T/0.75P
NVF7-0.75T/1.1P-S4-B(1)	2.8	2.4	2.5	3.1	0.75T/1.1P
NVF7-1.1T/1.5P-S4-B(1)	4.1	3.7	3.1	3.7	1.1T/1.5P
NVF7-1.5T/2.2P-S4-B(1)	3.0	4.6	3.7	5.0	1.5T/2.2P
NVF7-2.2T/3.0P-S4-B(1)	3.0	6.3	5.0	7.2	2.2T/3.0P
NVF7-3.0T/4.0P-S4-B(1)	5.0	9.0	7.2	9.5	3.0T/4.0P
NVF7-4.0T/5.5P-S4-B(1)	5.9	10.5	9.5	12.2	4.0T/5.5P
NVF7-5.5T/7.5P-S4-B(1)	8.6	14.6	12.2	16.2	5.5T/7.5P
NVF7-7.5T/11P-S4-B(1)	13	19	16.2	24.6	7.5T/11P
NVF7-11T/15P-S4-B(1)	18	26	24.6	31.4	11T/15P
NVF7-15T/18.5P-S4-B(1)	25	34	31.4	37	15T/18.5P
NVF7-18.5T/22P-S4-B(1)	29	38.5	37	45	18.5T/22P
NVF7-22T/30P-S4-B(1)	34	46.5	45	60	22T/30P
NVF7-30T/37P-S4(-1)	46	62	60	75	30T/37P
NVF7-30T/37P-S4-B(1)					
NVF7-37T/45P-S4(-1)	57	76	75	90	37T/45P
NVF7-37T/45P-S4-B(1)					
NVF7-45T/55P-S4(-1)	69	92	90	110	45T/55P
NVF7-45T/55P-S4-B(1)					
NVF7-55T/75P-S4(-1)	85	113	110	150	55T/75P
NVF7-55T/75P-S4-B(1)					
NVF7-75T/90P-S4(-1)	114	157	150	176	75T/90P
NVF7-75T/90P-S4-B(1)					
NVF7-90T/110P-S4(-1)	133	180	176	210	90T/110P
NVF7-90T/110P-S4-B(1)					
NVF7-110T/132P-S4(-1)	160	214	210	253	110T/132P
NVF7-110T/132P-S4-B(1)					
NVF7-132T/160P-S4(-1)	195	256	253	300	132T/160P
NVF7-160T/185P-S4(-1)	236	307	300	340	160T/185P
NVF7-185T/200P-S4(-1)	267	345	340	380	185T/200P
NVF7-200T/220P-S4(-1)	305	430	380	420	200T/220P
NVF7-220T/250P-S4(-1)	350	477	420	470	220T/250P
NVF7-250T/280P-S4(-1)	420	526	470	520	250T/280P
NVF7-280T/315P-S4(-1)	450	605	520	600	280T/315P

Table 2.2.2 Three-phase 230V Drive Model Specification Table

Drive model	Power supply capacity kVA	Input current A	Heavy load rated current A	Light load rated current A	Adapting motor (KW) (Heavy/Light load)
NVF7-0.4T/0.75P-S2-B(1)	1.1	2.4	2.3	4.0	0.4T/0.75P
NVF7-0.75T/1.1P-S2-B(1)	2.1	4.6	4.0	5.1	0.75T/1.1P
NVF7-1.1T/1.5P-S2-B(1)	2.9	6.3	5.1	7.0	1.1T/1.5P
NVF7-1.5T/2.2P-S2-B(1)	4.2	9	7.0	9.6	1.5T/2.2P
NVF7-2.2T/3.0P-S2-B(1)	5.3	11.4	9.6	12.2	2.2T/3.0P
NVF7-3.0T/4.0P-S2-B(1)	10.2	22	12.2	16.2	3.0T/4.0P
NVF7-4.0T/5.5P-S2-B(1)	14.8	32	16.2	24.6	4.0T/5.5P
NVF7-5.5T/7.5P-S2-B(1)	19.1	39	24.6	31.4	5.5T/7.5P
NVF7-7.5T/9.5P-S2-B(1)	13	44	31.4	37	7.5T/9.5P
NVF7-9.5T/11P-S2-B(1)	20	51	37	45	9.5T/11P
NVF7-11T/15P-S2-B(1)	27	59	45	60	11T/15P
NVF7-15T/18.5P-S2(-1)	32	89	60	75	15T/18.5P
NVF7-15T/18.5P-S2-B(1)					
NVF7-18.5T/22P-S2(-1)	41	106	75	90	18.5T/22P
NVF7-18.5T/22P-S2-B(1)					
NVF7-22T/30P-S2(-1)	51	139	90	110	22T/30P
NVF7-22T/30P-S2-B(1)					
NVF7-30T/37P-S2(-1)	65	144	110	152	30T/37P
NVF7-30T/37P-S2-B(1)					
NVF7-37T/45P-S2(-1)	75	164	152	176	37T/45P
NVF7-37T/45P-S2-B(1)					
NVF7-45T/55P-S2(-1)	90	202	176	210	55T/75P
NVF7-45T/55P-S2-B(1)					

Table 2.2.3 Single-phase 230V Drive Model Specification Table

Drive model	Power supply capacity kVA	Input current A	Heavy load rated current A	Light load rated current A	Adapting motor (KW) (Heavy/Light load)
NVF7-0.4T-D2-B(1)	1.1	5.0	2.3	-	0.4T
NVF7-0.75T-D2-B(1)	2.1	9.5	4.0	-	0.75T
NVF7-1.5T-D2-B(1)	2.9	15.5	7.0	-	1.5T
NVF7-2.2T-D2-B(1)	5.3	20	9.6	-	2.2T
NVF7-3.0T-D2-B(1)	6.5	26	12.2	-	3.0T
NVF7-4.0T-D2-B(1)	7.5	32	16.2	-	4.0T

3 Normal use conditions

3.1 Normal use environment

- 1) It shall be installed indoors or inside the cabinet
- 2) Power supply overvoltage level III
- 3) Ambient temperature and relative humidity

Constant torque drive: $-10^{\circ}\text{C} \sim +40^{\circ}\text{C}$, derated between $+40^{\circ}\text{C}$ and $+50^{\circ}\text{C}$, derated by 1% of rated power for every 1°C temperature rise.

The maximum relative humidity of air shall not exceed 90% ($+20^{\circ}\text{C}$) and 50% ($+40^{\circ}\text{C}$), and the change rate of relative humidity shall not exceed 5% per hour, and no condensation shall occur.

Dust-proof and waterproof grade Ip20

4) Environmental pollution below 2

5) Please install the drive in the following places:

In places without oil mist, corrosive gas, flammable gas and dust, foreign materials such as metal powder, oil and water shall not enter the drive. In places where there are no stinging substances and perishable materials, where there are no harmful gases and liquids, where there is little salt erosion and where there is no direct sunlight, do not install the drive on flammable materials such as wood.

6) Altitude

When rated output, the altitude of the installation and use place shall not exceed 1000m.

It shall be derated in areas with an altitude of more than 1000 m, and it shall be derated at a rate of 10% for every 1000m altitude increase. The highest altitude of the installation and use site shall not exceed 3000m.

7) Vibration resistance

5~8.5Hz, displacement 3.5mm; 8.5~200Hz, acceleration is not greater than 5.9m/s².

3.2 Transportation and storage conditions

- 1) Please transport and store the product according to the transportation and storage conditions, and the storage temperature and humidity shall meet the requirements;
- 2) Avoid transportation and storage in places prone to rain, direct sunlight, strong electric field, strong magnetic field and strong vibration;
- 3) Avoid storing the product for more than 3 months. If the storage time is too long, please carry out strict protection and necessary inspection;
- 4) Please pack the product and improve it before vehicle transportation. Closed boxes must be used for long-distance transportation;
- 5) It is strictly forbidden to transport this product together with articles that may affect or damage the product;
- 6) Please use professional loading and unloading equipment to handle large-size or heavy-weight products;
- 7) When handling by hand, be sure to hold the product shell tightly to avoid the product parts falling off, otherwise it may cause injury;
- 8) When handling the product, be sure to handle it with care, and pay attention to your step at any time to prevent tripping or falling;
- 9) When the equipment is hoisted by lifting tools, it is forbidden to stand and stay under the equipment.

3.3 Installation direction and installation space

In order to ensure the cooling effect of the product during working, please be sure to install it vertically.

- ◆ Installation space and direction requirements

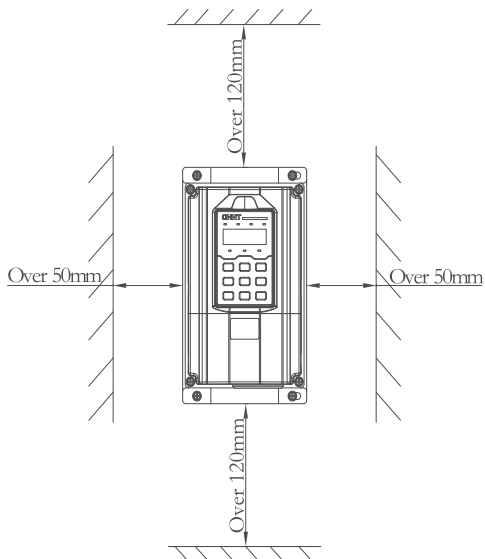

Figure 3.2.1 Installation Space of Single Machine

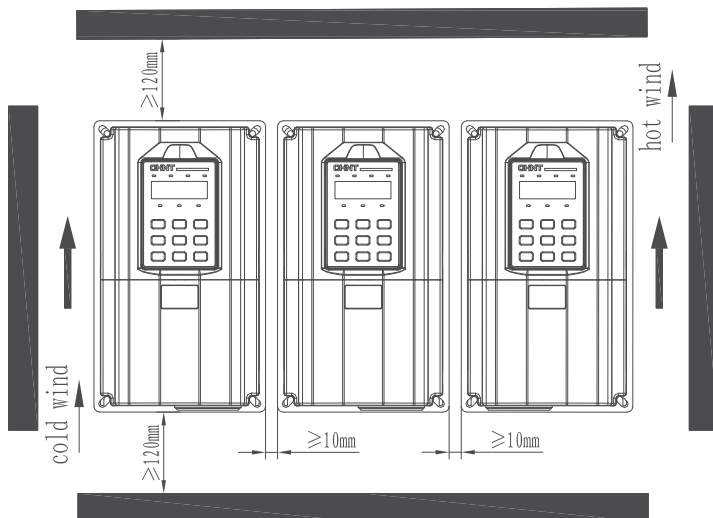

Figure 3.2.2 Parallel Installation of Multiple Machines

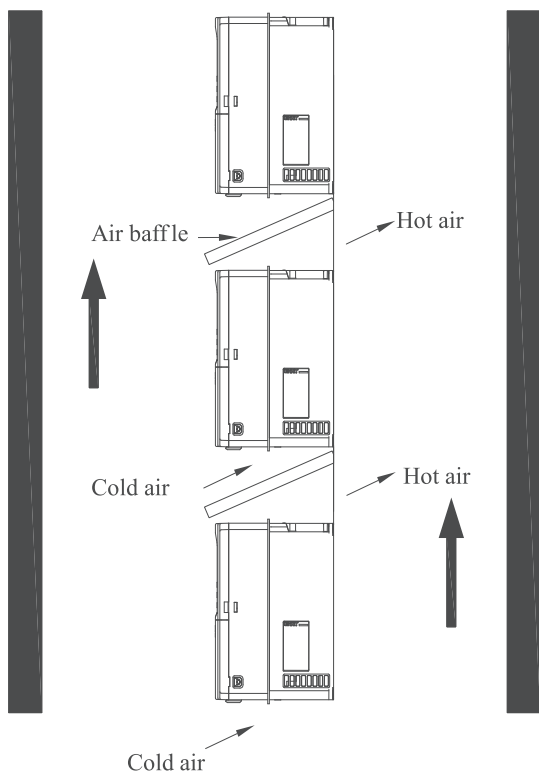

Figure 3.2.3 Vertical Installation of Multiple Machines

4 Main technical parameters and performance

4.1 Product technical specifications

Table 4.1.1 Technical Specifications of NVF7 Drive

Items		Item description
Input	Rated voltage	Three-phase (380-480)V; Three-phase 230V Single-phase 230V
	Frequency	50Hz/60Hz
	Voltage range	Three-phase 380V(-15%)~480V(+ 10%) Three-phase 230V(±15%) Single-phase 230V(±15%)
	Frequency range	(47~63)Hz
Output	voltage	0~ rated input voltage
	Frequency	(0-500) Hz
	Overload capacity	T-type: 150% rated current for 1 min and 180% rated current for 10s P-type: 120% rated current for 1 min and 150% rated current for 1 s
Main control performance	Control mode	PG-free vector control (SVC); PG vector control (FVC); V/F control;
	Modulation mode	Space vector PWM modulation
	Starting torque	SVC: 150% rated torque at 0.25 Hz FVC: 180% rated torque at 0 Hz V/F: 150% rated torque at 0.5 Hz
	Frequency resolution	Digital setting: 0.01Hz; Analog setting: maximum frequency x 0.5%
	Torque boost	Automatic torque boost, manual torque lifting
	V/F curve	Linear V/F curve, VF complete separation mode, VF semi-separation mode, multi-point V/F curve mode
	Acceleration and deceleration curve	Linear acceleration and deceleration (4 types)
	Automatic current limiting	Automatically limit the current during operation to prevent frequent overcurrent fault tripping
Customization function	Jog	Jog frequency range: (0.10~50.00) Hz Jog acceleration and deceleration time (0.1-6000.0)s
	Multi-speed running	Multi-speed running is realized through control terminals
Peripheral interface characteristics	Run command channel	Operation panel setting, control terminal setting and communication control setting, which can be switched in multiple ways
	Digital input	5 multi-function digital programmable inputs, including one HDI high-speed pulse input
	Digital output	1 multi-function digital programmable output, which can be set as high-speed pulse output or open-collector output
	Analog input	2 analog signal inputs Optional (0~20) mA, (4~20) mA current signal input or (0~10) V voltage signal input
	Analog output	2 analog signal outputs You can select (0~20) mA, (4~20) mA current output or (0~10) V voltage output respectively, which can realize the output of physical quantities such as set frequency and output frequency

Items		Item description
Peripheral interface characteristics	Relay output	2 relay outputs, including one normally open and normally closed conversion output and one normally open output. Contact capacity: NO 5A, NC 3A, 250V (AC)
	RS485 communication interface	1-way, supporting Modbus protocol
LED operation panel	LED display	It can display more than 20 parameters such as set frequency, output frequency, output voltage and output current
	Key lock	All or part of the keys are locked
	Function selection	Define the scope of some keys to prevent mis-operation
LCD operation panel (optional)	LCD display	2.4-in, resolution 320*240
	Language	Display in Chinese and English (English by default)
	Indicator	1 state indicator
Protection function	It has the protection functions such as overcurrent protection, overvoltage protection, undervoltage protection, overheat protection, overload protection and open-phase protection	
Structure	Protection grade	IP20
	Cooling mode	Axial DC fan cooling
Installation mode	Wall-mounted flange lamp	
Efficiency	≥ 93% for 37kW and below ; ≥95% for 45 kW and above	

4.2 Heat dissipation design

The heat dissipation design (calorific value and emission) of this product is shown in the following table.

Table 4.2.1 Thermal Design Parameters

Shell frame	Drive model	Calorific value/kW	Emission/CFM
T2	NVF7-0.4T/0.75P-S4-B(1)	0.046	-
	NVF7-0.75T/1.1P-S4-B(1)	0.057	-
	NVF7-1.1T/1.5P-S4-B(1)	0.068	-
	NVF7-1.5T/2.2P-S4-B(1)	0.074	9
	NVF7-2.2T/3.0P-S4-B(1)	0.093	9
	NVF7-3.0T/4.0P-S4-B(1)	0.100	9
	NVF7-4.0T/5.5P-S4-B(1)	0.125	20
	NVF7-5.5T/7.5P-S4-B(1)	0.189	24
T3	NVF7-7.5T/11P-S4-B(1)	0.24	30
	NVF7-11T/15P-S4-B(1)	0.37	40
T4	NVF7-15T/18.5P-S4-B(1)	0.42	42
T5	NVF7-18.5T/22P-S4-B(1)	0.47	52
	NVF7-22T/30P-S4-B(1)	0.60	57.5
T6	NVF7-30T/37P-S4-B(1)	0.69	118.5
	NVF7-37T/45P-S4-B(1)	0.81	118.5
T7	NVF7-45T/55P-S4-B(1)	1.10	123
	NVF7-55T/75P-S4-B(1)	1.22	123
	NVF7-75T/90P-S4-B(1)	1.54	219
T8	NVF7-90T/110P-S4-B(1)	1.78	288
	NVF7-110T/132/P-S4-B(1)	2.10	343
	NVF7-132T/160P-S4-B(1)	2.65	547
T9	NVF7-160T/185P-S4-B(1)	2.90	627
	NVF7-185T/200P-S4-B(1)	3.72	630
T10	NVF7-200T/220P-S4-B(1)	3.95	635
	NVF7-220T/250P-S4-B(1)	5.03	735
T11	NVF7-250T/280P-S4-B(1)	5.23	746
	NVF7-280T/315P-S4-B(1)	5.42	796

5 Structural characteristics and working principle

5.1 Characteristic diagram of product main circuit

The main circuit of NVF7 Series Drive includes rectifier bridge, precharge circuit, DC bus support capacitor, brake module, drive bridge and other devices and circuits. The topology diagram of the main circuit is shown below.

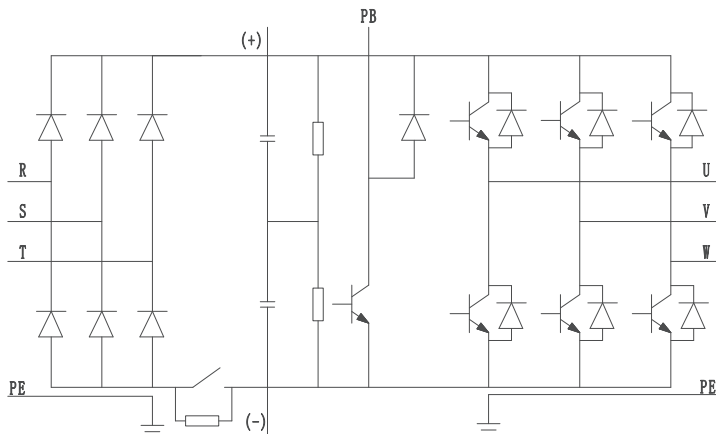

Figure 5.1.1 Schematic Diagram of Main circuit below NVF 7-15T/18.5P (Inclusive)

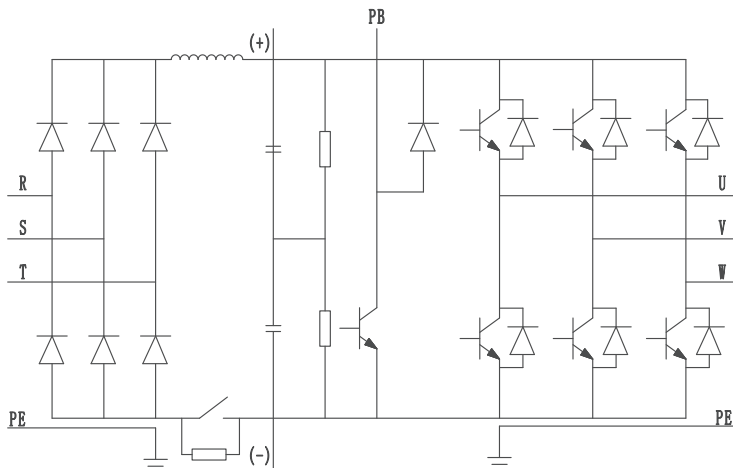

Figure 5.1.2 Schematic Diagram of Main Circuit of NVF 7-18.5t/22p or Above

5.2 Product structure characteristic diagram

NVF7 has two types of material structure, the model of 22T/30P and below is of plastic shell structure, and the model of 30T/37P and above is of sheet metal structure. As shown in the figure below:

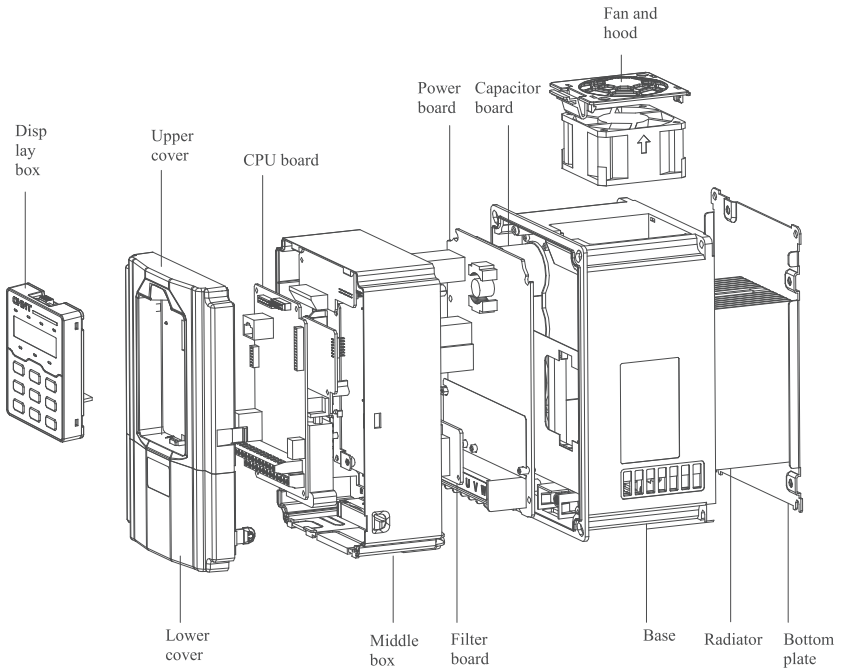

Figure 5.2.1 Structural Characteristics of NVF7 Drive

6 Appearance, installation size and weight

6.1 Appearance, installation size and weight

Table 6.1.1 Three-phase 380V drive shell frame and model

Housing frame	Drive type
T2	NVF7-0.4T/0.75P-S4-B(1)
	NVF7-0.75T/1.1P-S4-B(1)
	NVF7-1.1T/1.5P-S4-B(1)
	NVF7-1.5T/2.2P-S4-B(1)
	NVF7-2.2T/3.0P-S4-B(1)
	NVF7-3.0T/4.0P-S4-B(1)
	NVF7-4.0T/5.5P-S4-B(1)
	NVF7-5.5T/7.5P-S4-B(1)
T3	NVF7-7.5T/11P-S4-B(1)
	NVF7-11T/15P-S4-B(1)
T4	NVF7-15T/18.5P-S4-B(1)
T5	NVF7-18.5T/22P-S4-B(1)
	NVF7-22T/30P-S4-B(1)
T6	NVF7-30T/37P-S4-B(1)
	NVF7-37T/45P-S4-B(1)
T7	NVF7-45T/55P-S4-B(1)
	NVF7-55T/75P-S4-B(1)
T8	NVF7-75T/90P-S4-B(1)
	NVF7-90T/110P-S4-B(1)
	NVF7-110T/132P-S4-B(1)
T9	NVF7-132T/160P-S4(-1)
	NVF7-160T/185P-S4(-1)
T10	NVF7-185T/200P-S4(-1)
	NVF7-200T/220P-S4(-1)
T11	NVF7-220T/250P-S4(-1)
	NVF7-250T/280P-S4(-1)
	NVF7-280T/315P-S4(-1)

Table 6.1.2 Three-phase 230V drive shell frame and model

Housing frame	Drive type
T2	NVF7-0.4T/0.75P-S2-B(1)
	NVF7-0.75T/1.1P-S2-B(1)
	NVF7-1.1T/1.5P-S2-B(1)
	NVF7-1.5T/2.2P-S2-B(1)
	NVF7-2.2T/3.0P-S2-B(1)
	NVF7-3.0T/4.0P-S2-B(1)
T3	NVF7-4.0T/5.5P-S2-B(1)
	NVF7-5.5T/7.5P-S2-B(1)
T4	NVF7-7.5T/9.5P-S2-B(1)
T5	NVF7-9.5T/11P-S2-B(1)
	NVF7-11T/15P-S2-B(1)

Housing frame	Drive type
T6	NVF7-15T/18.5P-S2(-1)
	NVF7-15T/18.5P-S2-B(1)
	NVF7-18.5T/22P-S2(-1)
	NVF7-18.5T/22P-S2-B(1)
T7	NVF7-22T/30P-S2(-1)
	NVF7-22T/30P-S2-B(1)
	NVF7-30T/37P-S2(-1)
	NVF7-30T/37P-S2-B(1)
T8	NVF7-37T/45P-S2(-1)
	NVF7-37T/45P-S2-B(1)
	NVF7-45T/55P-S2(-1)
	NVF7-45T/55P-S2-B(1)

Table 6.1.3 Single phase 230V drive shell frame and model

Housing frame	Drive type
T2	NVF7-0.4T-D2-B(1)
	NVF7-0.75T-D2-B(1)
	NVF7-1.5T-D2-B(1)
	NVF7-2.2T-D2-B(1)
	NVF7-3.0T-D2-B(1)
T3	NVF7-4.0T-D2-B(1)

The outline installation of product shell frame is as follows:

- ◆ T2~T5

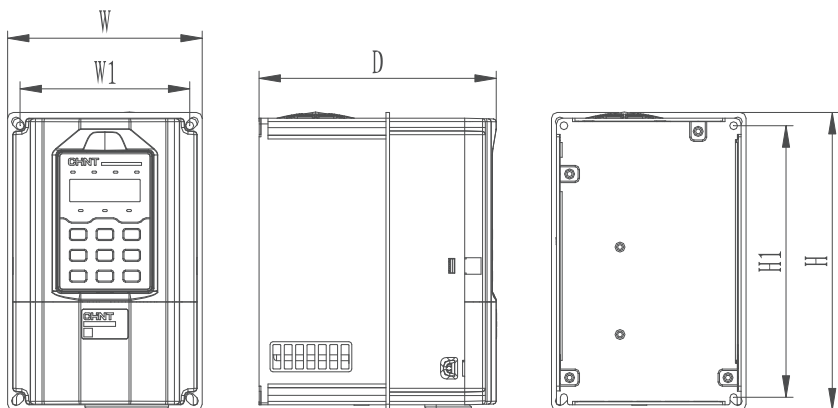
Figure 6.1.1 Installation Dimensions of T2-T5 Shell Frame Outline

◆ T6~T7

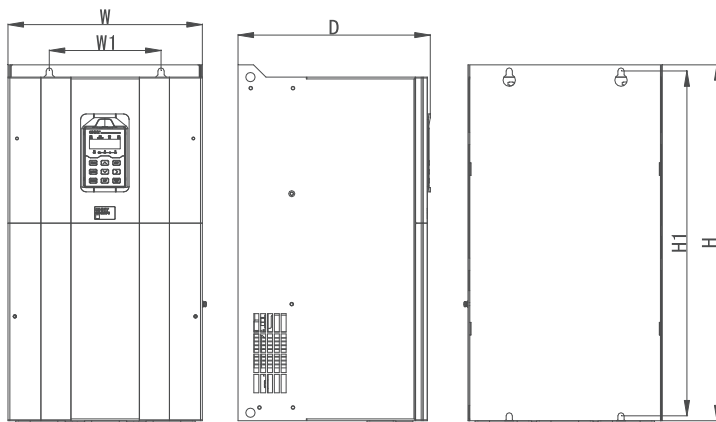

Figure 6.1.2 Installation Dimensions of T6-T7 Shell Frame Outline

◆ T8~T11

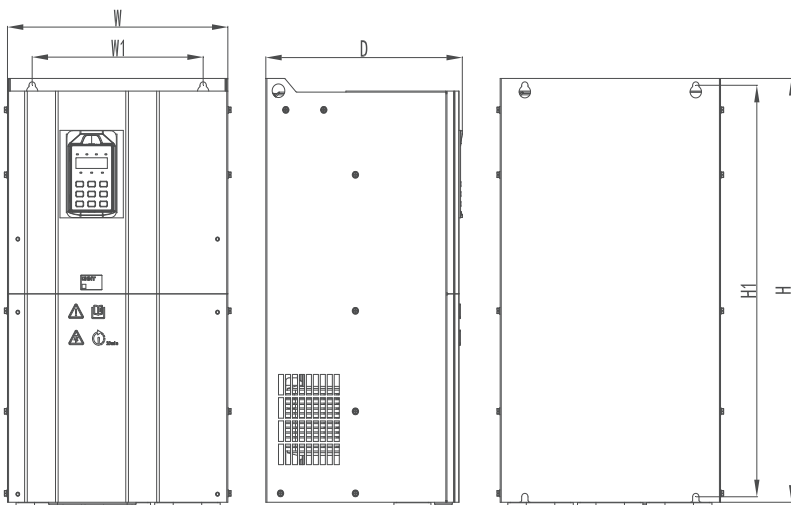

Figure 6.1.3 Installation Dimensions of T8-T11 Shell Frame Outline

- ◆ The product outline, installation size and weight are summarized as follows:

Table 6.1.4 Product shape, installation dimensions and weight

shell frame	Overall dimensions in mm			Mounting hole position mm		Weight kg	Mounting holesd	note
	W	H	D	W1	H1			
T2	136.9	207.5	166.8	119.4	189.4	2.5	∅ 5	
T3	152	262	186.4	129	239	3.7	∅ 5.5	
T4	187	288	185.9	166	269	5.5	∅ 6.3	
T5	218.4	358.5	223.6	196	335.5	11	∅ 6.8	
T6	270	466	268.1	223	443	21	∅ 10	
T7	313	580	309.6	180	562	38	∅ 10	
T8	348	620	310.3	270	602	49	∅ 10	
T9	400	915	332	320	891	84	∅ 11	
T10	400	915	362	320	891	90	∅ 11	
T11	550	1100	423.5	400	1070	118	∅ 14	

6.2 Flange mounting bracket

There are 3 installation methods for NVF7 Series Drives, namely wall-mounted installation, flange installation and floor-mounted installation, among which T2-T11 support wall-mounted installation and T2-T10 flange installation.

Table 6.2.1 Installation Dimensions of Flange of NVF 7 Series Drive

shell frame	Flange Kit No.
T2	FL-T2-01
T3	FL-T3-01
T4	FL-T4-01
T5	FL-T5-01
T6	FL-T6-01
T7	FL-T7-01
T8	FL-T8-01
T9	FL-T9-01
T10	(The same set of flange parts with different mounting dimensions after the whole machine is assembled.)
T11	Not support flange installation

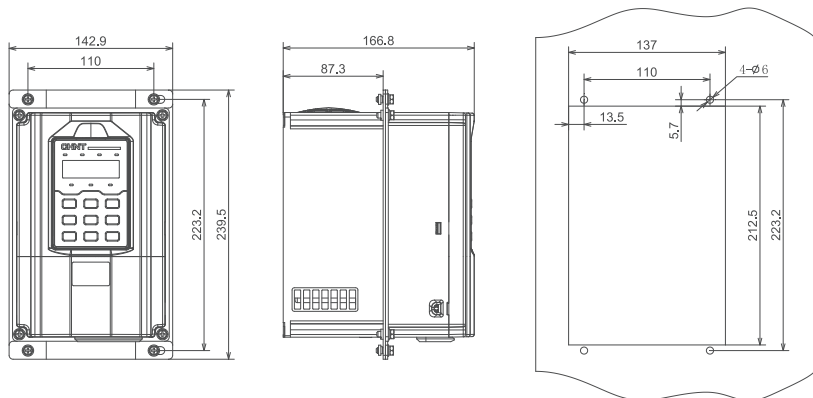

Figure 6.2.1 Schematic of T2 Flange Kit

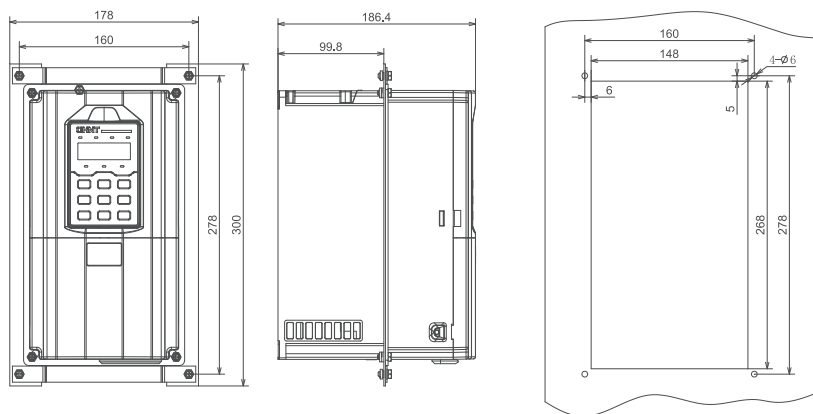

Figure 6.2.2 Schematic diagram of T3 flange kit

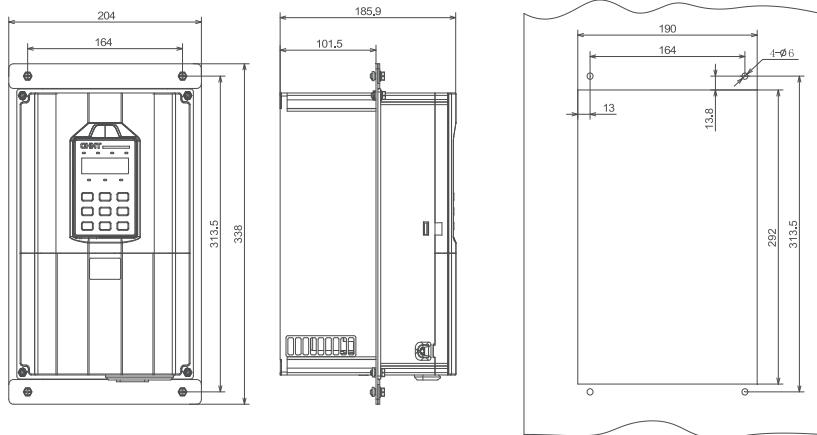

Figure 6.2.3 Schematic diagram of T4 flange kit

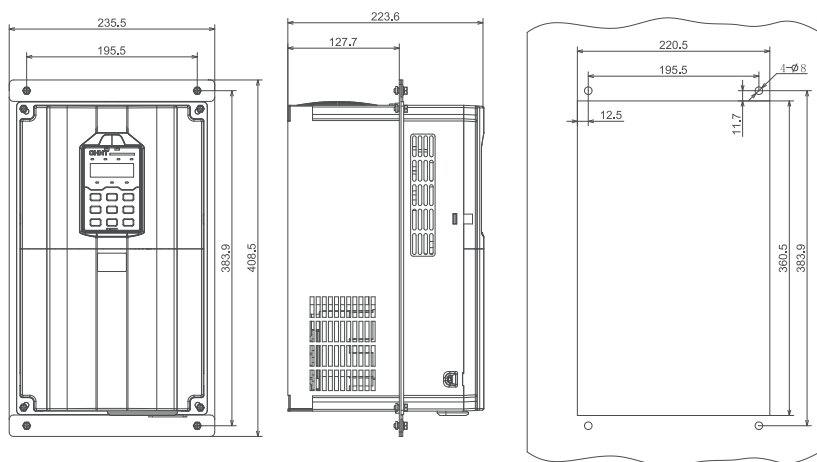

Figure 6.2.4 Schematic diagram of T5 flange kit

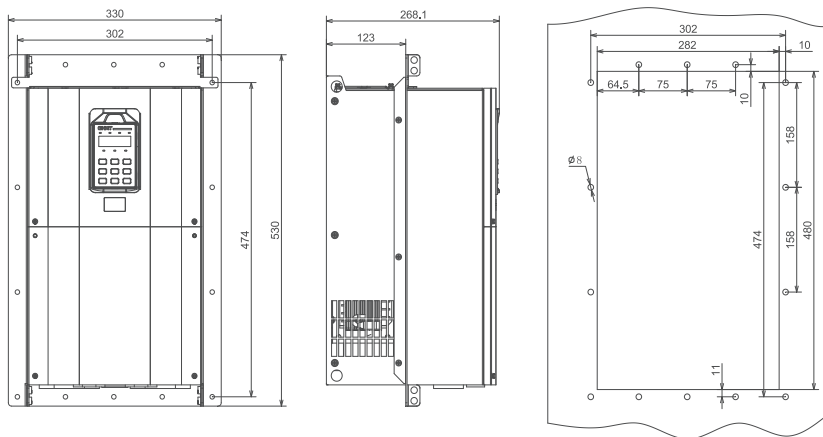

Figure 6.2.5 Schematic diagram of T6 flange kit

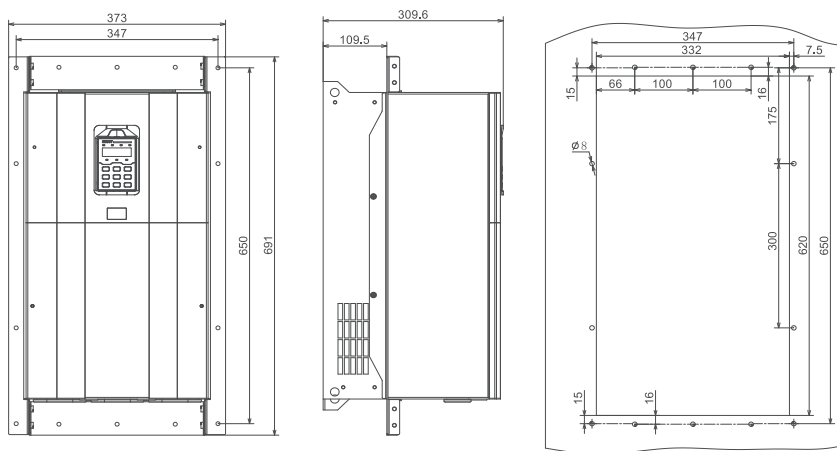

Figure 6.2.6 Schematic diagram of T7 flange kit

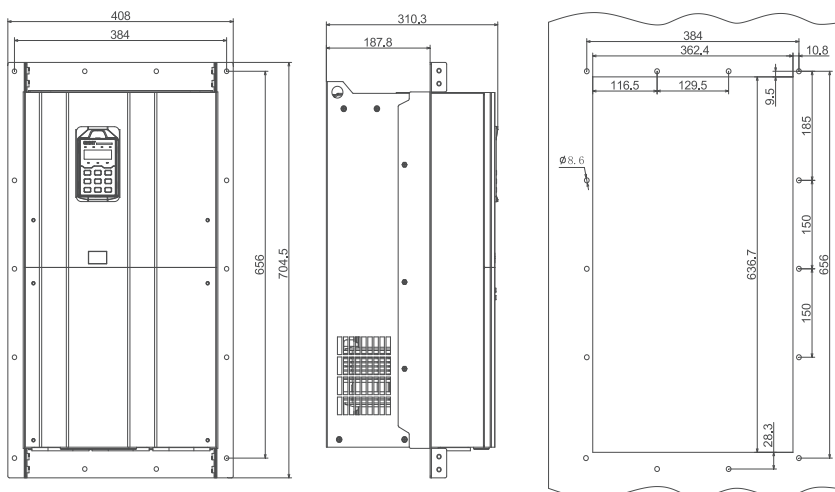

Figure 6.2.7 Schematic diagram of T8 flange kit

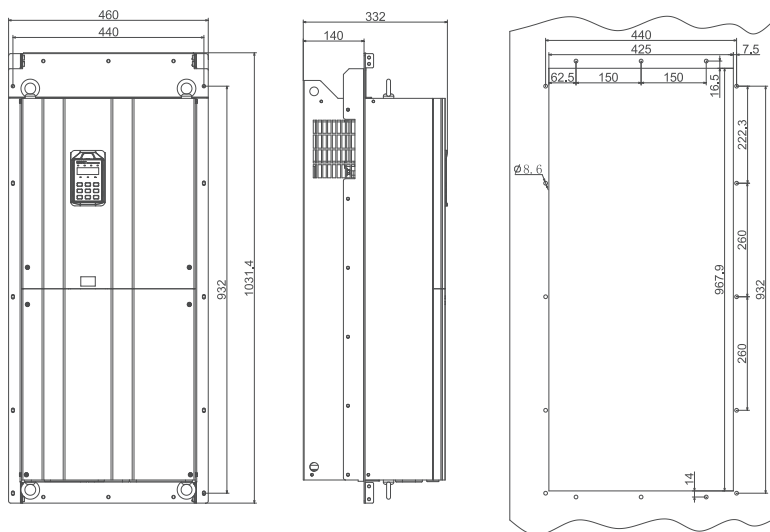

Figure 6.2.8 Schematic diagram of T9 flange kit

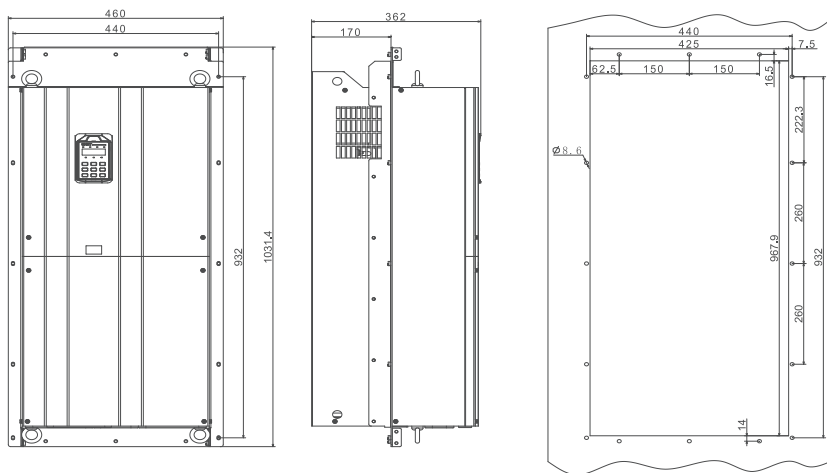

Figure 6.2.9 Schematic diagram of T10 flange kit

6.3 floor-mounted base installation

T11 and above models support the floor-mounted base installation method. For details, please consult our agent distributor or regional sales manager.

6.4 Outline and installation dimensions of operation panel and mounting bracket

NVF7 Series Drive comes standard with detachable LED operation panel. The operation panel supports two external installation methods: First, the installation method without mounting bracket; Second, the installation method with mounting bracket. The outline and installation dimensions of the operation panel and mounting bracket are shown below.

NVF7 series inverters are equipped with a removable LED display box as standard. The display box supports external mounting, and the shape and mounting dimensions of the display box and pallet are shown below.

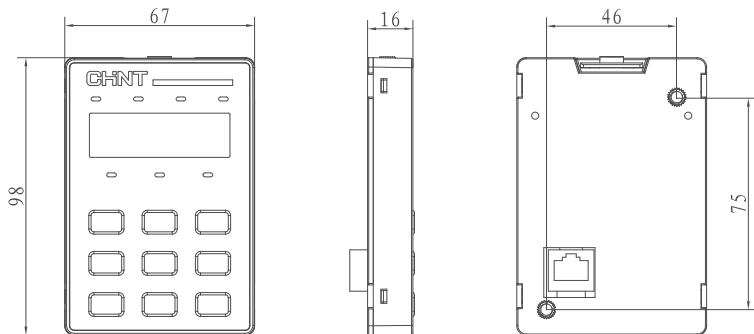
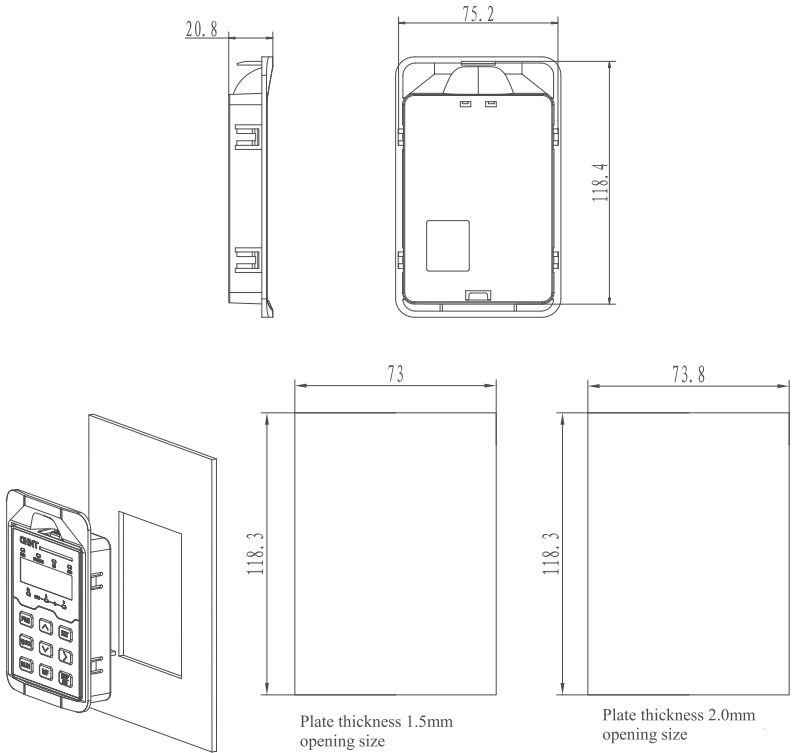

Figure 6.4.1 Overall Dimension of Operation panel



**Figure 6.4.2 Installation Dimension of Cabinet Door of Operation panel
(Installation with Mounting bracket)**

7 Installation, debugging and operation

7.1 Inspection before installation

◆ Installation environment

- 1) It shall be installed indoors or inside the cabinet
- 2) Power supply overvoltage level III
- 3) Ambient temperature and relative humidity

Constant torque drive: $-10^{\circ}\text{C} \sim +40^{\circ}\text{C}$, derated between $+40^{\circ}\text{C}$ and $+50^{\circ}\text{C}$, derated by 1% of rated power for every 1°C temperature rise.

The maximum relative humidity of air shall not exceed 90% ($+20^{\circ}\text{C}$) and 50% ($+40^{\circ}\text{C}$), and the change rate of relative humidity shall not exceed 5% per hour, and no condensation shall occur.

Dust-proof and waterproof grade Ip20

- 4) Environmental pollution below 2

- 5) Please install the drive in the following places:

In places where there is no oil mist, corrosive gas, flammable gas and dust, where there are no irritating substances and explosives, where there is little salt erosion, and where there is no direct sunlight, do not install the drive on flammable materials such as wood.

- 6) Altitude

When rated output, the altitude of the installation and use place shall not exceed 1000m.

It shall be derated in areas with an altitude of more than 1000 m, and it shall be derated at a rate of 10% for every 1000m altitude increase. The highest altitude of the installation and use site shall not exceed 3000m.

- 7) Vibration resistance

5~8.5Hz, displacement 3.5mm; 8.5~200Hz, acceleration is not greater than 5.9m/s².

7.2 Main circuit wiring mode

The schematic diagrams for wiring mode and main terminal of NVF7 Series Drive are shown below.

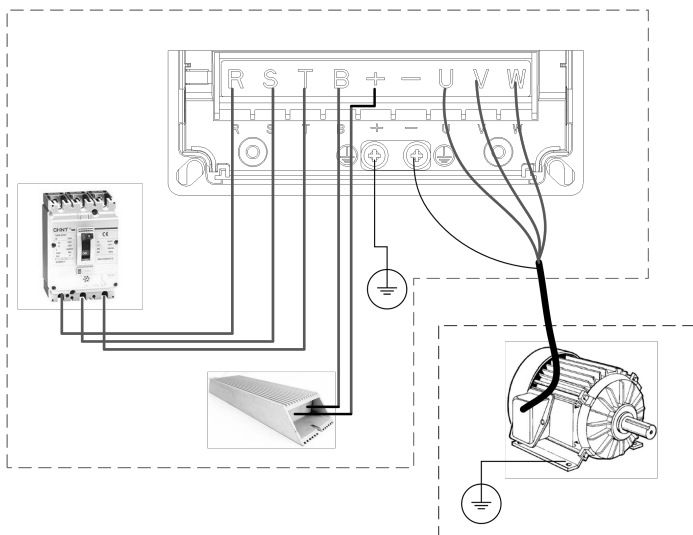

Figure 7.2.1 Schematic Diagram of Main Terminals of Each Shell Frame of the Product

◆ T2

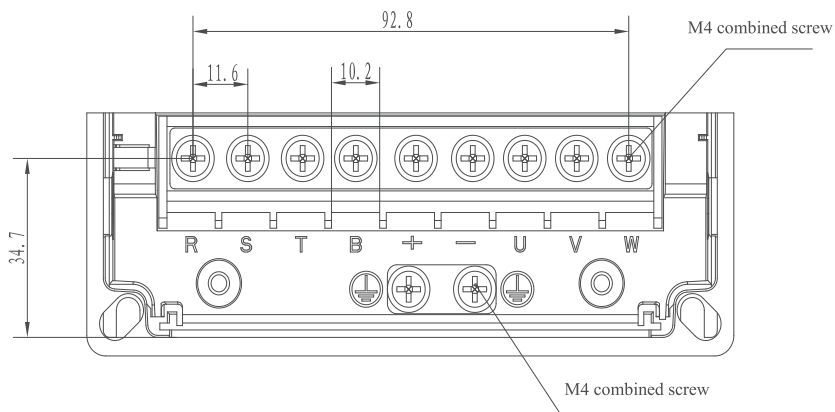
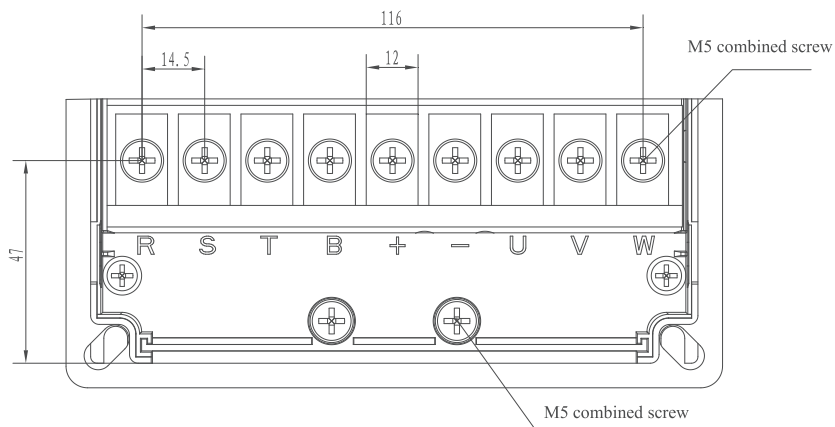

Figure 7.2.2 Schematic Diagram of Main Terminal of T2 Shell Frame

◆ T3



7.2.3 Schematic Diagram of Main Terminal of T3 Shell Frame

◆ T4

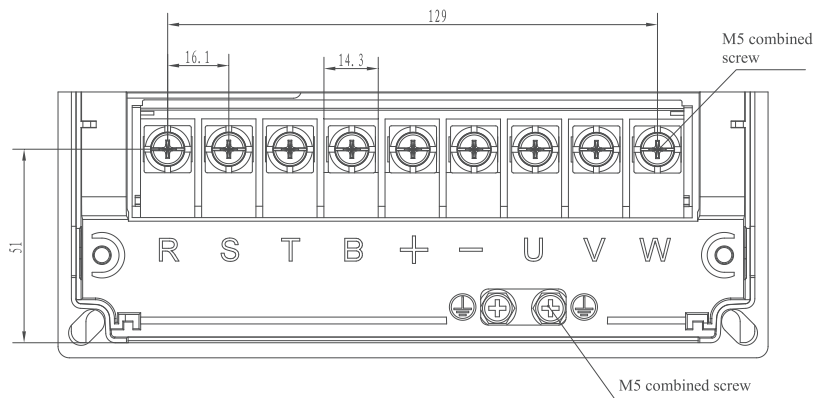

Figure 7.2.4 Schematic Diagram of Main Terminal of T4 Shell Frame

◆ T5

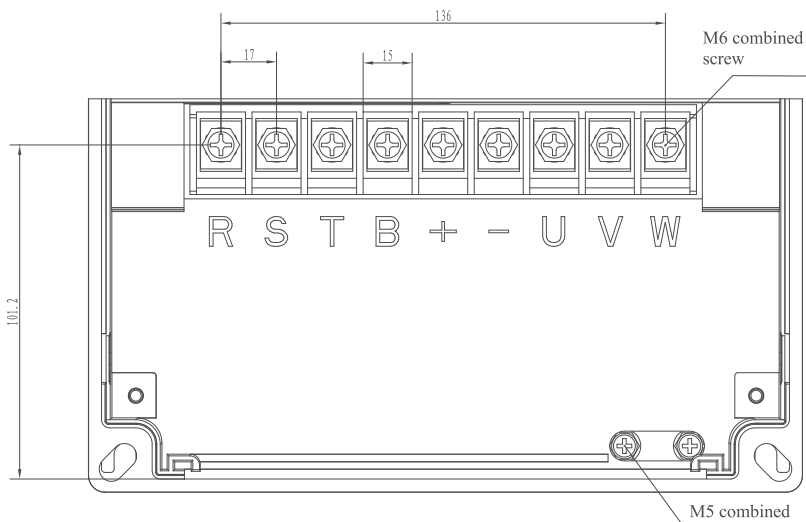

Figure 7.2.5 Schematic Diagram of Main Terminal of T5 Shell Frame

◆ T6

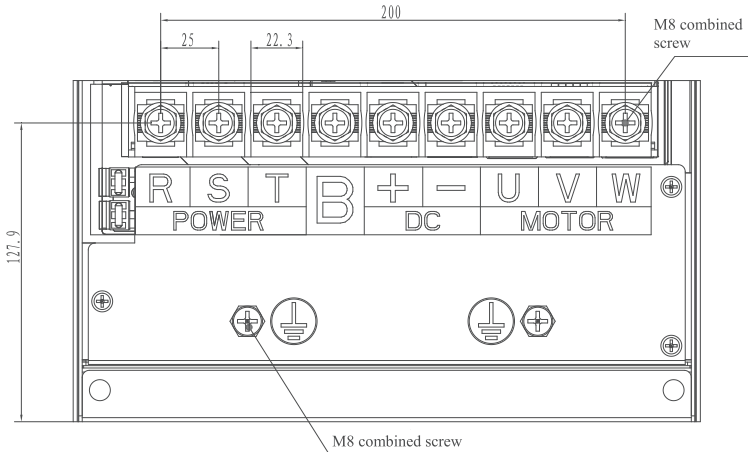

Figure 7.2.6 Schematic Diagram of Main Terminal of T6 Shell Frame

◆ T7

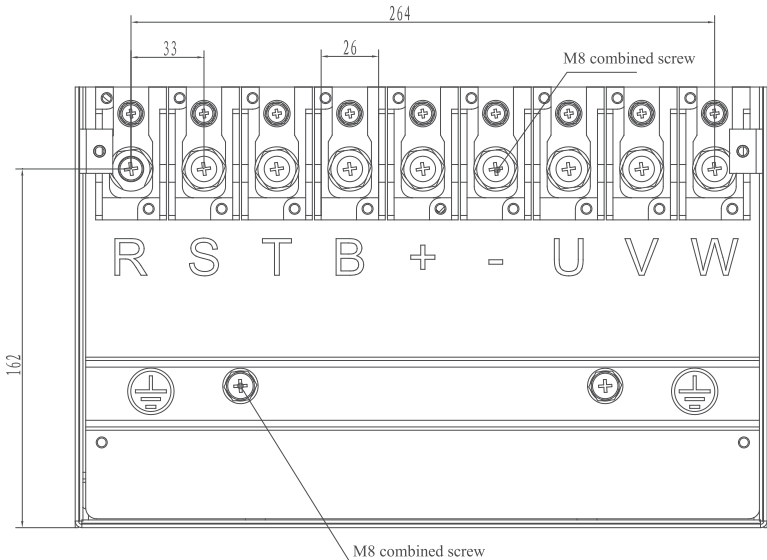

Figure 7.2.7 Schematic Diagram of Main Terminal of T7 Shell Frame

◆ T8

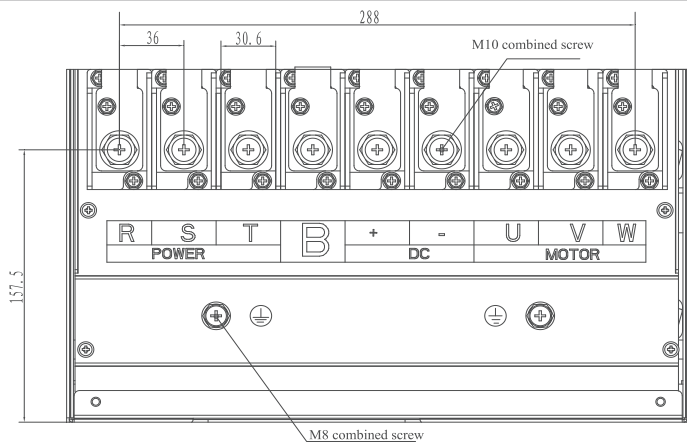

Figure 7.2.8 Schematic Diagram of Main Terminal of T8 Shell Frame

◆ T9~T10

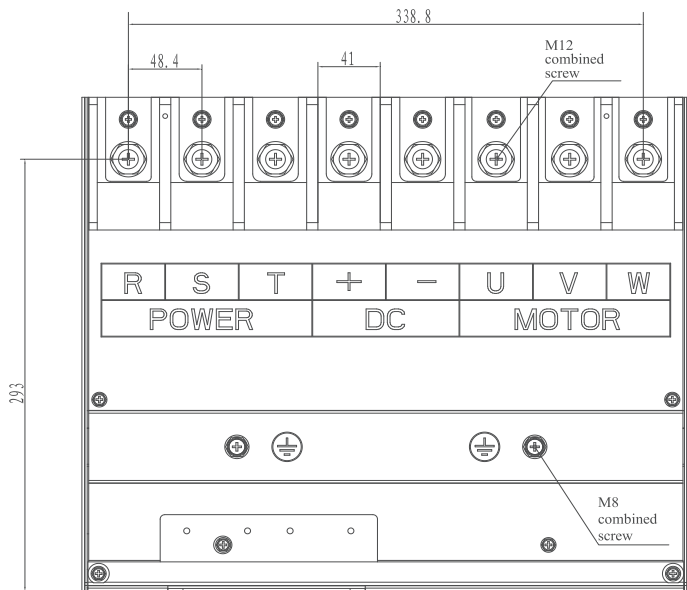
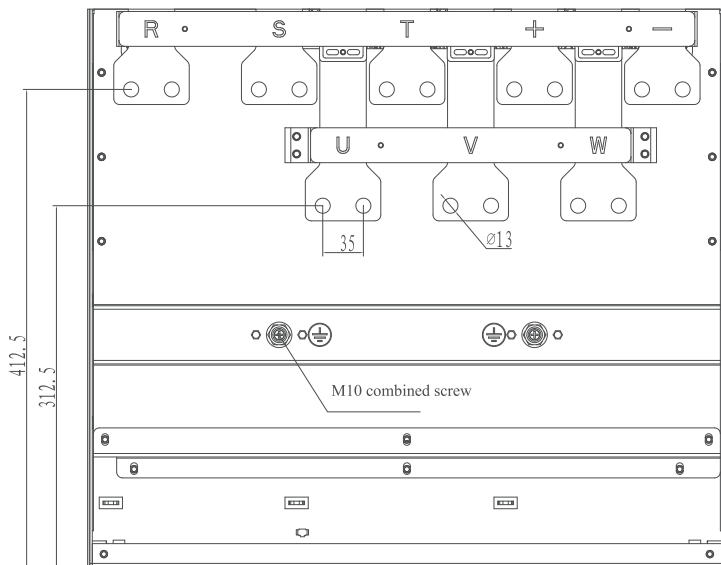

Figure 7.2.9 Schematic Diagram of Main Terminal of T9-T10 Shell Frame

♦ T11

Figure 7.2.10 Schematic Diagram of Main Terminal of T11 Shell Frame
Table 7.2.1 Description Table of Main Circuit Terminals

Terminal symbol	Terminal name	Function description	Wiring precautions
R,S,T	Main circuit power input	Three-phase AC voltage input end, connected with the power grid	1. Wiring must be conducted according to the terminal function, otherwise it may cause damage to the drive and even a fire; 2. The wiring length of the braking unit shall not exceed 10m, and twisted pair or tight double-wire parallel wiring shall be used; 3. When the external braking resistor is connected, it is not allowed to connect the braking resistor directly to the DC bus, otherwise it may cause damage to the drive and even a fire.
U,V,W	Drive output	Three-phase AC voltage output end, generally connected with motor	
	Grounding terminal	The safety protection grounding terminal must be reliably grounded, and the cross-sectional area of the grounding wire shall not be less than the cross-sectional area of the input power cord of the drive	
 	Positive and negative power terminals	Positive and negative power terminals of DC bus of drive	
B	Braking resistor connection terminal	Braking resistor connection terminal	

Table 7.2.2 Three-phase 380V main circuit terminal wiring and installation torque

Inverter Model	R, S, T, B, ⊕, ⊖, U, V, W, ⊕					
	Terminal Screws	Tightening torque (N·m)	Recommended Cable Size (mm ²)	grounding screw	Tightening torque (N·m)	Recommended Cable Size (mm ²)
NVF7-0.4T/0.75P-S4-B(1)	M4	1.2~1.5	1	M4	1.2~1.5	1
NVF7-0.75T/1.1P-S4-B(1)	M4	1.2~1.5	1	M4	1.2~1.5	1
NVF7-1.1T/1.5P-S4-B(1)	M4	1.2~1.5	2.5	M4	1.2~1.5	2.5
NVF71.5T/2.2P-S4-B(1)	M4	1.2~1.5	2.5	M4	1.2~1.5	2.5
NVF7-2.2T/3.0P-S4-B(1)	M4	1.2~1.5	2.5	M4	1.2~1.5	2.5
NVF7-3.0T/4.0P-S4-B(1)	M4	1.2~1.5	4	M4	1.2~1.5	4
NVF7-4.0T/5.5P-S4-B(1)	M4	1.2~1.5	4	M4	1.2~1.5	4
NVF7-5.5T/7.5P-S4-B(1)	M4	1.2~1.5	6	M4	1.2~1.5	6
NVF7-7.5T/11P-S4-B(1)	M5	2.5~3.0	6	M5	2.5~3.0	6
NVF7-11T/15P-S4-B(1)	M5	2.5~3.0	6	M5	2.5~3.0	6
NVF7-15T/18.5P-S4-B(1)	M5	2.5~3.0	10	M5	2.5~3.0	10
NVF7-18.5T/22P-S4-B(1)	M6	4.0~6.0	16	M5	2.5~3.0	16
NVF7-22T/30P-S4-B(1)	M6	4.0~6.0	16	M5	2.5~3.0	16
NVF7-30T/37P-S4-B(1)	M8	9.0~10.0	25	M8	9.0~10.0	16
NVF7-37T/45P-S4-B(1)	M8	9.0~10.0	25	M8	9.0~10.0	16
NVF7-45T/55P-S4-B(1)	M8	9.0~10.0	35	M8	9.0~10.0	16
NVF7-55T/75P-S4-B(1)	M8	9.0~10.0	50	M8	9.0~10.0	25
NVF7-75T/90P-S4-B(1)	M10	17.6~22.5	70	M8	9.0~10.0	35
NVF7-90T/110P-S4-B(1)	M10	17.6~22.5	95	M8	9.0~10.0	50
NVF7-110T/132P-S4-B(1)	M10	17.6~22.5	120	M8	9.0~10.0	70
NVF7-132T/160P-S4-B(1)	M12	31.4~39.5	150	M8	9.0~10.0	70
NVF7-160T/185P-S4-B(1)	M12	31.4~39.5	185	M8	9.0~10.0	95
NVF7-185T/200P-S4-B(1)	M12	31.4~39.5	185	M8	9.0~10.0	95
NVF7-200T/220P-S4-B(1)	M12	31.4~39.5	95X2	M8	9.0~10.0	95
NVF7-220T/250P-S4-B(1)	Terminals are nutted, wrench or socket recommended		120X2	M10	17.6~22.5	120
NVF7-250T/280P-S4-B(1)			150X2	M10	17.6~22.5	150
NVF7-280T/315P-S4-B(1)			185X2	M10	17.6~22.5	185

Table 7.2.3 Three-phase 230V main circuit terminal wiring and installation torque

Inverter Model	R, S, T, B, ⊕, ⊖, U, V, W, ⊕					
	Terminal Screws	Tightening torque (N·m)	Recommended Cable Size (mm ²)	grounding screw	Tightening torque (N·m)	Recommended Cable Size (mm ²)
NVF7-0.4T/0.75P-S2-B	M4	1.2~1.5	2.5	M4	1.2~1.5	2.5
NVF7-0.75T/1.1P-S2-B	M4	1.2~1.5	2.5	M4	1.2~1.5	2.5
NVF7-1.1T/1.5P-S2-B	M4	1.2~1.5	2.5	M4	1.2~1.5	2.5
NVF7-1.5T/2.2P-S2-B	M4	1.2~1.5	4	M4	1.2~1.5	4
NVF7-2.2T/3.0P-S2-B	M4	1.2~1.5	4	M4	1.2~1.5	4
NVF7-3.0T/4.0P-S2-B	M4	1.2~1.5	6	M4	1.2~1.5	6
NVF7-4.0T/5.5P-S2-B	M5	2.5~3.0	6	M5	2.5~3.0	6
NVF7-5.5T/7.5P-S2-B	M5	2.5~3.0	6	M5	2.5~3.0	6
NVF7-7.5T/9.5P-S2-B	M5	2.5~3.0	10	M5	2.5~3.0	10
NVF7-9.5T/11P-S2-B	M6	4.0~6.0	16	M5	2.5~3.0	16
NVF7-11T/15P-S2	M6	4.0~6.0	16	M5	2.5~3.0	16
NVF7-15T/18.5P-S2	M8	9.0~10.0	25	M8	9.0~10.0	16
NVF7-18.5T/22P-S2	M8	9.0~10.0	25	M8	9.0~10.0	16
NVF7-22T/30P-S2	M8	9.0~10.0	35	M8	9.0~10.0	16
NVF7-30T/37P-S2	M8	9.0~10.0	50	M8	9.0~10.0	25
NVF7-37T/45P-S2	M10	17.6~22.5	70	M8	9.0~10.0	35
NVF7-45T/55P-S2	M10	17.6~22.5	95	M8	9.0~10.0	50

Table 7.2.4 Single-phase 230V main circuit terminal wiring and installation torque

Inverter Model	R, S, T, B, ⊕, ⊖, U, V, W, ⊕					
	Terminal Screws	Tightening torque (N·m)	Recommended Cable Size (mm ²)	grounding screw	Tightening torque (N·m)	Recommended Cable Size (mm ²)
NVF7-0.4T-D2-B	M4	1.2~1.5	2.5	M4	1.2~1.5	2.5
NVF7-0.75T-D2-B	M4	1.2~1.5	2.5	M4	1.2~1.5	2.5
NVF7-1.5T-D2-B	M4	1.2~1.5	4	M4	1.2~1.5	4
NVF7-2.2T-D2-B	M4	1.2~1.5	4	M4	1.2~1.5	4
NVF7-3.0T-D2-B	M4	1.2~1.5	6	M4	1.2~1.5	6
NVF7-4.0T-D2-B	M5	2.5~3.0	6	M5	2.5~3.0	6

7.3 Wiring method of control circuit

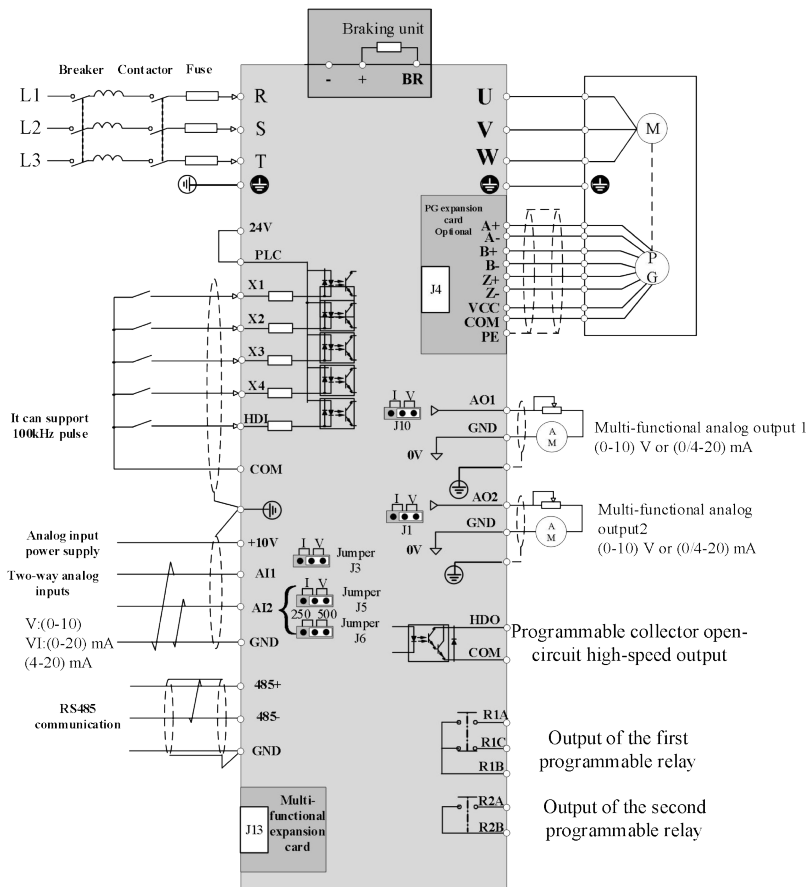
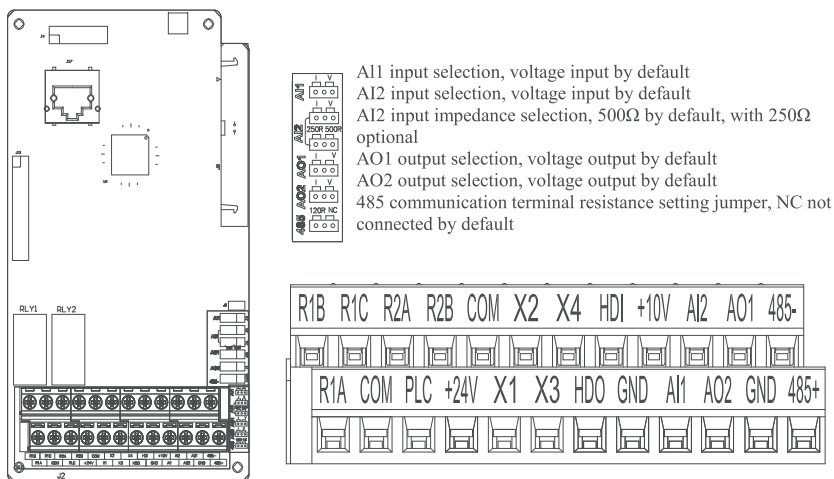

Figure 7.3.1 Control Terminal and Wiring Schematic Diagram

Figure 7.3.2 Layout of Control Circuit Terminals
Table 7.3.1 Control Terminal Function

Type	Terminal	Name	Description of terminal functions
Power supply	+10V	+10V power supply	External power supply of +10V, maximum output current: 10mA It is generally used as the working power supply of an external potentiometer. The resistance range of the potentiometer is: 1kΩ~5kΩ
	GND	+10V power ground	
	+24V	+24V power supply	External power supply of +24V, which is generally used as working power supply for digital input and output terminals and external sensor power supply Maximum output current: 200mA
	COM	+24V power supply common terminal	
Analog input	PLC	External power input terminal	By default, it is connected with +24V by short contact tag When using external power supply to drive X1~X4 and HDI, PLC shall be connected with external power supply and disconnected from +24V power supply terminal
	AI1	Analog single-ended input AI1	Voltage input range: 0Vdc~10Vdc, Current input range: 0mA~20mA or 4mA~20mA Decided by jumper J3 selection Input impedance: 22kΩ for voltage input and 500Ω for current input.
	AI2	Analog single-ended input AI2	Voltage input range: 0Vdc~10Vdc, Current input range: 0mA~20mA or 4mA~20mA Decided by jumper J5 selection Input impedance: 22kΩ for voltage input and 500Ω or 250Ω for current input through J6 jumper

Type	Terminal	Name	Description of terminal functions	
Analog output	AO1	Analog output	The voltage or current output is determined by the selection of J10 and J1 jumpers on the control panel respectively Output voltage range: 0V~10V Output current range: 0mA~20mA or 4mA~20mA	
	AO2	Analog output		
Communication	485+	RS485 communication interface	Positive terminal of 485 differential signal	Standard RS485 communication interface Please use twisted pair or shielded wire
	485-		Negative terminal of 485 differential signal	
Digital input terminal	X1	Multifunctional input terminal 1	Optical coupling isolation, compatible with bipolar input Input impedance: 1.39kΩ Voltage range at effective level input: 18V~30V Programmable switch input terminals with multiple functions, see function codes F5-00 ~ F5-03	
	X2	Multifunctional input terminal 2		
	X3	Multifunctional input terminal 3		
	X4	Multifunctional input terminal 4		
	HDI	High-speed input terminal HDI	Besides the characteristics of X1~X4, it can also be used as a high-speed pulse input channel Maximum input frequency: 100kHz Input impedance: 1.03kΩ	
Digital output terminal	HDO	High speed pulse output terminal	Constrained by the parameter F6-00HDO terminal output mode selection When it is output as a high-speed pulse, the highest frequency is 100kHz (set by F6-09) When it is used as open-collector output, the output terminals of pulse signals with various functions can be programmed. See function code F6-01	
Relay output terminal 1	R1B-R1A	Normally open terminal contact	For the output terminal of programmable multi-function relay, see function code F6-02 Contact drive capability: 5A 250V (AC) 30Vdc, 1A	
	R1B-R1C	Normally closed terminal contact		
Relay output terminal 2	R2B-R2A	Normally open terminal contact	For the output terminal of programmable multi-function relay, see function code F6-04 Contact drive capability: 5A 250V (AC) 30Vdc, 1A	

7.4 Wiring method

7.4.1 Power grid wiring

This product is suitable for the power grid system with neutral grounding. If it is used in the IT power grid system, the internal filter element needs to be disconnected, and the external filter cannot be connected, otherwise it will cause damage to the drive or personal injury. As shown in the figure below. It is necessary to remove the ground jumper of the varistor (TVD) and the ground jumper of the safety capacitor (EMC), such as the terminals No.1 and No.2 shown in the figure below, and the filter cannot be installed, otherwise it may cause injury or drive failure. When the earth leakage circuit breaker is configured, if there is a phenomenon of tripping and leakage protection during starting, the safety capacitor (EMC) jumper to the ground can be removed, as the No.2 terminal shown in the figure below(models of 3KW and below can be disconnected from the ground through the screw in the figure on the left).

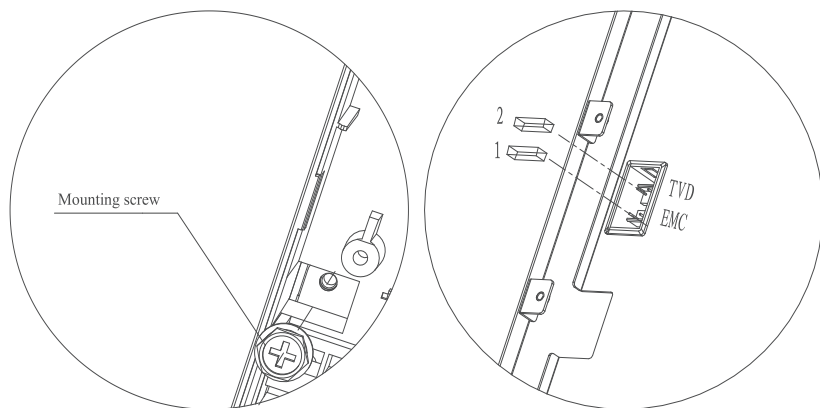

Figure 7.4.1 Schematic Diagram of the Position of Varistor (TVD) and Safety Capacitor (EMC) Jumper to Ground

Note:

IT system is a system in which the neutral point of power supply is not grounded and the exposed conductive part of electrical equipment is directly grounded. IT system can have neutral wire, but IEC strongly recommends not to set neutral wire. Because if a neutral wire is set and a grounding fault occurs at any point of the N wire in the IT system, the system will no longer be an IT system.

When the first grounding fault occurs in the IT system, it is only the non-fault capacitance current relative to the ground, and its value is very small. If the voltage of the exposed conductive part to the ground does not exceed 50V, it is not necessary to cut off the fault circuit immediately to ensure the continuity of power supply; Place of usage: It requires high continuity of power supply, such as emergency power supply, large hospital operating room, electric steelmaking, underground mine and other places.

7.4.2 Analog input terminal

Because weak analog voltage signals are particularly vulnerable to external interference, it is generally necessary to use shielded cables, and the wiring distance shall be as short as possible, not exceeding 20m. In some situations where analog signals are seriously disturbed, filter capacitors or ferrite cores shall be added to the analog signal source side.

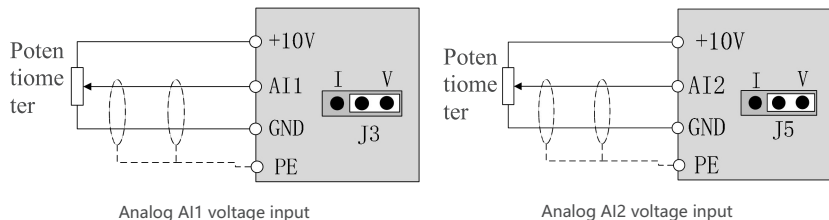
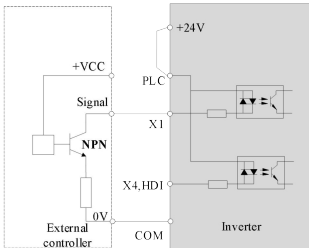

Figure 7.4.2 Wiring Diagram of Analog Voltage Input Terminal

7.4.3 Digital input terminal

• Sink wiring



Sink wiring using internal 24V power supply of inverter

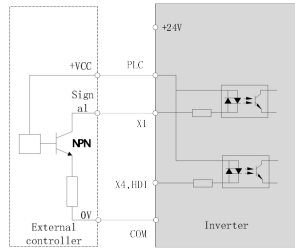

Sink wiring using external 24V power supply of inverter

Figure 7.4.3 Sink Wiring

Using the internal 24V power supply of the drive is one of the most commonly used wiring methods. The PLC of the drive is short-circuited with the +24V terminal, and the COM terminal of the drive is connected with 0V of the external controller.

If an external 24V power supply is used, the short contact tag between +24V and PLC must be removed, the +24V positive pole of the external power supply shall be connected to the PLC terminal, and the 0V external power supply shall be connected to the corresponding X terminal through the controller control contact.

• Source wiring

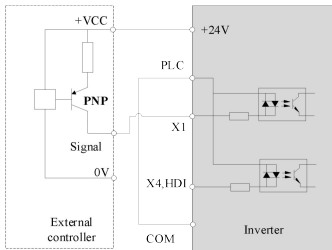

Source wiring using internal 24V power supply of inverter

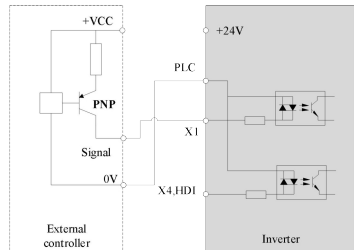

Source wiring using external 24V power supply of inverter

Figure 7.4.4 Source Wiring

If the internal 24V power supply of drive is used, the short contact tag between +24V and PLC must be removed, PLC and COM shall be connected together, and +24V shall be connected with the common terminal of external controller.

If an external power supply is used, the short contact tag between +24V and PLC must be removed, and the PLC shall be connected with 0V of the external power supply. The 24V positive pole of the external power supply shall be connected to the corresponding terminal X through the external controller control contact.

• HDI wiring mode of high-speed input terminal

When HDI is used as a high-speed pulse input, the maximum allowable frequency is 100kHz.

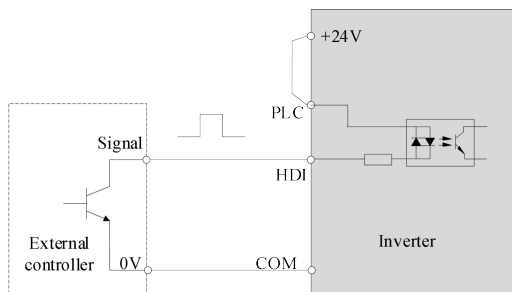

Figure 7.4.5 High-speed Pulse Input

7.4.4 Digital output terminal

When the digital output terminal needs to drive the relay, absorption diodes shall be installed on both sides of the relay coil. 24V power supply damage. The driving capacity is no more than 50mA.

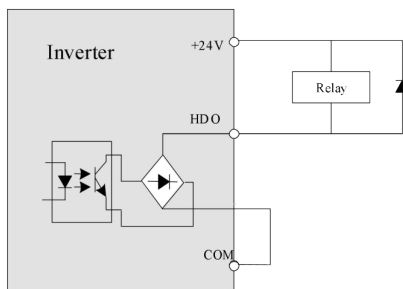
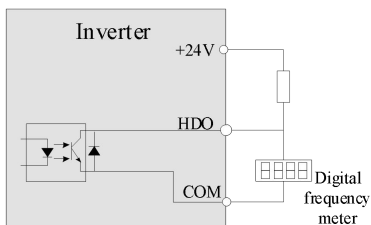
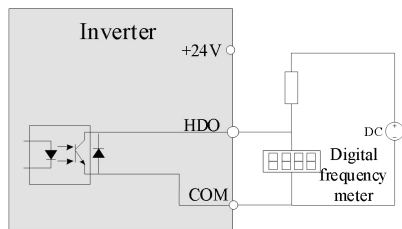

Figure 7.4.6 Schematic Diagram of Digital Output Terminal Wiring

When HDO terminal is continuous pulse output, the maximum output frequency is 100kHz.



Use the internal 24V power supply of the inverter



Use external 24V power supply of inverter

Figure 7.4.7 Wiring Diagram of High-speed Digital Output Terminal

7.5 First start-up step

The following describes the basic setting steps required for the initial start of the drive.

- ◆ Process 1: Basic debugging process

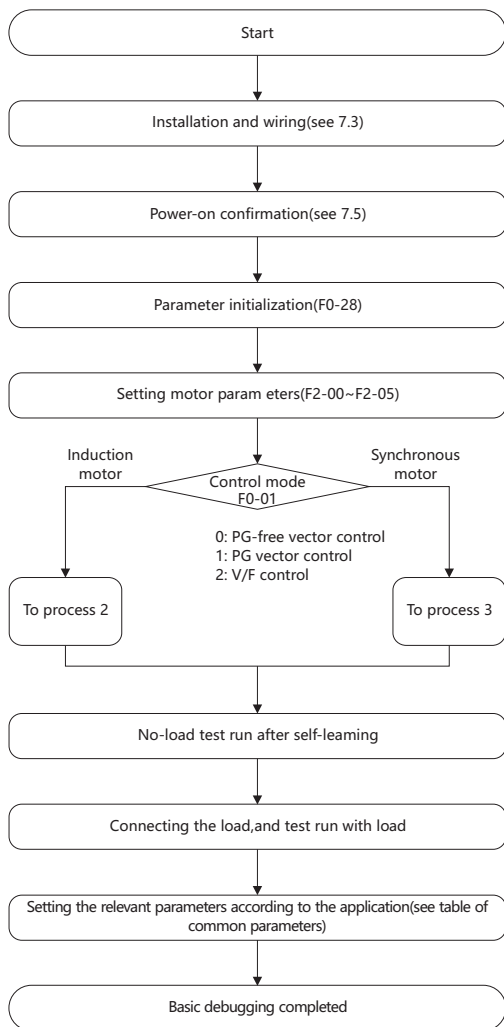

Figure 7.5.1 Basic Debugging Flowchart

Common Parameter List				
Parameters	Name	Setting range	Factory value	Change
F0-02	Run instruction selection	0: Operation panel 1: Terminal 2: Communication	0	○
F0-03	Main frequency instruction input selection	0: Digital setting (without power-off memory) 1: Digital setting (with power-off memory) 2: AI1 3: AI2 4: AI3 5: Pulse setting (HDI) 6: Multi-segment instruction 7: Simple PLC 8: PID 9: Communication setting	0	●
F0-08	Preset frequency	0.00Hz ~ maximum frequency (F0-10)	50.00Hz	○
F0-09	Direction of operation	0: Run in the default direction 1: Run in the opposite direction to the default direction	0	○
F0-17	Acceleration time 1	0.00s~650.00s(F0-19=2) 0.0s~6500.0s(F0-19=1) 0s~65000s(F0-19=0)	Model determination	○
F0-18	Deceleration time 1	0.00s~650.00s(F0-19=2) 0.0s~6500.0s(F0-19=1) 0s~65000s(F0-19=0)	Model determination	○
F0-28	Parameter initialization	0: No operation 01: Clear record information 02: Restore factory parameters, excluding motor parameters 04: Back up user's current parameters 05: Restore user backup parameters	0	●
F1-00	Startup mode	0: Direct startup 1: Speed tracking and restart 2: Pre-excitation start (AC asynchronous machine) 3: SVC quick start	0	○
F1-03	Starting frequency	0.00Hz~50.00Hz	0.00Hz	○
F1-04	Holding time of starting frequency	0.0s~100.0s	0.0s	●

◆ Process 2: Self-learning process of induction motor

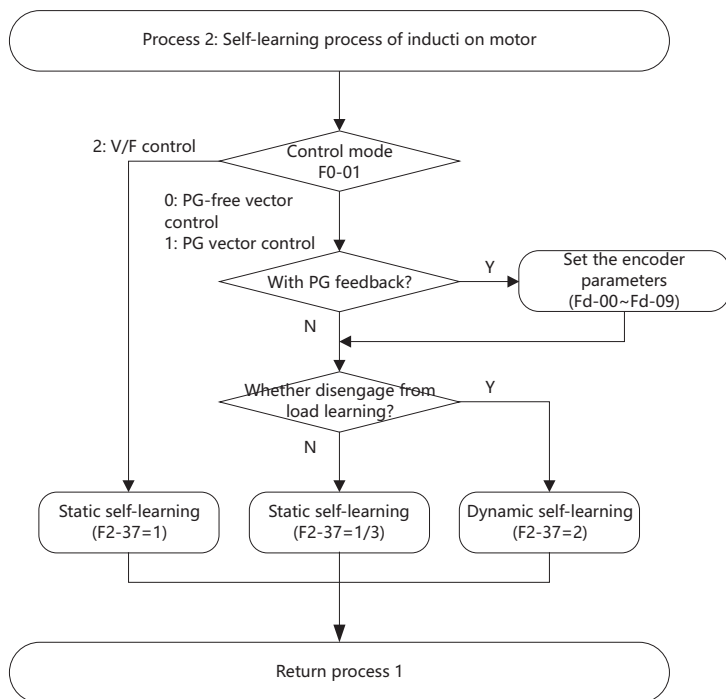

Figure 7.5.2 Self-learning of Induction Motor

7.6 Confirmation items of drive at initial startup

Please confirm the items in Table 7.6.1 before the drive is powered on.

Table 7.6.1 Confirmation Items of Drive at Initial Startup

Phase	Items	Content
Before power-on	Input power voltage	Please confirm whether the input power specification is consistent with the product specification 220V grade: 380V grade:
	Main circuit input power supply wiring	Please confirm that the input power supply is correctly connected to the terminal R/S/T S/T
	Main circuit output and motor wires	Please confirm that the output terminal U/V/W and the motor terminal U/V/W are connected correctly, and the screws are fastened according to the torque requirements
	Braking resistor/Braking resistor wiring	Please confirm whether the product model has braking function Please make sure that the braking resistor is correctly connected to the "+" terminal and the "B terminal" Please make sure that the external braking unit is properly connected to the "+" and "-" terminals
	Grounding	Please confirm that the drive and motor are properly grounded, the grounding wire meets the requirements and the screws are fastened according to the torque requirements
	Control circuit wiring	Please confirm that the control circuit is correctly wired and the control terminal screws are fastened according to the torque requirements.
	Motor and mechanical load connection	Before the first operation, please ensure that the motor shaft and the mechanical load remain separated, and then connect the mechanical load after the motor runs properly without load Please confirm the distance between the drive and the motor and the cable length
After power-on	Operation panel state	The drive is in standby state and in trouble-free state (Figure)
	DC bus voltage	Press the ">" key to switch, and confirm that the bus voltage meets the requirements The DC bus voltage VDC is about 1.4 times of the AC input voltage V_{in}
First debugging preparation	Debug according to specifications	See Chapter 7.4

7.7 Usage of operation panel

7.7.1 LED operation panel

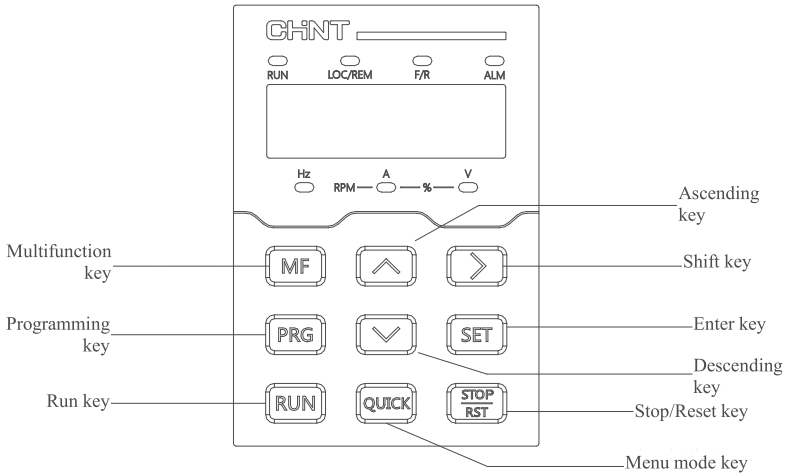

Figure 7.7.1 Operation Panel Diagram

◆ Description of indicators:







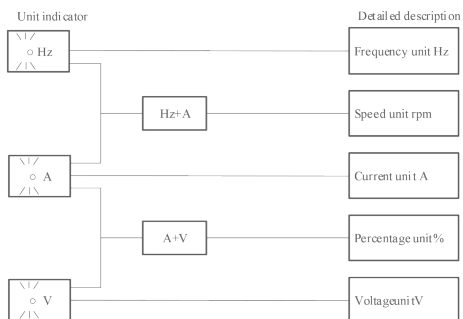

The indicators are divided into state indicators and unit indicators. The state indicator are described as follows:

Indicator	Display state	Display description
RUN (run instruction)	On	Running state
	Off	Stop state
LOC/REM (control mode indication)	Off	Panel control
	On	Terminal control
	Flash	Communication control
F/R (direction indication)	On	Reverse running
	Off	Forward running
ALM (fault indication)	On	In torque control
	Slow flash	Motor parameter tuning
	Fast flash	Drive fault

The unit indicator is specified as follows:

Figure 7.2 Schematic Diagram of Unit Indicator

Description of key functions:

Key	Function	Description
	Programming key	Enter the primary interface/Return to the previous interface
	Enter key	Enter key (to confirm data or operation/enter the next menu)
	Ascending key	Ascending key (to change group number, index number and parameter value)
	Descending key	Descending key (to change group number, index number and parameter value)
	Shift key	When setting parameters, move and select the position to be modified
	Run key	Start-stop control of drive
	Stop/Reset key	In running state, it is used for stop operation; In fault state, it is used for reset operation
	Multifunction key	Execute the action according to the setting function of parameter F7-02
	Menu mode key	Multiple menu mode switching

◆ Parameter mode operation

This series drive provides three modes for finding function codes:

- (1) display all function code parameters of the drive
- (2) Users can select and customize the commonly used function codes, up to 32 of which can be customized to form a user-defined function code set; The user determines the functional parameters to be displayed through the FF group

(3) Drive automatically searches to find out the function code different from the factory value for users to choose quickly;

The display modes of the three function codes are switched by <Menu Mode> on the panel. When switching to the selected mode, press <Enter Key> to select it, and when entering the menu to view the parameters, the parameters will be displayed in the selected mode. Various modes are displayed as follows:

Parameter display	Display
All functional parameters	-ALL-
User-defined parameters	--U--
User-changed parameters	--C--

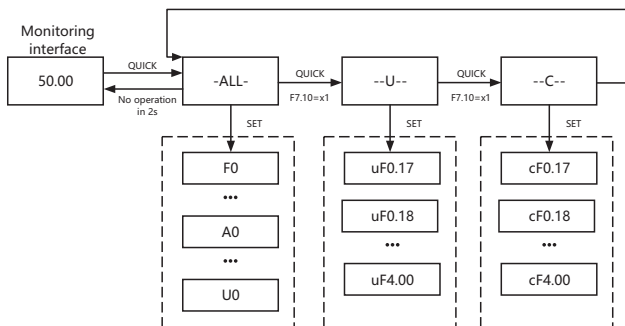

Figure 7.7.3 Selection of Menu Mode Operation

◆ Parameter setting

The operation panel of the drive adopts three-level menu structure for parameter setting and other operations. Three-level menus are: Functional parameter group (level I menu) → Function code (level II menu) → Function code set value (level III menu). The operation flow is as follows:

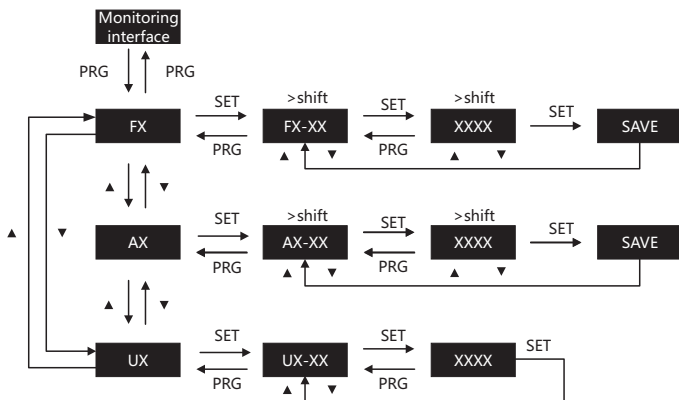

Figure 7.7.4 Parameter Setting Operation

Press PRG key or SET key to return to level II menu when operating in the level III menu. The difference is as follows: press SET to save the set parameters, then return to level II menu and automatically transfer to the next function code; press PRG to abandon the current parameter modification and directly return to the level II menu of the current function code number.

In the Level III menu state, if the parameter does not flash, it means that the function code cannot be modified. The possible reasons are as follows:



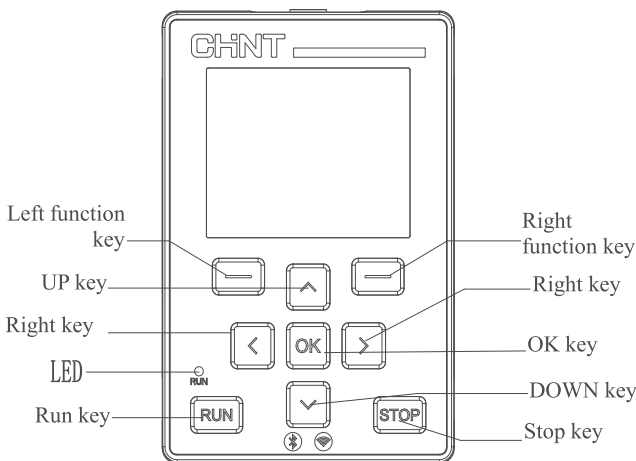

- 1) This function codes are non-modifiable parameters, such as drive type, actual detection parameters, operation record parameters, etc.
- 2) This function code cannot be modified in the running state, and can only be modified after stopping the machine.
- 3) The parameters are protected. F7-11 is set to 1 (all function codes cannot be modified)

7.7.2 LCD operation panel



• Operation panel functions:

Key	Name	Function
	Left function key	Back key, used to return to the interface
	Right function key	OK key, used to enter the interface
	UP key	It is used for up and down selection and data modification
	DOWN key	It is used for up and down selection and data modification

Key	Name	Function
	Right key	It is used for scrolling display and data modification of each interface
	Right key	It is used for scrolling display and data modification of each interface
	OK key	Save key after modifying parameters in parameter interface
	Run key	Start key of drive
	Stop key	Stop key of drive

- Panel LCD indicator description:

LCD indicator color	Indication state
Off	Standby state
Green	Running state
Red light flashing	Fault state

7.8 Motor self-learning

Please select the most suitable self-learning mode according to the type of motor used, the control mode of drive and the installation environment of motor.

Warning! When dynamic self-learning is selected, the motor will rotate at a speed of more than 50% of the rated frequency. Please make sure the surrounding area is safe.

- ◆ Self-learning of induction motor

Please input the motor parameters according to the motor nameplate before self-learning:

Self-learning related parameters of induction motor				
F2-00	Motor type selection	0: Normal asynchronous motor 1: Frequency conversion asynchronous motor	0	◦
F2-01	Rated power of motor	0.1kW~1000.0kW	Model determination	◦
F2-02	Rated voltage of motor	1V~2000V	Model determination	◦
F2-03	Rated current of motor	0.01A~655.35A (drive power ≤ 55kW) 0.1A~6553.5A (drive power >55kW)	Model determination	◦
F2-04	Rated frequency of motor	0.01Hz~maximum frequency	Model determination	◦
F2-05	Rated speed of motor	1rpm~65535rpm	Model determination	◦
Fd-00	Number of encoder lines	1~65535	1024	◦
Fd-01	Encoder type	0: ABZ incremental encoder 2: Resolver	0	◦

Self-learning related parameters of induction motor

Fd-03	ABZ incremental encoder AB phase sequence	0: Forward 1: Reverse	0	⊙
Fd-07	Pole pairs of resolver	1~65535	1	⊙

Where Fd-00, Fd-01, Fd-03 and Fd-07 are the parameters that need to be set in the control with PG feedback.

Selection of self-learning mode for induction motor:

Method	Parameters	Use conditions	Tuning effect
Dynamic self-learning	F2-37 = 2	<ul style="list-style-type: none"> When the motor can be separated from the mechanical load and the motor is running properly during self-learning When running the motor with constant output characteristics When high-precision control is required When the motor cannot be separated from the mechanical load, but the load of the motor is less than 30% 	Optimal
Partial static self-learning	F2-37 = 1	<ul style="list-style-type: none"> When the wiring distance under V/f control is above 50 m, When the motor output and drive capacity are different 	General
Complete static self-learning	F2-37 = 3	<ul style="list-style-type: none"> When the motor cannot be separated from the mechanical load, and the load of the motor is more than 30% 	Good

◆ Self-learning step

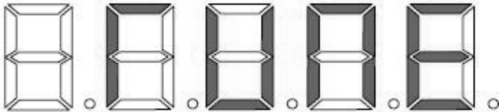
Steps	Process
Step 1	The run instruction of drive is selected as panel operation (F0-02 = 0)
Step 2	Accurately input the motor nameplate parameters (F2-00 ~ F2-05)
Step 3	Accurately input the encoder parameters (Fd-00, Fd-01, Fd-03, Fd-07), which is required for control with PG
Step 4	<p>Set the motor tuning mode (F2-37), press the SET key, and the keyboard will display it</p> 
Step 5	<p>Press the RUN key on the operation panel, the drive will drive the motor to run, and the running indicator will light up, and the ALM indicator will flash slowly. When the tuning lasts for a period of time, the indicator will go out, the code displayed on the panel will disappear, and it will return to the normal parameter display interface, indicating that the tuning is completed. The drive will automatically obtain the motor parameters according to the selected tuning mode.</p> <p>Induction motor: Static part parameter tuning: obtain F2-06 ~ F2-08 parameters Static complete parameter tuning: obtain F2-06 ~ F2-10 parameters Dynamic complete parameter tuning: obtain F2-06 ~ F2-10 and Fd-03 parameters</p> <p>Synchronous motor: Static parameter tuning: obtain F2-16~F2-18 parameters Dynamic parameter tuning: obtain F2-16~F2-18 and F2-20 parameters</p>

7.9 Test run

Set the basic parameters, and start the test run after self-learning of the motor.

Warning! Safety measures when restarting the machine: After the wiring operation and parameter setting are completed, please be sure to perform test run, and make sure that the machine can operate safely. If the system is used directly without test run, it may cause death or serious injury.

7.9.1 Test run under no-load state

Please confirm the running state of the motor before connecting it with the machine.

Precautions before operation:

Before running the motor, please confirm the following items:

- Please confirm the safety around the motor and machine.
- Please confirm whether the emergency stop circuit and the safety device on the machine side operate correctly.

Confirmation items during running:

Confirm the following items during running:

- Whether the motor is forward running.
- Whether the motor rotates smoothly (whether there is abnormal sound and vibration).
- Whether the acceleration and deceleration of the motor are smooth.

7.9.2 No-load run

No-load test run steps are as follows.

- 1) Set F0-08 to 5.00Hz (target operating frequency).
- 2) Press RUN. The running indicator is on, and the motor rotates forward at 5.00Hz.
- 3) Make sure that the motor rotates in the correct direction, and the drive shows no fault. When a fault is displayed, troubleshoot it.

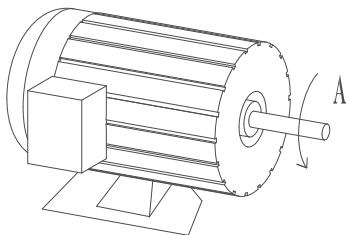

Forward running direction of the motor: (counterclockwise as viewed from the load shaft)

- 4) Increase the set value of F0-08 to improve the motor operating frequency. When increasing the operating frequency, please confirm the responsiveness and adjust the set value by 10Hz.
- 5) Press > shift key, the panel indicator A will light up, and the panel will display the current output current. If the output current of the drive does not exceed the rated current of the motor, it is in normal state.
- 6) After confirming that the motor can run properly, press STOP. When the motor stops, the RUN indicator goes out.

7.9.3 Actual load test run

After confirming the running in no-load state, connect the motor with the mechanical system for test run.

Precautions before operation:

Before running the motor, please confirm the following items:

- Please confirm the safety of the motor and its surroundings.
- Please confirm whether the emergency stop circuit and the safety device on the machine side operate correctly.
- Please make sure that the motor stops completely.

- Please connect the motor and the machine.

Please confirm whether the mounting screws are loose and fix the motor shaft and mechanical system. Please be prepared to press the STOP key at any time in case of abnormal action.

Confirmation items during running:

- Whether the machine moves in the right direction (whether the motor rotates in the right direction).
- Whether the acceleration and deceleration of the motor are smooth.

7.9.4 On-load test run

After the motor is connected to the machine, please implement test run according to the same operation steps as no-load operation.

- Please confirm whether the output current displayed on the panel is too large.
 - 1) Set F0-08 to 5.00Hz (target operating frequency).
 - 2) Press RUN. The running indicator is on, and the motor rotates forward at 5.00Hz.
 - 3) Make sure that the motor rotates in the correct direction, and the drive shows no fault. When a fault is displayed, troubleshoot it.
 - 4) Increase the set value of F0-08 to improve the motor operating frequency. When increasing the operating frequency, please confirm the responsiveness and adjust the set value by 10Hz.
 - 5) Press > shift key, the indicator A on the right of the panel will light up, and the panel will display the current output current. If the output current of the drive does not exceed the rated current of the motor, it is in normal state.
 - 6) After confirming that the motor can run properly, press STOP. When the motor stops, the RUN indicator goes out.
 - 7) Change the target frequency and rotation direction, and confirm whether there is abnormal sound and vibration.
 - 8) In case of control failures such as maladjustment or vibration, please make adjustments.

7.10 Adjustment of control performance during test run

Set the basic parameters, and start the test run after self-learning of the motor.

Warning! Safety measures when restarting the machine: After the wiring operation and parameter setting are completed, please be sure to perform test run, and make sure that the machine can operate safely. If the system is used directly without test run, it may cause death or serious injury.

- VF control of induction motor

Failure	Parameter No.	Measures	Factory setting	Recommended value
Maladjustment and vibration occur at medium speed (10 Hz~40 Hz)	F4-11 (oscillation suppression gain)	In case of maladjustment and vibration, raise the set value.	40	0~100
<ul style="list-style-type: none"> ■ Motor is noisy ■ Maladjustment and vibration occur at low speed (below 10 Hz) and medium speed (10 Hz~40 Hz) 	F0-15 (carrier frequency)	<ul style="list-style-type: none"> ■ Motor is noisy, raise the carrier frequency ■ Low and medium speed maladjustment and vibration, lower the carrier frequency 	Model determination	
Insufficient torque at low speed (below 10Hz).	F4-01 (Torque boost)	<ul style="list-style-type: none"> ■ Operating parameters have been identified, and automatic torque boost can be set 	Model determination	0.0% ~ 30.0%

Failure	Parameter No.	Measures	Factory setting	Recommended value
Insufficient torque at low speed (below 10Hz).	F4-01 (Torque boost)	<ul style="list-style-type: none"> ■ Without parameter identification, increase the parameters according to the actual situation 	Model determination	0.0% ~ 30.0%
Large starting impact	F4-01 (Torque boost)	<ul style="list-style-type: none"> ■ According to the actual situation, lower the parameters ■ Perform parameter identification and set it to automatic torque boost 	Model determination	0.0% ~ 30.0%
Large inertia load, and report overvoltage when rapid deceleration	F4-23 (Overvoltage stall enabled)	Enable overvoltage stall protection function	1	
Poor speed accuracy	F4-09 (slip compensation coefficient)	Adjust this compensation value according to the actual situation	0.0%	0.0% ~ 200.0%

● PG-free vector control of induction motor

Failure	Parameter No.	Measures	Factory setting	Recommended value
Slow response of torque and speed	Speed loop proportional gain F3-01 (low speed) F3-04 (high speed)	When the response of torque and speed is slow, lower the set value.	20	1~100
	Speed loop integration time F3-02 (low speed) F3-05 (high speed)	In case of maladjustment and vibration, raise the set value	0.5	0.01~10.00
The proportional gain and time of ASR cannot be ensured at low speed or high speed	F3-03 (speed loop switching frequency 1) F3-06 (speed loop switching frequency 2)	Switch the ASR proportional gain and integration time according to the output frequency	F3-03: 5Hz F3-06: 10Hz	Make adjustments as needed
Large inertia load, and report overvoltage when rapid deceleration	F3-23 (Power generation limit enabled)	Enable the power generation limit function, and adjust F3-24 and F3-25 as required	0	
Poor speed accuracy	F3-07 (Vector control slip gain)	Adjust this compensation value according to the actual situation	100%	50% ~200%
<ul style="list-style-type: none"> ■ Motor is noisy Maladjustment and vibration occur at low speed (below 3Hz)	F0-15 (carrier frequency)	<ul style="list-style-type: none"> ■ Motor is noisy, raise the carrier frequency ■ Maladjustment and vibration at low speed, lower the carrier frequency 	Model determination	

- PG vector control of induction motor

Failure	Parameter No.	Measures	Factory setting	Recommended value
Slow response of torque and speed	Speed loop proportional gain F3-01 (low speed) F3-04 (high speed)	When the response of torque and speed is slow, lower the set value.	20	1~100
	Speed loop integration time F3-02 (low speed) F3-05 (high speed)	In case of maladjustment and vibration, raise the set value	0.5	0.01~10.00
The proportional gain and time of ASR cannot be ensured at low speed or high speed	F3-03 (speed loop switching frequency 1) F3-06 (speed loop switching frequency 2)	Switch the ASR proportional gain and integration time according to the output frequency	F3-03: 5Hz F3-06: 10Hz	Make adjustments as needed
<ul style="list-style-type: none"> ■ Motor is noisy Maladjustment and vibration occur at low speed (below 3 Hz) 	F0-15 (carrier frequency)	<ul style="list-style-type: none"> ■ Motor is noisy, raise the carrier frequency ■ Maladjustment and vibration at low speed, lower the carrier frequency 	Model determination	

7.11 Confirmation table during test run

During the test run, please confirm according to the following steps:

- (1) Before the first test run

Inspection	Ser.No.	Content
	1	Whether the correct installation and wiring is completed according to the specifications
	2	Whether to disconnect the mechanical load connected to the motor shaft
	3	Whether the motor shaft can rotate
	4	Whether the drive is set with automatic start function
	5	Whether the drive is powered on

- (2) First test run

Inspection	Ser.No.	Content
	1	Whether to complete the "heavy load or light load" model setting according to the load characteristics
	2	Whether to set motor parameters
	3	Whether the operating frequency is appropriately reduced, such as 10Hz
	4	Whether the drive can start properly
	5	Whether the motor rotates and whether the motor rotates in the correct direction If the motor rotates in the wrong direction, whether any two-phase U/V/W cables have been exchanged
	6	Whether to complete the motor parameter self-learning

8 Precautions in repair, maintenance and storage

Due to the influence of environmental temperature, humidity, dust and vibration, aging and wear of devices inside the drive and many other reasons, potential failures of the drive will occur. Therefore, it is necessary to carry out daily and regular maintenance of the drive.

Note: Before inspection and maintenance, please confirm the following items first, otherwise it may cause electric shock:

- (1) The power supply of the drive has been cut off;
- (2) After the cover plate is opened, the charging indicator goes out;
- (3) The voltage between DC buses measured by DC voltmeter is less than 36V.

8.1 Daily maintenance and care

Daily inspection: In principle, check whether there is any abnormality during operation:

- 1) Whether the motor runs as set;
- 2) Whether the environment of the installation site is abnormal;
- 3) Whether the cooling system is abnormal;
- 4) Whether there is abnormal vibration sound;
- 5) Whether there is overheating and discoloration;
- 6) Measure the input voltage of drive with multimeter during operation.

8.2 Regular inspection and maintenance

Depending on the use environment, users can check the drive once every 3 or 6 months.

When the drive is regularly maintained and inspected, the power supply must be cut off. After the monitor (keyboard) is not displayed and the power indicator of the main circuit is turned off for 10 minutes, the multimeter is used to detect that the DC bus voltage of and is less than 25V, so as to avoid the residual voltage of the capacitor of the drive from hurting the maintenance personnel.

- (1) Cooling system: Please clean the air filter and check whether the cooling fan is normal.
- (2) Screws and bolts: Due to the influence of vibration and temperature change, the fixed parts such as screws and bolts may be loose. Check whether they are reliably tightened, and tighten them according to the tightening torque.
- (3) Check whether conductors and insulators are corroded or damaged.
- (4) Measure the insulation resistance.
- (5) Check the filter capacitor for discoloration, odor, bubbling, liquid leakage, etc.

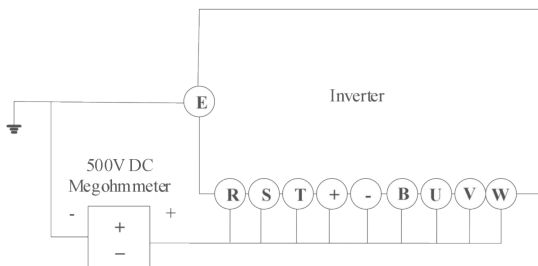

Figure 8.2.1 Insulation Resistance Test of Main Circuit

The drive must be operated according to the specified use environment, and some unexpected situations may occur during operation. Users shall carry out daily maintenance according to the tips in the following table. It is a good way to prolong the service life of the drive to keep a good operating environment, record the daily operation data and find the exception reasons as soon as possible.

Table 8.2.1 Tips for Daily Inspection

Check object	Inspection essentials			Judgment criteria
	Check content	Period	Inspection means	
Operating environment	1. Temperature and humidity	Any time	1. Thermometer and hygrometer	1. (-10 ~ +45)°C, (45 ~ 55)°C for derating
	2. Dust, water and dripping		2. Visual inspection	2. No water leakage trace
	3. Gas		3. Smell	3. No peculiar smell
Drive	1. Vibration, fever	Any time	1. Shell touch	1. Stable vibration and reasonable fan temperature
	2. Noise		2. Hearing	2. No unusual noise
Motor	1. Heating	Any time	1. Hand touch	1. No abnormality in heating
	2. Noise		2. Hearing	2. Uniform noise
Running state parameter	1. Output current	Any time	1. Ammeter	1. In the rated range
	2. Output voltage		2. Voltmeter	2. In the rated range
	3. Internal temperature		3. Thermometer	3. Temperature rise less than 35K

8.3 Replace wearing parts

The wearing parts of drive mainly include cooling fan and electrolytic capacitor for filtering, and their service life is closely related to the use environment and maintenance state. The general service life is shown in the following table.

Table 8.3.1 Component Service Life

Device name	Service life
Fan	(3 ~ 4) 0,000 hours
Electrolytic capacitor	(4 ~ 5) 0,000 hours
Relay	About 100,000 times

Users can determine the replacement period according to the running time.

(1) Cooling fan

Possible causes of damage: Bearing wear and blade aging.

Criterion: Whether there are cracks in the fan blades, etc., and whether there is abnormal vibration sound during startup.

(2) Filter electrolytic capacitor

Possible causes of damage: High ambient temperature, frequent load jump causing increased pulsating current and aging electrolyte.

Criterion: Whether there is liquid leakage, whether the safety valve is protruding, the measurement of electrostatic capacitance and insulation resistance.

(3) Relay

Possible causes of damage: Corrosion, frequent action.

Criterion: On-off failure.

8.4 Storage life and precautions

Users must pay attention to the following for temporary storage and long-term storage after purchasing the drive:

- (1) Avoid storing it in places with high temperature, humidity and rich dust and metal dust, and ensure good ventilation;
- (2) The drive stored for a long time must be electrified once within 2 years. When electrified, use the voltage regulator to slowly rise to the rated value, and electrify the drive for 1 hour without load.

9 Fault analysis and elimination

The following fault types may be encountered during the use of the drive. Please refer to the following methods for simple fault analysis:

Table 9.1.1 Common Fault Codes of Drive and Troubleshooting Methods

Fault name	Panel display	Troubleshooting	Fault handling measures
Accelerated overcurrent	E.OC1 (Fault code 02)	The drive output circuit is grounded or short-circuited	<ul style="list-style-type: none"> Eliminate peripheral faults, and detect whether the motor or interrupt contactor is short-circuited
		The control mode is FVC or SVC without parameter identification	<ul style="list-style-type: none"> Set the motor parameters according to the motor nameplate and identify the motor parameters
		Under the rapid acceleration condition, the acceleration time is set too short	<ul style="list-style-type: none"> Increase the acceleration time
		The overcurrent stall suppression setting is not appropriate	<ul style="list-style-type: none"> Confirm that the overcurrent stall suppression function (F4-19) has been enabled; The set value of the overcurrent stall action current (F4-18) is too large, and it is recommended to adjust it within 120% to 150%; The overcurrent stall suppression gain (F4-20) is set too small, and it is recommended to adjust it within 20 to 40;
		The manual torque boost or V/F curve is inappropriate	<ul style="list-style-type: none"> Adjust the manual boost torque or V/F curve
		Start the rotating motor	<ul style="list-style-type: none"> Select the speed tracking start or wait for the motor to stop before starting
		Subject to external interference	<ul style="list-style-type: none"> Check the historical fault records. If the current value is far from the overcurrent point value at the time of fault, find the interference source. If there is no other interference source, it may be the driving board or hall element problem.
Decelerated overcurrent	E.OC2 (Fault code 03)	The drive output circuit is grounded or short-circuited	<ul style="list-style-type: none"> Eliminate peripheral faults and detect whether the motor is short-circuited or open-circuited
		The control mode is FVC or SVC without parameter identification	<ul style="list-style-type: none"> Set the motor parameters according to the motor nameplate and identify the motor parameters
		In case of sudden deceleration, the deceleration time is set too short	<ul style="list-style-type: none"> Increase deceleration time

Fault name	Panel display	Troubleshooting	Fault handling measures
Decelerated overcurrent	E.OC2 (Fault code 03)	The overcurrent stall suppression setting is not appropriate	<ul style="list-style-type: none"> Confirm that the overcurrent stall suppression function (F4-19) has been enabled; The set value of the overcurrent stall action current (F4-18) is too large, and it is recommended to adjust it within 120% to 150%; The overcurrent stall suppression gain (F4-20) is set too small, and it is recommended to adjust it within 20 to 40;
		No braking unit and braking resistor are installed	<ul style="list-style-type: none"> Add braking unit and resistor
		Subject to external interference	<ul style="list-style-type: none"> Check the historical fault records. If the current value is far from the overcurrent point value at the time of fault, find the interference source. If there is no other interference source, it may be the driving board or hall element problem.
Constant speed overcurrent	E.OC3 (Fault code 04)	The drive output circuit is grounded or short-circuited	<ul style="list-style-type: none"> Eliminate peripheral faults and detect whether the motor is short-circuited or open-circuited
		The control mode is FVC or SVC without parameter identification	<ul style="list-style-type: none"> Set the motor parameters according to the motor nameplate and identify the motor parameters
		The overcurrent stall suppression setting is not appropriate	<ul style="list-style-type: none"> Confirm that the overcurrent stall suppression function (F4-19) has been enabled; The set value of the overcurrent stall action current (F4-18) is too large, and it is recommended to adjust it within 120% to 150%; The overcurrent stall suppression gain (F4-20) is set too small, and it is recommended to adjust it within 20 to 40;
		Drive type selected is too small	<ul style="list-style-type: none"> In the stable running state, if the running current has exceeded the rated current of the motor or the rated output current of the drive, please select a drive with a higher power level
		Subject to external interference	<ul style="list-style-type: none"> Check the historical fault records. If the current value is far from the overcurrent point value at the time of fault, find the interference source. If there is no other interference source, it may be the driving board or hall element problem.

Fault name	Panel display	Troubleshooting	Fault handling measures
Accelerated overvoltage	E.OU1 (Fault code 05)	The input voltage is too high	<ul style="list-style-type: none"> Adjust the voltage to the normal range
		There is an external force to drag the motor to run during acceleration	<ul style="list-style-type: none"> Cancel the external force or install a braking resistor
		The overvoltage suppression setting is not appropriate	<ul style="list-style-type: none"> Confirm that the overvoltage suppression function (F4-23) has been enabled; The set value of overvoltage suppression action voltage (F4-22) is too large, and it is recommended to adjust it within 700V~770V for 380V models and 350V~380V for 220V models; The overvoltage suppression gain (F4-24) is set too small, and it is recommended to adjust it within 30 to 50;
		No braking unit and braking resistor are installed	<ul style="list-style-type: none"> Add braking unit and resistor
		The acceleration time is too short	<ul style="list-style-type: none"> Increase the acceleration time
Decelerated overvoltage	E.OU2 (Fault code 06)	The overvoltage suppression setting is not appropriate	<ul style="list-style-type: none"> Confirm that the overvoltage suppression function (F4-23) has been enabled; The set value of overvoltage suppression action voltage (F4-22) is too large, and it is recommended to adjust it within 700V~770V for 380V models and 350V~380V for 220V models; The overvoltage suppression gain (F4-24) is set too small, and it is recommended to adjust it within 30 to 50;
		There is an external force to drag the motor to run during deceleration	<ul style="list-style-type: none"> Cancel the external force or install a braking resistor
		Deceleration time is too short	<ul style="list-style-type: none"> Increase deceleration time
		No braking unit and braking resistor are installed	<ul style="list-style-type: none"> Add braking unit and resistor
Constant speed overvoltage	E.OU3 (Fault code 07)	The overvoltage suppression setting is not appropriate	<ul style="list-style-type: none"> Confirm that the overvoltage suppression function (F4-23) has been enabled; The set value of overvoltage suppression action voltage (F4-22) is too large, and it is recommended to adjust it within 700V~770V for 380V models and 350V~380V for 220V models; The overvoltage suppression frequency gain (F4-24) is set too small, and it is recommended to adjust it within 30 to 50; The maximum rising frequency of overvoltage suppression (F4-26) is set too small, so it is recommended to adjust it within 5~20Hz;
		There is an external force to drag the motor to run during running	<ul style="list-style-type: none"> Cancel the external force or install a braking resistor

Fault name	Panel display	Troubleshooting	Fault handling measures
Buffer power fault	E.RES (Fault code 08)	Bus voltage fluctuates at the undervoltage point	<ul style="list-style-type: none"> Seek technical support
Undervoltage fault	E.UV (Fault code 09)	Momentary power failure	<ul style="list-style-type: none"> Enable the instant stop function (FE-59) to prevent instantaneous power failure and undervoltage fault
		The input terminal voltage of the drive is not in the range required by the specification	<ul style="list-style-type: none"> Adjust the voltage to the normal range
		Bus voltage is not normal	<ul style="list-style-type: none"> Seek technical support
		Rectifier bridge, buffer resistor, drive board and control board are abnormal	<ul style="list-style-type: none"> Seek technical support
Drive overload	E.OL2 (Fault code 10)	Whether the load is too large or the motor is locked	<ul style="list-style-type: none"> Reduce the load and check the motor and mechanical condition
		Drive type selected is too small	<ul style="list-style-type: none"> Select an drive with higher power level
Motor overload	E.OL1 (Fault code 11)	Whether the motor protection parameter FE-01 is set properly	<ul style="list-style-type: none"> Set this parameter correctly
		Whether the load is too large or the motor is locked	<ul style="list-style-type: none"> Reduce the load and check the motor and mechanical condition
Input open-phase	E.SPI (Fault code 12)	The three-phase input power supply is abnormal	<ul style="list-style-type: none"> Check and eliminate the problems in the peripheral circuit
		Driving board, lightning protection board, main control board and rectifier bridge are abnormal	<ul style="list-style-type: none"> Seek technical support
Output open-phase	E.SPO (Fault code 13)	Motor fault	<ul style="list-style-type: none"> Detect whether the motor is open circuited
		The lead from the drive to the motor is abnormal	<ul style="list-style-type: none"> Troubleshoot the peripheral faults
		The three-phase output of the drive is unbalanced when the motor is running	<ul style="list-style-type: none"> Check whether the three-phase winding of the motor is normal and troubleshoot if any
		Driving board and IGBT module are abnormal	<ul style="list-style-type: none"> Seek technical support
Module overheating	E.OH1 (Fault code 14)	Too high ambient temperature	<ul style="list-style-type: none"> Reduce the ambient temperature
		Air duct blockage	<ul style="list-style-type: none"> Clean the air duct
		Fan damage	<ul style="list-style-type: none"> Replace the fan
		The module thermistor is damaged	<ul style="list-style-type: none"> Seek service from manufacturers
		The inversion module is damaged	<ul style="list-style-type: none"> Seek service from manufacturers
External equipment failure	E.EF (Fault code 15)	Input the external fault signal through multi-function terminal X	<ul style="list-style-type: none"> Troubleshoot peripheral faults, confirm that the machine is allowed to be restarted (F8-18), and reset for operation
		Input the signal of external fault through virtual IO function	<ul style="list-style-type: none"> Confirm that the parameters of A0 virtual IO group are set correctly, and reset for operation

Fault name	Panel display	Troubleshooting	Fault handling measures
Communication fault	E.CE (Fault code 16)	The upper computer is not working properly	<ul style="list-style-type: none"> Check the upper computer wiring
		The communication line is not normal	<ul style="list-style-type: none"> Inspect the communication cables
		Communication optional card Fb-00 is not set correctly	<ul style="list-style-type: none"> Correctly set the communication optional card type
		The communication parameter Fb group is set incorrectly	<ul style="list-style-type: none"> Correctly set the communication parameters
		After the above detection is completed, if the fault still cannot be eliminated, you can try to restore the factory settings.	
Contactor fault	E.SHT (Fault code 17)	Driving board and power supply are abnormal	<ul style="list-style-type: none"> Seek service from manufacturers
		Contactor is abnormal	<ul style="list-style-type: none"> Seek service from manufacturers
		Lightning protection board is abnormal	<ul style="list-style-type: none"> Seek service from manufacturers
Current detection fault	E.ITE (Fault code 18)	Check hall element abnormality	<ul style="list-style-type: none"> Seek service from manufacturers
		Driving board is abnormal	<ul style="list-style-type: none"> Seek service from manufacturers
Motor tuning fault	E.TE (Fault code 19)	The motor parameters are not set according to the nameplate	<ul style="list-style-type: none"> Correctly set the motor parameters according to the nameplate
		Parameter identification process timed out	<ul style="list-style-type: none"> Check the drive to motor lead
			<ul style="list-style-type: none"> Check whether the number of encoder lines is set correctly Fd-00, and check whether the signal lines of the encoder are connected correctly and firmly
Encoder fault	E.ENCD (Fault code 20)	Encoder model mismatch	<ul style="list-style-type: none"> Set the encoder type correctly according to the actual situation
		Encoder wiring error	Detect the power supply and phase sequence of PG card
		Encoder is damaged	Replace encoder
		PG card is abnormal	Replace PG card
EEPROM Read-write fault	E.EEP (Fault code 21)	EEPROM chip is damaged	<ul style="list-style-type: none"> Seek service from manufacturers
Short circuit fault to ground	E.STG (Fault code 23)	Motor short circuit to ground	<ul style="list-style-type: none"> Replace cable or motor
Run-time PID feedback overshoot	E.FBH (Fault code 24)	PID feedback is more than F9-29 set value	<ul style="list-style-type: none"> Check the PID feedback signal or set F9-29 to an appropriate value
Fault of cumulative running time reached	E.RTO (Fault code 26)	The cumulative running time reaches the set value	<ul style="list-style-type: none"> Use the parameter initialization function to clear the recorded information

Fault name	Panel display	Troubleshooting	Fault handling measures
User-defined fault 1	E.US1 (Fault code 27)	Input user-defined fault 1 signal through multi-function terminal X	<ul style="list-style-type: none"> Reset for operation
		Input user-defined fault 1 signal through virtual IO function	<ul style="list-style-type: none"> Reset for operation
User-defined fault 2	E.US2 (Fault code 28)	Input user-defined fault 2 signal through multi-function terminal X	<ul style="list-style-type: none"> Reset for operation
		Input user-defined fault 2 signal through virtual IO function	<ul style="list-style-type: none"> Reset for operation
Power-on time reached	E.PTO (Fault code 29)	The power-on time of the drive reaches the time set by F8-16	<ul style="list-style-type: none"> Clear the F8-16 sett value
Unloading fault	E.LL (Fault code 30)	The running current of drive is less than FE-67	<ul style="list-style-type: none"> Confirm whether the load is disengaged or whether the parameter settings of FE-67 and FE-68 conform to the actual operating conditions
PID feedback loss fault during running	E.FBL (Fault code 31)	PID feedback is less than F9-26 set value	<ul style="list-style-type: none"> Check the PID feedback signal or set F9-26 to an appropriate value
Wave-by-wave current limiting fault	E.CBC (Fault code 40)	Whether the load is too large or the motor is locked	<ul style="list-style-type: none"> Reduce the load and check the motor and mechanical condition
		Drive type selected is too small	<ul style="list-style-type: none"> Select an drive with higher power level
Switching motor fault during running	E.SR (Fault code 41)	Change the current motor selection through the terminal during the running of the drive	<ul style="list-style-type: none"> Switch the motor after the drive stops.
Excessive speed deviation fault	E.DEV (Fault code 42)	The encoder parameters are set incorrectly	<ul style="list-style-type: none"> Correctly set the encoder parameters
		No parameter identification is performed	<ul style="list-style-type: none"> Carry out motor parameter identification
		If the speed deviation is excessive, the detection parameters FE- 72 and FE-73 are set unreasonably	<ul style="list-style-type: none"> Set the detection parameters reasonably according to the actual situation
Motor overspeed fault	E.OS (Fault code 43)	The encoder parameters are set incorrectly	<ul style="list-style-type: none"> Correctly set the encoder parameters
		No parameter identification is performed	<ul style="list-style-type: none"> Carry out motor parameter identification
		The setting of motor overspeed detection parameters FE-70 and FE-71 is unreasonable	<ul style="list-style-type: none"> Set the detection parameters reasonably according to the actual situation
Module overtemperature fault	E.OH2 (Fault code 45)	The wiring of temperature sensor is loose	<ul style="list-style-type: none"> Check the wiring of temperature sensor and troubleshoot it
		Too high motor temperature	<ul style="list-style-type: none"> Increase the carrier frequency or take other cooling measures to cool the motor

Fault name	Panel display	Troubleshooting	Fault handling measures
Initial position detection error	E.POS (Fault code 51)	When using synchronous motor SVC vector control, the connection between drive and motor is incorrect	<ul style="list-style-type: none"> • Detect the output wiring of drive
Master-slave control slave fault	E.P2P (Fault code 55)	Slave is faulty. Check the slave	<ul style="list-style-type: none"> • Troubleshoot according to the slave fault code
Braking unit overload	E.BOL (Fault code 61)	The brake resistance value is too small	<ul style="list-style-type: none"> • Please refer
The brake circuit is short	E.BSH (Fault code 62)	The brake module is abnormal	<ul style="list-style-type: none"> • Seek technical support

10 Warranty period and environmental protection and other legal provisions

10.1 Warranty period

Under normal storage and transportation conditions, and the product packaging is intact or the product itself is intact, the warranty period is 12 months from the date of purchase by the user or 18 months from the date of production, whichever comes first.

The following situations are not covered by the warranty:

- 1) Damage caused by improper use, storage and maintenance of users;
- 2) Damage caused by institutions or personnel not appointed by the Company or their disassembly and maintenance without permission;
- 3) The product exceeds the warranty period;
- 4) Damage caused by force majeure;
- 5) When the bar code, nameplate and other marks identified by the manufacturer in the product are damaged or unrecognizable;
- 6) When the user fails to pay the purchase price according to the Sales Contract signed by both parties;
- 7) When the user intentionally conceals the improper use of the product in the installation, wiring, operation, maintenance or other processes from the after-sales service provider of the manufacturer.
- 8) Our company has the right to entrust others to provide warranty services of the faulty products, and the relevant service fees are calculated according to the actual costs. If there is an agreement, the agreement shall prevail.
- 9) Our sales and agency in China can provide after-sales service for this product.

10.2 Environmental protection

In order to protect the environment, when this product or any of its components is scrapped, please dispose of it properly as industrial waste; Or hand it over to the recycling station for classification, disassembly, recycling and reuse in accordance with relevant national regulations.

11 Product selection and ordering instructions

11.1 Heavy load rating and light load rating

NVF7 Series Drive can meet two kinds of load applications: heavy load (T-type) and light load (P-type). The main differences between heavy load applications and light load applications are shown in the following table.

Table 11.1.1 Heavy Load Rating (T-type) and Light Load Rating (P-type)

Load	Corresponding torque characteristics	Common load	Overload capacity	Parameter setting
Heavy load	Constant torque	Extruder Conveyor belt Crane-lifting, translation Other constant torque or high overload applications	150% rated current under heavy load for 60s Allow 1 overload every 10 minutes	F0-00=1
Light load	Variable torque	Fan Water pump Other variable torque or light load applications	110% rated current under light load for 60s Allow one overload every 10 minutes	F0-00=2

11.2 Derating of drive

When selecting and using the product, please ask users to determine whether to derate it according to the actual use situation. Derating is considered mainly in the following circumstances:

- ◆ Ambient temperature and derating

When the ambient temperature exceeds 40°C, it needs to be derated. It shall be derated by 1.5% for every 1°C increase in ambient temperature, and the maximum ambient temperature is 50°C.

- ◆ Altitude and derating

In the area where the altitude exceeds 1000m, the heat dissipation effect of the drive becomes worse due to the thin air, so it needs to be derated (it shall be derated by 1% for every increase of 100m in altitude, and the maximum altitude is 3000m).

- ◆ Parallel operation and derating

When multiple drives are connected in parallel and installed compactly (the interval between two drives is less than 5mm), they need to be derated by 70%-80% according to the actual application environment.

Please consult our company for details.

11.3 Other optional accessories

Other supported optional accessories are shown in the following table.

Table 11.3.1 Other Optional Accessories

Name	Model	Applicable model	Remarks
Display extension cable (network cable) Operation panel extension cable	VA7CB04	Whole series	
Display extension cable (network cable) Operation panel extension cable	VA7CB02	Whole series	
LED operation panel LED Operation panel	VA7KEY01	Whole series	
LCD operation panel LCD Operation panel	VA7KEY02	Whole series	
Panel mounting bracket Operation panel mounting bracket	VA7KEY03	Whole series	

11.4 Selection of peripheral devices of the main circuit

In the application of drive products, it plays an important role in the reliable operation of the product to reasonably select the appropriate peripheral devices of the main circuit. For the selection of peripheral devices of the main circuit, please refer to the product selection catalogue of our company. For details, please consult the agent distributor or sales manager.

Table 11.4.1 Types of Peripheral Devices of Main Circuit

Name	Model	Description
Breaker	General	The time characteristics of the circuit breaker shall fully consider the time characteristics of the drive overload protection, and the capacity of the circuit breaker is 1.2~2 times of the rated current of the drive; In order to avoid the power grid impact caused by short circuit or internal fault at the output end of the drive, a circuit breaker must be installed at the input end of the drive.
Contactors	General	In order to ensure safety, please use contactors, but do not control the start and stop of the drive through contactors. Frequent connection and disconnection of contactors will reduce the service life of the drive.
Input AC reactor	ACL series	Please connect the AC reactor at the input end of the drive or install the DC reactor at the terminal of the DC reactor in case of any of the following circumstances 1. The power supply of the drive is more than 600kVA or the power supply capacity is more than 10 times that of the drive; 2. Where there is a switched reactive power compensation capacitor or a thyristor-controlled load on the same power supply node, and a large peak current will flow into the input power supply circuit, which will cause damage to some rectifier devices; 3. When the voltage imbalance of the three-phase power supply of the drive exceeds 3%, which will cause damage to some rectifier devices; 4. The input power factor of the drive is required to be greater than 90%.
Input noise filter	General	The noise of the drive from the power input end can be reduced, and the noise from the drive output to the power end can also be reduced.
DC reactor	DCL series	Please connect the AC reactor at the input end of the drive or install the DC reactor at the terminal of the DC reactor in case of any of the following circumstances 1. The power supply of the drive is more than 600kVA or the power supply capacity is more than 10 times that of the drive; 2. Where there is a switched reactive power compensation capacitor or a thyristor-controlled load on the same power supply node, and a large peak current will flow into the input power supply circuit, which will cause damage to some rectifier devices; 3. When the voltage imbalance of the three-phase power supply of the drive exceeds 3%, which will cause damage to some rectifier devices; 4. The input power factor of the drive is required to be greater than 90%.
Output noise filter	General	Connecting a noise filter to the output of the drive can reduce the conduction and radiation interference.
Output AC reactor	OCL series	When the connecting line from the drive to the motor is more than 100 m, it is suggested to install an AC output reactor that can suppress high-frequency oscillation, in order to avoid motor insulation damage, excessive leakage current and frequent protection of the drive.
Output noise filter	General	Connecting a noise filter to the output of the drive can reduce the conduction and radiation interference.
External braking unit	General	For medium-high power drive without built-in braking unit, or multiple drives sharing DC bus, the load motor has a large feedback energy.
Braking resistor	General	The mechanical energy in the process of motor braking can be consumed in the form of heat energy through the braking resistor, which can shorten the deceleration time of the drive transmission system.

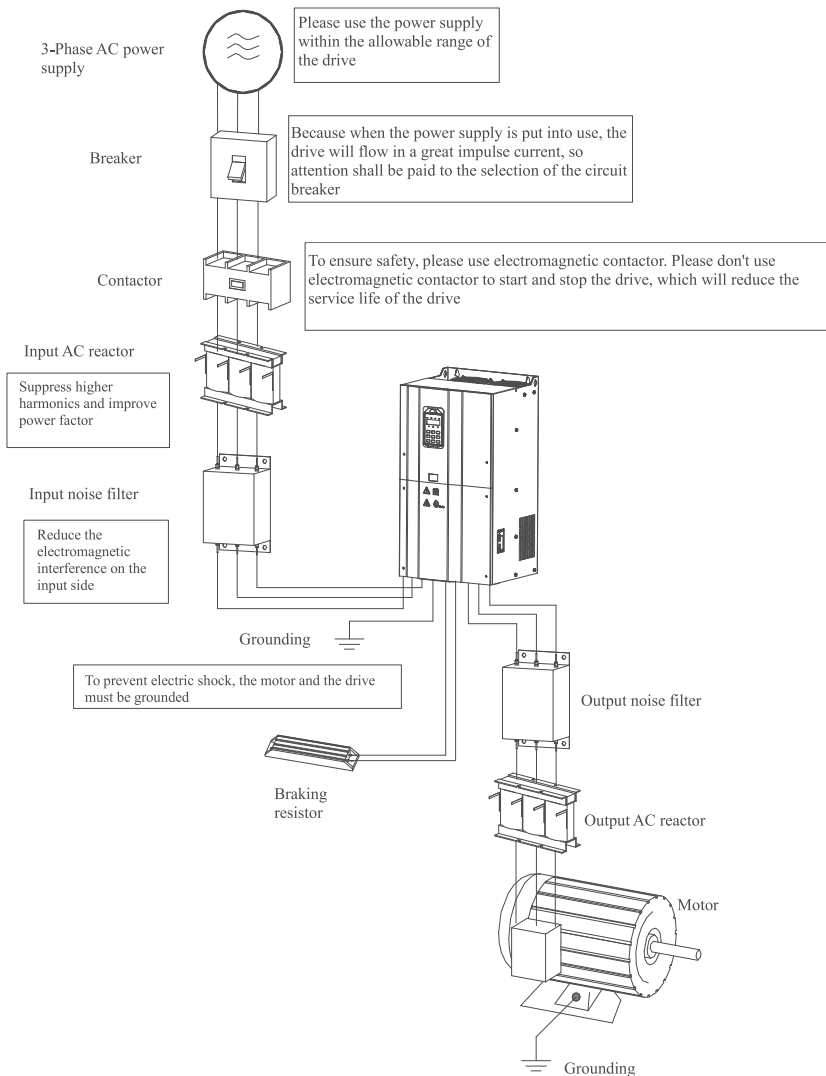

Figure 11.4.1 Product and Peripheral Devices

11.4.1 Circuit breaker, contactor

Table 11.4.2 Selection of Circuit Breaker, Contactor for three-phase 380 V Products

Adaptive 380V motor power kW	Recommended circuit breaker		Recommended circuit breaker	
	Model	Rated current /A	Model	Rated current /A
0.4	NB1-63 3P C4	4	NC8-06M	9
0.75	NB1-63 3P C4	4	NC8-06M	9
1.5	NB1-63 3P C6	6.3	NC8-09M	9
2.2	NB1-63 3P C10	16	NC8-18	16
3.0	NB1-63 3P C16	25	NC8-18	16
4.0				
5.5	NB1-63 3P C25	32	NC8-32	26
7.5	NB1-63 3P C32	32	NC8-32	32
11	NB1-63 3P C50	50	NC8-40	40
15	NB1-63 3P C63	63	NC8-65	65
18.5	NB1-63 3P C63	80	NC8-100	95
22	NM8-100S/80/3	80	NC8-100	95
30	NM8-100S/80/3	125	NC8-115	115
37	NM8-100S/125/3	125	NC8-115	115
45	NM8-250S/160/3	150	NC8-205	185
55	NM8-250S/180/3	175	NC8-205	185
75	NM8-250S/225/3	220	NC8-265	225
90	NM8-250S/250/3	250	NC8-265	300
110	NM8-630S/315/3	300	NC8-265	300
132	NM8-630S/350/3	350	NC8-400	400
160	NM8-630S/400/3	400	NC8-400	400
185	NM8-630S/500/3	500	NC8-400	400
200	NM8-630S/500/3	500	Ex9C 600	600
220	NM8-1250S/630/3	630	Ex9C 600	600
250	NM8-1250S/630/3	630	Ex9C 600	600
280	NM8-1250S/800/3	800	Ex9C 800	800
315	NM8-1250S/800/3	800	Ex9C 800	800
355	NM8-1250S/800/3	800	Ex9C 800	800

Table 11.4.3 Selection of Circuit Breaker, Contactor for three-phase 230 V Products

Adaptive 230V motor power kW	Recommended circuit breaker		Recommended circuit breaker	
	Model	Rated current /A	Model	Rated current /A
0.4	NB1-63 3P C4	4	NC8-06M	9
0.75	NB1-63 3P C4	6.3	NC8-06M	9
1.5	NB1-63 3P C6	16	NC8-18	16
2.2	NB1-63 3P C10	25	NC8-18	16
3.0	NB1-63 3P C16	32	NC8-32	26
4.0				
5.5	NB1-63 3P C25	50	NC8-32	32
7.5	NB1-63 3P C32	63	NC8-50	50
11	NM8-100S/80/3	80	NC8-100	95
15	NM8-100S/80/3	125	NC8-100	95
18.5	NM8-250S/160/3	150	NC8-100	95
22	NM8-250S/160/3	150	NC8-115	115
30	NM8-250S/180/3	175	NC8-205	185

Adaptive 230V motor power kW	Recommended circuit breaker		Recommended circuit breaker	
	Model	Rated current /A	Model	Rated current /A
37	NM8-250S/225/3	220	NC8-205	185
45	NM8-250S/250/3	250	NC8-265	225
55	NM8-630S/315/3	300	NC8-265	300

11.4.2 Reactor

Table 11.4.4 Selection of Reactor for 380 V Products

380V Motor power	Input Reacto	Output Reactor
1.5 kW	ACL-0005-EISC-2	OCL-0005-EISC-1
2.2 kW	ACL-0007-EISC-2	OCL-0005-EISC-1
3.7 kW	ACL-0010-EISC-2	OCL-0010-EISC-1
5.5 kW	ACL-0015-EISCL-2	OCL-0015-EISCL-1
7.5 kW	ACL-0020-EISCL-2	OCL-0015-EISCL-1
11 kW	ACL-0030-EISCL-2	OCL-0030-EISCL-1
15 kW	ACL-0040-EISCL-2	OCL-0030-EISCL-1
18.5 kW	ACL-0040-EISCL-2	OCL-0040-EISCL-1
22 kW	ACL-0050-EISCL-2	OCL-0050-EISCL-1
30 kW	ACL-0060-EISCL-2	OCL-0060-EISCL-1
37 kW	ACL-0090-EISCL-2	OCL-0080-EISCL-1
45 kW	ACL-0090-EISCL-2	OCL-0090-EISCL-1
55 kW	ACL-0120-EISCL-2	OCL-0120-EISCL-1
75 kW	ACL-0150-EISCL-2	OCL-0150-EISCL-1
90 kW	ACL-0200-EISCL-2	OCL-0200-EISCL-1
110 kW	ACL-0250-EISH-2	OCL-0200-EISCL-1
132 kW	ACL-0250-EISH-2	OCL-0250-EISH-1
160 kW	ACL-0330-EISH-2	OCL-0330-EISH-1
185 kW	ACL-0390-EISH-2	OCL-0330-EISH-1
200 kW	ACL-0390-EISH-2	OCL-0390-EISH-1
220 kW	ACL-0490-EISH-2	OCL-0490-EISH-1
245 kW	ACL-0490-EISH-2	OCL-0490-EISH-1
280 kW	ACL-0600-EISH-2	OCL-0530-EISH-1
315 kW	ACL-0600-EISH-2	OCL-0600-EISH-1
355 kW	ACL-0800-EISH-2	OCL-0660-EISH-1
400 kW	ACL-0800-EISH-2	OCL-1000-EISH-1
450 kW	ACL-1000-EISH-2	OCL-1000-EISH-1

11.4.3 Braking unit and braking resistor

Table 11.4.5 Selection of built-in braking units and braking resistors for 380V Products

380V Drive Specifications	Brake Unit Configuration	125% braking torque suitable braking resistance value (Ω)	Braking resistor power dissipation (kW)		Allowable minimum braking resistance value (Ω)
			10% utilization rate	50% utilization rate	
0.4T/0.75P-S4-B(1)	Standard built-in	1000	0.3	1.5	200
0.75T/1.1P-S4-B(1)		625	0.45	2.25	200
1.1T/1.5P-S4-B(1)		475	0.6	3	200
1.5T/2.2P-S4-B(1)		325	0.23	1.15	170
2.2T/3.0P-S4-B(1)		222	0.33	1.65	130
3.0T/4.0P-S4-B(1)		190	0.46	2.3	100

380V Drive Specifications	Brake Unit Configuration	125% braking torque suitable braking resistance value (Ω)	Braking resistor power dissipation (kW)		Allowable minimum braking resistance value (Ω)
			10% utilization rate	50% utilization rate	
4.0T/5.5P-S4-B(1)	Standard built-in	122	0.6	3	80
5.5T/7.5P-S4-B(1)		89	0.75	4.1	60
7.5T/11P-S4-B(1)		65	1.1	5.6	47
11T/15P-S4-B(1)		44	1.7	8.3	31
15T/18.5P-S4-B(1)		32	2	11	23
18.5T/22P-S4-B(1)		30	3	14	23
22T/30P-S4-B(1)		27	3.4	17	23
30T/37P-S4-B(1)	Optional built-in	20	5	23	17
37T/45P-S4-B(1)		16	6	28	17
45T/55P-S4-B(1)		13	7	34	9.6
55T/75P-S4-B(1)		10.5	8	41	9.6
75T/90P-S4-B(1)		7.7	11	56	6.8
90T/110P-S4-B(1)		5.4	14	68	6.8
110T/132P-S4-B(1)		4.7	17	83	6.8

Table 11.4.6 Selection of built-in braking units and braking resistors for 230V Products

230V Drive Specifications	Brake Unit Configuration	125% braking torque suitable braking resistance value (Ω)	Braking resistor power dissipation (kW)		minimum braking resistance value (Ω)
			10% utilization rate	50% utilization rate	
0.4T/0.75P-S2-B	Standard built-in	625	0.45	2.25	200
0.75T/1.1P-S2-B		325	0.6	3	200
1.1T/1.5P-S2-B		222	0.23	1.15	170
1.5T/2.2P-S2-B		190	0.33	1.65	130
2.2T/3.0P-S2-B		89	0.46	2.3	100
3.0T/4.0P-S2-B		74	1.1	5.6	65
4.0T/5.5P-S2-B		65	1.1	5.6	47
5.5T/7.5P-S2-B		44	1.7	8.3	31
7.5T/9.5P-S2-B		32	2	11	23
9.5T/11P-S2-B		30	3	14	23
11T/15P-S2-B		27	3.4	17	23
15T/18.5P-S2(-B)		Optional built-in	20	5	23
18.5T/22P-S2(-B)	16		6	28	17
22T/30P-S2(-B)	13		7	34	9.6
30T/37P-S2(-B)	10.5		8	41	9.6
37T/45P-S2(-B)	7.7		11	56	6.8
45T/55P-S2(-B)	5.4		14	68	6.8

Note

- (1) The wiring length of the brake unit should not exceed 10 meters, and twisted-pair wires or close twin wires should be used for parallel wiring.
- (2) When connecting an external brake unit or an external brake resistor, change the "Overvoltage stall selection" to "Prohibit"; otherwise, the unit will not stop within the set deceleration time.

12 Parameter details

12.1 F0 group Basic functions

F0-00	TP type setting		Factory value	1	Attribute	•
	Setting range	1	T-type (constant torque load model)			
2		P type (fan, water pump load type)				

This parameter can be changed in shutdown state. After modifying this parameter, the relevant parameters of drive model and motor will be automatically modified.

F0-01	The first motor control mode		Factory value	0	Attribute	•
	Setting range	0	Sensorless vector control (SVC)			
		1	Flux Vector Control (FVC)			
2		V/F control				

0: Sensorless vector control is suitable for high performance control occasions.

1: Flux vector control, the motor end must be equipped with an encoder, and the drive must be equipped with the same type of PG card as the encoder. It is suitable for high-precision speed control or torque control.

2: V/F control is suitable for situations where the load requirements are not high, or one drive drives multiple motors, such as fans and pumps.

F0-02	Run instruction selection		Factory value	0	Attribute	○
	Setting range	0	Operation panel command			
		1	Terminal command			
2		Communication command				

When the operation panel command is selected, the LOC/REM indicator goes out; When the terminal command is selected, the LOC/REM indicator lights up; When the communication command is selected, the LOC/REM indicator flashes.

F0-03	Main frequency X instruction selection		Factory value	0	Attribute	•
	Setting range	0	Digital setting (without power-off memory)			
		1	Digital setting (with power-off memory)			
		2	AI1			
		3	AI2			
		4	AI3			
		5	Pulse setting (HDI)			
		6	Multi-segment instruction			
		7	Simple PLC			
		8	PID			
9		Communication setting				

0: Digital setting (without power-off memory)

The initial value of the set frequency is the value of F0-08 "preset frequency". The set frequency value of the drive can be modified by the ▲ key and ▼ key of the keyboard (or the UP and DOWN of the multi-function input terminal). When the drive is powered off and powered on again, the set frequency value is restored to F0-08 "digital setting preset frequency".

1: Digital setting (with power-off memory)

The initial value of the set frequency is the value of F0-08 "preset frequency". The set frequency value of the drive can be modified by the ▲ key and ▼ key of the keyboard (or the UP and DOWN of the multi-function input terminal). When the drive is powered off and powered on again, set the frequency value as the modified value.

2: AI1

3: AI2

4: AI3

The frequency is given through the analog input terminal.

5: Pulse given (HDI)

Frequency is set by high-speed pulse at terminal HDI. Pulse set signal specifications: voltage range 9V~30V, frequency range 0 kHz ~ 100 kHz.

The relationship between the input pulse frequency of HDI terminal and the corresponding setting is set through F5-28~F5-31, and 100.0% of the corresponding setting of pulse input refers to the percentage of the maximum frequency F0-10.

6: Multi-segment instruction

When selecting multi-segment instruction operation mode, through different state combinations of digital input X terminal, correspond to different set frequency values. Four multi-segment instruction terminals can be set, with 16 states of the 4 terminals, corresponding to any 16 "multi-segment instructions" through FA group function codes, and "multi-segment instructions" are the percentage of the maximum frequency F0-10.

7: Simple PLC

When the frequency source is simple PLC, the operating frequency of the drive can be switched between 1~16 arbitrary frequency instructions, and the holding time of 1~16 frequency instructions and their respective acceleration and deceleration time can also be set by the user. For details, please refer to the relevant instructions of FA group.

8: PID

Process PID control is a common method of process control. By proportional, integral and differential operation of the difference between the feedback signal of the controlled quantity and the target signal, the output frequency of the drive is adjusted to form a closed-loop system, so that the controlled quantity can be stabilized at the target value. When using PID as frequency source, it is necessary to set the related parameters of F9 group "PID function".

9: Communication setting

When the communication setting is as a frequency source, it is necessary to set the communication related parameters of Fb group.

F0-04	Auxiliary frequency Y instruction selection		Factory value	0	Attribute	*	
	Setting range	0	Digital setting (without power-off memory)				
		1	Digital setting (with power-off memory)				
		2	AI1				
		3	AI2				
		4	AI3				
		5	Pulse setting (HDI)				
		6	Multi-segment instruction				
		7	Simple PLC				
		8	PID				
9		Communication setting					

When the auxiliary frequency source is used as an independent frequency set channel (that is, the frequency source is selected to switch from X to Y), its usage is the same as that of the main frequency source X. For usage, please refer to the relevant instructions of F0-03.

F0-05	Auxiliary frequency instruction range selection		Factory value	0	Attribute	o
	Setting range	0	Relative to the maximum frequency			
1		Relative to main frequency source X				
F0-06	Auxiliary frequency instruction range		Factory value	100%	Attribute	o
	Setting range		0% ~ 150%			

When the auxiliary frequency source is set by analog input (AI1, AI2, AI3) or pulse input, 100% of the input setting corresponds to the auxiliary frequency source range, which can be set by F0-05 and F0-06.

If F0-05 is selected as the maximum frequency, 100% of the auxiliary frequency corresponds to F0-10; If that relative to the main frequency source is selected, the range of the auxiliary frequency source will change along with the change of the main frequency X.

F0-07	Primary and auxiliary frequency superposition selection		Factory value	0	Attribute	○
	Setting range	Units	Frequency source selection			
		0	Main frequency source X			
		1	Main and auxiliary operation results (the operation relationship is determined by tens)			
		2	The main frequency source X is switched with the auxiliary frequency source Y			
		3	The main frequency source X is switched with the main and auxiliary operation results			
		4	The auxiliary frequency source Y is switched with the main and auxiliary operation results			
		Tens	Main and auxiliary frequency operation relation			
		0	Main + Auxiliary			
		1	Main - Auxiliary			
		2	Maximum of the two			
		3	Minimum of the two			

The frequency is set by the combination of the main frequency source X and the auxiliary frequency source Y, as shown in the following figure:

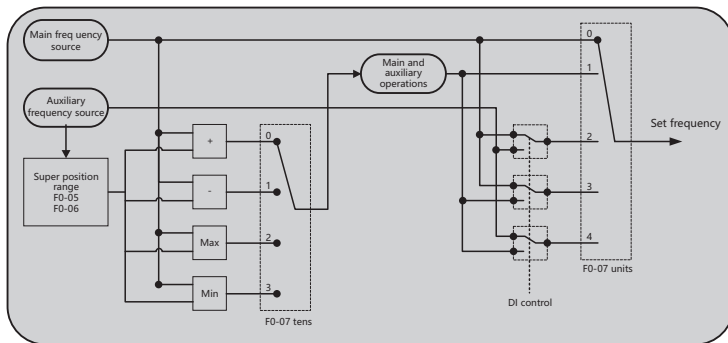

F0-08	Preset frequency	Factory value	50.00Hz	Attribute	○
	Setting range	0.00Hz ~ F0.10 maximum frequency			

When the frequency source is selected as "digital setting", this function code is the initial value for the frequency digital setting of the drive.

F0-09	Direction of operation	Factory value	0	Attribute	○
	Setting range	0	Run in the default direction		
		1	Run in the opposite direction to the default direction		

By changing this function code, the forward direction of the motor can be adjusted without modifying the motor wiring.

Note: After the parameters are initialized, the running direction of the motor will return to its original state. Be careful when it is forbidden to change the motor steering after the system is debugged.

F0-10	Maximum frequency	Factory value	50.00Hz	Attribute	•
	Setting range	50.00Hz~ 500.00Hz			

The actual frequency value 100.0% corresponding to the frequency setting.

F0-11	Upper limiting frequency source	Factory value	0	Attribute	•
	Setting range	0	F0-12 setting		
		1	AI1		
		2	AI2		
		3	AI3		
		4	PULSE setting (HDI)		
5	Communication setting				

When the drive runs to the upper limiting frequency, the drive keeps running at the upper limiting frequency.

F0-12	Upper limiting frequency	Factory value	50.00Hz	Attribute	○
	Setting range	F0-14 (lower limiting frequency) ~ F0-10 (maximum frequency)			
F0-13	Upper limiting frequency offset	Factory value	0.00Hz	Attribute	○
	Setting range	0.00Hz~ F0-10 (maximum frequency)			
F0-14	Lower limit frequency	Factory value	0.00Hz	Attribute	○
	Setting range	0.00Hz ~ F0-12 (upper limiting frequency)			

Upper limiting frequency: When the set frequency of the drive is greater than the upper limiting frequency, the drive runs at the upper limiting frequency.

Upper limiting frequency offset: When the upper limiting frequency source is set to analog or HDI setting, F0-13 is used as the offset of the set value, and the offset frequency is added to the set upper limiting frequency value of F0-11 as the set value of the final upper limiting frequency.

Lower limiting frequency: When the frequency instruction is lower than the lower limiting frequency, the drive can stop, run at the lower limiting frequency or run at zero speed, which can be set by F8-14 (set frequency lower than the lower limiting frequency running mode).

F0-15	Carrier frequency	Factory value	Model determination	Attribute	○
	Setting range	0.5KHz ~ 16.0KHz			
F0-16	Carrier is adjusted with temperature	Factory value	1	Attribute	○
	Setting range	0	No		
		1	Yes		

When the carrier frequency is low, the higher harmonic component of the output current increases, the motor loss increases and the motor temperature rise increases; When the carrier frequency is higher, the motor loss decreases and the motor temperature rise decreases, however the drive loss increases, the drive temperature rise increases and the interference increases.

The carrier frequency is adjusted with temperature, which means that when the drive detects that its radiator temperature is high, it automatically reduces the carrier frequency to reduce the temperature rise of the drive. When the radiator temperature is low, the carrier frequency gradually returns to the set value. This function can reduce the possibility of overheating alarm of the drive.

F0-17	Acceleration time 1	Factory value	Model determination	Attribute	○
	Setting range	0.00s ~ 650.00s (F0-19=2) 0.0s ~ 6500.0s (F0-19=1) 0s ~ 65000s (F0-19=0)			
F0-18	Deceleration time 1	Factory value	Model determination	Attribute	○
	Setting range	0.00s ~ 650.00s (F0-19=2) 0.0s ~ 6500.0s (F0-19=1) 0s ~ 65000s (F0-19=0)			
F0-19	Acceleration and deceleration time unit	Factory value	1	Attribute	⊙
	Setting range	0	1s		
		1	0.1s		
		2	0.01s		

Acceleration time refers to the time required for the drive to accelerate from zero frequency to acceleration and deceleration reference frequency (determined by F0-21); Deceleration time refers to the time required for the drive to decelerate from the acceleration and deceleration reference frequency (determined by F0-21) to zero frequency. As shown in the figure below:

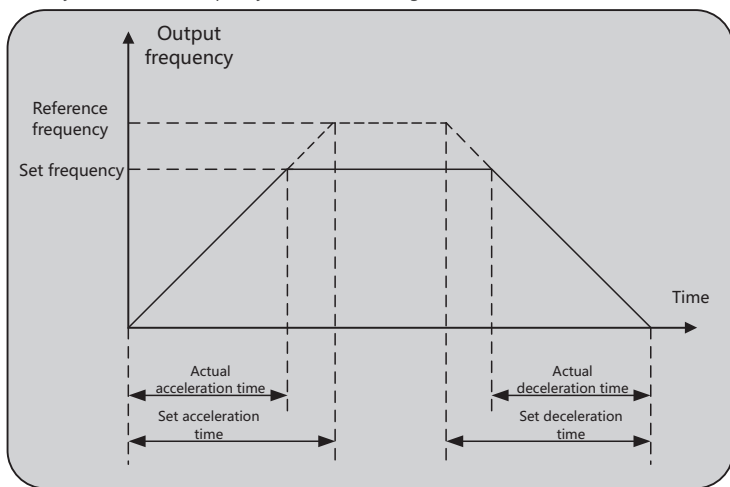

F0-20	Digital setting frequency stop memory	Factory value	0	Attribute	○
	Setting range	0	No memory		
		1	Memory		

This function is only valid when the frequency source is set digitally. "No memory" means that after the drive is shut down, the digital set frequency value is restored to the value of F0-08 (preset frequency), and the frequency correction by keyboard ▲, ▼ keys or UP and DOWN terminals is cleared; "Memory" means that after the drive is shut down, the digital set frequency is kept as the set frequency at the last shutdown, and the frequency correction by keyboard ▲, ▼ keys or UP and DOWN terminals remains effective.

F0-21	Acceleration and deceleration time reference frequency	Factory value	0	Attribute	⊙
	Setting range	0	Maximum frequency (F0-10)		
		1	Set frequency		
		2	100Hz		

Acceleration and deceleration time refers to the acceleration and deceleration time from zero frequency to the frequency set by F0-21.

F0-22	Runtime UP/DOWN benchmark		Factory value	0	Attribute	*
	Setting range	0	Operating frequency			
1		Set frequency				

This parameter is valid only when the frequency source is set digitally. It is used to determine how to correct the set frequency when the keyboard ▲, ▼ keys or UP/DOWN terminals are pressed, that is, whether the target frequency is increased or decreased based on the operating frequency or increased or decreased based on the set frequency.

F0-23	Command source binding frequency source		Factory value	000	Attribute	o	
	Setting range	Units	Operation panel binding frequency source selection				
		0	No binding				
		1	Digital setting				
		2	AI1				
		3	AI2				
		4	AI3				
		5	Pulse setting (HDI)				
		6	Multi-segment instruction				
		7	Simple PLC				
		8	PID				
		9	Communication setting				
		Tens	Terminal binding frequency source selection				
Hundreds	Communication binding frequency source selection						

When the command source is bound to a frequency source, the frequency source set by F0-03~F0-07 will no longer be valid during the validity of the command source. When the command source is switched, the frequency source is also switched with the bound frequency source.

F0-27	Motor selection		Factory value	0	Attribute	*
	Setting range	0	Motor 1			
		1	Motor 2			

The drive supports the application of two motors by time-sharing, and you can set the nameplate parameters of the motors, tune the independent parameters, select different control modes and independently set the parameters related to the running performance for the two motors.

Motor parameter 1 corresponds to functional parameter groups F2 and F3, and motor parameter 2 corresponds to functional parameter group A5.

The user can select the current motor parameter group through this parameter, and can also switch the motor parameters through the digital input terminal X. When the motor selection function is selected for the X terminal function, the set value of this parameter will be invalid, and the X terminal selection shall prevail.

F0-28	Parameter initialization		Factory value	0	Attribute	*	
	Setting range	0	No operation				
		1	Clear record information				
		2	Restore factory parameters, excluding motor parameters				
		4	Backup user parameters				
		5	Restore user parameters				

1. Clear record information

Clear the fault record information, cumulative running time, cumulative power-on time and cumulative power consumption of drive.

2. Restore the factory set value, excluding motor parameters

Most of the functional parameters of the drive are restored to the factory parameters, but the motor

parameters, fault record information, cumulative running time, cumulative power-on time and cumulative power consumption are not restored.

4. Back up the user's current parameters

Back up the parameters set by the current user. Back up the values set for all current function parameters. In order to facilitate customers to recover after parameter adjustment disorder.

5. Restore the user backup parameters

Restore the user parameters backed up before, that is, restore the parameters backed up by setting F0-28 to 4.

12.2 F1 group start-stop control

F1-00	Startup mode		Factory value	0	Attribute	o	
	Setting range	0	Direct startup				
		1	Speed tracking and restart				
		2	Pre-excitation start (AC asynchronous motor)				
3		SVC quick start					

0: direct startup

If the starting time of DC braking is set to 0, the drive starts to run from the starting frequency; If the starting time of DC braking is not 0, DC braking is performed first, and then the operation starts from the starting frequency. It is suitable for occasions with small inertia load and where the motor may run when starting.

1: Speed tracking and restart

The drive first judges the speed and direction of the motor, and then starts with the tracked motor frequency, so as to start the rotating motor smoothly without impact. It is suitable for instantaneous power failure and restart under large inertia load. In order to ensure the performance of speed tracking and restart, it is necessary to set the F2 group parameters of the motor accurately.

2. Pre-excitation start of asynchronous machine

Effective only for asynchronous motors, used to establish magnetic field before the motor runs. Pre-excitation current and pre-excitation time are described in function codes F1-05 and F1-06.

If the pre-excitation time is set to 0, the drive cancels the pre-excitation process and starts from the starting frequency; If the pre-excitation time is not 0, pre-excitation is performed before startup, which can improve the dynamic response of the motor.

3: SVC quick start

It is only suitable for SVC control mode, which can shorten the acceleration time and is suitable for occasions where the inertia of the system is large and quick start is required, however there will be current shock.

F1-01	Speed tracking mode		Factory value	0	Attribute	*	
	Setting range	0	Starting from the stop frequency				
		1	Starting from the power frequency				
		2	Starting from the maximum frequency				
F1-02	Speed tracking speed		Factory value	20	Attribute	*	
	Setting range		1~100				

Speed tracking mode:

0: Track down from the frequency when power outage of the machine, which is selected in general cases.

1: It is used when the power frequency is switched to frequency conversion, and it is used when restarting after power outage for a long time.

2: Track down from the maximum frequency, which is applied to generating load generally.

Speed tracking speed:

The larger the parameter, the faster the tracking speed, but too large a setting may cause the tracking effect to be unreliable.

F1-03	Starting frequency	Factory value	0.00Hz	Attribute	○
	Setting range	0.00Hz ~ 50.00Hz			
F1-04	Holding time of starting frequency	Factory value	0.0s	Attribute	●
	Setting range	0.0s ~ 100.0s			

In order to ensure the motor torque when startup, please set an appropriate starting frequency. In order to fully establish the magnetic flux when the motor is started, it is necessary to keep the starting frequency for a certain time. The starting frequency is not limited by the lower limiting frequency. However, when the set target frequency is less than the starting frequency, the drive is not started and is in a standby state. In the process of forward and reverse switching, the holding time of starting frequency will not work.

F1-05	Starting DC and pre-excitation current	Factory value	50%	Attribute	●
	Setting range	0%~100%			
F1-06	Starting DC and pre-excitation time	Factory value	0.0s	Attribute	●
	Setting range	0.0s~100.0s			
F1-07	Acceleration and deceleration mode	Factory value	0	Attribute	●
	Setting range	0	Linear acceleration and deceleration		
		1	Static S curve		
		2	Dynamic S curve		

Starting DC braking, which is generally used to stop the running motor before starting; Pre-excitation is used to make asynchronous motor establish magnetic field before starting, so as to improve response speed.

Starting DC braking is only effective when the starting mode is direct starting. At this time, the drive will perform DC braking according to the set starting DC braking current, and then start running after the starting DC braking time. If the DC braking time is set to 0, it will be started directly without DC braking. The greater the DC braking current, the greater the braking force.

If the startup mode is pre-excitation startup of asynchronous machine, the drive first establishes the magnetic field in advance according to the set pre-excitation current, and then starts running after the set pre-excitation time. If the pre-excitation time is set to 0, it will be started directly without pre-excitation process.

Starting DC braking current/pre-excitation current has two situations relative to the base value.

1. When the rated current of the motor is less than or equal to 80% of the rated current of the drive, it is a percentage base value relative to the rated current of the motor.
2. When the rated current of the motor is greater than 80% of the rated current of the drive, it is a percentage base value relative to 80% of the rated current of the drive.

Acceleration and deceleration mode:

0: linear acceleration and deceleration

The output frequency increases or decreases in a linear manner.

1: Static S curve

When the target frequency is fixed, the output frequency increases or decreases according to the S curve. It is suitable for use in places that require gentle start or stop, such as elevators and conveyor belts.

2: Dynamic S curve

When the target frequency changes dynamically in real time, the output frequency increases or decreases in real time according to the S curve. It is suitable for occasions with high comfort requirements and quick real-time response.

F1-08	Time proportion at the beginning of S curve	Factory value	30.0%	Attribute	●
	Setting range	0.0% ~ (100.0%-F1-09)			
F1-09	Time proportion at the end of S curve	Factory value	30.0%	Attribute	●
	Setting range	0.0% ~ (100.0%-F1-08)			

The two function codes shall meet the following requirements: F1-08 + F1-09 ≤ 100.0%.

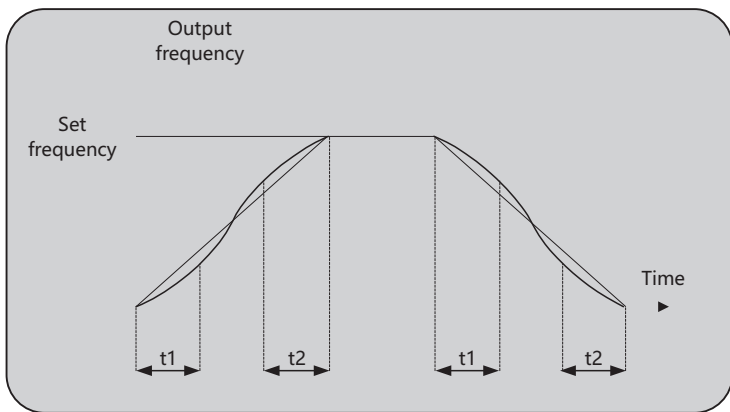

In the figure, t1 is the time period parameter defined by parameter F1-08, during which the slope of output frequency change gradually increases. T2 is the time period defined by parameter F1-09, during which the slope of output frequency changes gradually to 0. During the time between t1 and t2, the slope of output frequency change is fixed, that is, linear acceleration and deceleration is performed in this interval.

F1-10	Stop mode	Factory value	0	Attribute	○
	Setting range	0	Stop by deceleration		
		1	Free stop		

- 0: Stop by deceleration After the stop command takes effect, the drive reduces the output frequency according to the deceleration time, and stops after the frequency drops to 0.
- 1: Free stop After the stop command takes effect, the drive immediately terminates the output, and the motor stops freely according to the mechanical inertia.

F1-11	Starting frequency of stop DC braking	Factory value	0.00Hz	Attribute	○
	Setting range	0.00Hz~ maximum frequency			
F1-12	Waiting time for stop DC braking	Factory value	0.0s	Attribute	○
	Setting range	0.0s ~ 100.0s			
F1-13	Stop DC braking current	Factory value	50%	Attribute	○
	Setting range	0% ~ 100%			
F1-14	Stop DC braking time	Factory value	0.0s	Attribute	○
	Setting range	0.0s ~ 100.0s			

Starting frequency of stop DC braking: In the process of stop by deceleration, when the operating frequency is reduced to this frequency, the DC braking process is started.

Waiting time of stop DC braking: After the operating frequency is reduced to the starting frequency of DC braking, the drive stops outputting for a period of time before starting DC braking. It is used to prevent overcurrent and other faults that may be caused by starting DC braking at higher speed.

Stop DC braking current: Stop DC braking current has two situations relative to the basic value.

1. When the rated current of the motor is less than or equal to 80% of the rated current of the drive, it is a percentage base value relative to the rated current of the motor.
2. When the rated current of the motor is greater than 80% of the rated current of the drive, it is a percentage base value relative to 80% of the rated current of the drive.

Stop DC braking time: Time for DC braking amount to be maintained. If this value is 0, the DC braking process is cancelled.

F1-15	Brake utilization rate	Factory value	100%	Attribute	○
	Setting range	0% ~ 100%			

Only valid for drives with built-in braking units. It is used to adjust the duty cycle of the moving unit. If the braking utilization rate is high, the braking unit will have a high action duty cycle and a strong braking effect, but the bus voltage of the drive fluctuates greatly during braking.

12.3 F2 group motor parameters

F2-00	Motor type	Factory value	0	Attribute	●
	Setting range	0	Normal asynchronous motor		
		1	Drive asynchronous motor		
F2-01	Rated power of motor	Factory value	Model determination	Attribute	●
	Setting range	0.1kW ~ 1000.0kW			
F2-02	Rated voltage of motor	Factory value	Model determination	Attribute	●
	Setting range	1V ~ 2000V			
F2-03	Rated current of motor	Factory value	Model determination	Attribute	●
	Setting range	0.01A ~ 655.35A (drive power ≤ 55kW) 0.1A ~ 6553.5A (drive power > 55kW)			
F2-04	Rated frequency of motor	Factory value	Model determination	Attribute	●
	Setting range	0.01Hz~ maximum frequency			
F2-05	Rated speed of motor	Factory value	Model determination	Attribute	●
	Setting range	1rpm ~ 6553rpm			

In order to make the drive achieve better control effect, please set the above parameters accurately according to the motor nameplate.

F2-06	Stator resistance of asynchronous motor	Factory value	Tuning parameter	Attribute	●
	Setting range	0.001Ω ~ 65.535Ω (drive power ≤ 55kW) 0.0001Ω ~ 6.5535Ω (drive power > 55kW)			
F2-07	Rotor resistance of asynchronous motor	Factory value	Tuning parameter	Attribute	●
	Setting range	0.001Ω ~ 65.535Ω (drive power ≤ 55kW) 0.0001Ω ~ 6.5535Ω (drive power > 55kW)			
F2-08	Leakage inductance of asynchronous motor	Factory value	Tuning parameter	Attribute	●
	Setting range	0.01mH ~ 655.35mH (drive power ≤ 55kW) 0.001mH ~ 65.535mH (drive power > 55kW)			
F2-09	Mutual inductance of asynchronous motor	Factory value	Tuning parameter	Attribute	●
	Setting range	0.1mH ~ 6553.5mH (drive power ≤ 55kW) 0.01mH ~ 655.35mH (drive power > 55kW)			
F2-10	No-load current of asynchronous motor	Factory value	Tuning parameter	Attribute	●
	Setting range	0.01A~F2-03 (drive power ≤ 55kW) 0.1A~F2-03 (drive power > 55kW)			

The above are the tuning parameters of asynchronous motor, which are generally not on the nameplate of the motor and need to be obtained by automatic tuning of the drive. Where, only three parameters F2-06 ~ F2-08 can be obtained by "parameter tuning of static part of asynchronous motor", while all the above parameters can be obtained by "dynamic complete tuning of asynchronous motor" and "static complete tuning of asynchronous motor".

When changing the rated power or voltage of the motor, the drive will automatically modify the above parameters and restore them to the default parameters of the commonly used standard motor.

F2-37	Tuning selection	Factory value	0	Attribute	●
	Setting range	0	No operation		
		1	Static part parameter tuning of asynchronous machine		
		2	Dynamic complete tuning of asynchronous machine		
	3	Static complete tuning of asynchronous machine			

Before parameter self-learning, motor type and nameplate parameters F2-00~F2-05 shall be set correctly, and encoder type (Fd-01) and pulse number (Fd-00) shall be set additionally for closed-loop vector control.

Description of tuning action: Set the nameplate parameters and self-learning type of the motor, and then press the RUN key to tune the drive.

0: No operation:

i.e., tuning is disabled.

1: Static part parameter tuning of asynchronous machine

It is suitable for the occasions where synchronous motors are used and the large inertia load is not easy to be disengaged, causing failure of rotary tuning.

2: Dynamic complete tuning of asynchronous machine

In the process of dynamic tuning, the drive performs static tuning first, and then accelerates to 80% of the rated frequency of the motor according to the acceleration time. After maintaining for a period of time, it stops by deceleration according to the deceleration time and ends the tuning.

3: Static complete tuning of asynchronous machine

It is suitable for self-learning of motor parameters when the motor is in static state without encoder (at this time, the motor may still have slight jitter, so pay attention to safety)

12.4 F3 group vector control parameters

F3-00	Speed/Torque control selection	Factory value	0	Attribute	*
	Setting range	0	Speed control		
	1	Torque control			

Speed control/Torque control switching (Xx function selection 46). These two terminals shall be used together with F3-00 to realize the switching of speed and torque control. When the speed control/torque control switching terminal is invalid, it is the control mode selected by F3-00; If the speed control/torque control switch is valid, it is the control mode not selected by F3-00.

When the torque control prohibited terminal (Xx function selection 29) is valid, the drive is fixed as the speed control mode.

F3-01	Speed loop proportional gain 1	Factory value	30	Attribute	o
	Setting range	1 ~ 100			
F3-02	Speed loop integration time 1	Factory value	0.50s	Attribute	o
	Setting range	0.01s ~ 10.00s			
F3-03	Switching frequency 1	Factory value	5.00Hz	Attribute	o
	Setting range	0.00Hz ~ F3-06			
F3-04	Speed loop proportional gain 2	Factory value	20	Attribute	o
	Setting range	1 ~ 100			
F3-05	Speed loop integration time 2	Factory value	1.00s	Attribute	o
	Setting range	0.01s ~ 10.00s			
F3-06	Switching frequency 2	Factory value	10.00Hz	Attribute	o
	Setting range	F3-03 ~ maximum frequency			

By setting the proportional gain and integration time of the speed loop, the speed dynamic response characteristics of vector control can be adjusted. Increasing proportional gain and reducing integration time can speed up the dynamic response of speed loop. However, too large proportional gain or too short integration time may cause system oscillation.

In the vector control mode, the corresponding speed loop PI parameters can be selected according to the operating frequency. When the operating frequency is less than or equal to the switching frequency 1, the speed loop selects the first group of PI parameters (proportional gain 1 and integration time 1); When the operating frequency is greater than or equal to switching frequency 2, the speed loop selects the second group of PI parameters (proportional gain 2, integration time 2); When the operating frequency is between switching frequency 1 and switching frequency 2, the parameter is the result of linear conversion of two groups of parameters, as shown in the following figure:

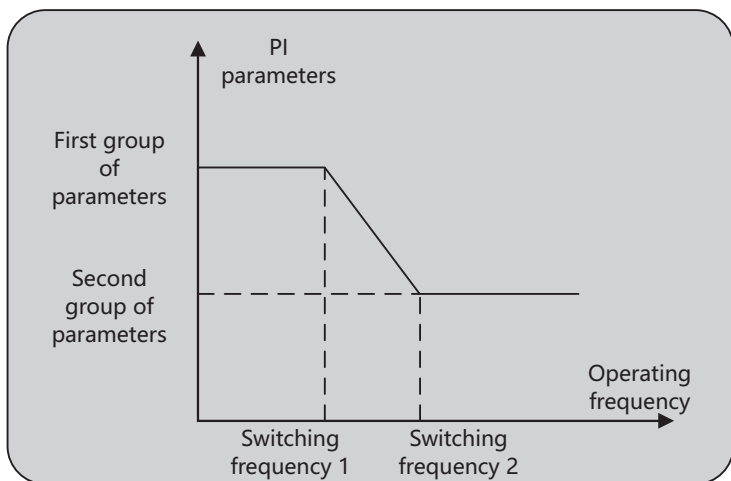

F3-07	Vector control slip gain	Factory value	100%	Attribute	○
	Setting range	50% ~ 200%			

Sensorless vector control mode, this parameter is used to adjust the steady-state accuracy of the motor: When the on-load speed of the motor is low, this parameter will be increased, otherwise it will be reduced; Flux sensor vector control mode, this parameter can adjust the output current of the drive under the same load.

F3-08	SVC speed feedback filtering time	Factory value	0.015s	Attribute	○
	Setting range	0.000s ~ 0.1000s			

This parameter is only valid in SVC control mode. Increasing parameters can improve the stability of the motor, but with slow dynamic response; Reducing parameters can lead to fast dynamic response, but it may cause motor oscillation.

F3-10	Upper limit source of torque in speed control	Factory value	0	Attribute	●	
	Setting range	0	F3-11 setting			
		1	AI1			
		2	AI2			
		3	AI3			
		4	HDI pulse			
		5	Communication setting			
		6	MIN(AI1,AI2)			
7	MAX(AI1,AI2)					
F3-11	Digital setting of upper limit of torque	Factory value	150.0%	Attribute	○	
	Setting range	0.0% ~ 200.0%				

F3-12	Upper limit source of torque in speed control mode (power generation)		Factory value	0	Attribute	⊙
	Setting range	0	F3-10 setting (no distinction between motoring and power generation)			
		1	AI1			
		2	AI2			
		3	AI3			
		4	HDI pulse			
		5	Communication setting			
		6	MIN(AI1,AI2)			
		7	MAX(AI1,AI2)			
8	Parameter F3-13 setting					
F3-13	Digital setting of upper limit of torque (power generation)		Factory value	150.0%	Attribute	○
	Setting range		0.0% ~ 200.0%			

The above parameters are used to set the upper limit value of output torque in vector control speed mode. The upper limit of torque can be set by digital setting, AIx analog, HDI pulse and communication. When set by AI analog, HDI pulse and communication, it 100% corresponds to F3-11, and F3-11 100% corresponds to the rated output current of the drive.

Example: When F3-10 = 1, the upper limit source of torque is AI1; F3-11=150.0%. When AI1 inputs 50%, the upper limit of the set torque at this time is 50% X 150.0% =75.0% of the rated current.

Torque limit is divided into motoring state and power generation state. In the motoring state, the upper limit of torque is determined by F3-10 and F3-11; In the power generation state, the upper limit of torque is determined by F3-12 and F3-13. If F3-12 is set to 0, no distinction is made between motoring and power generation, and the upper limit of torque is determined by F3-10 and F3-11.

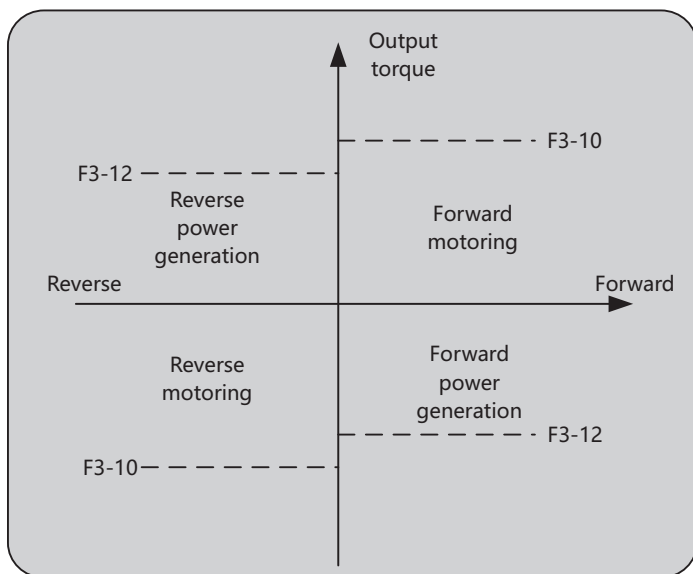

F3-14	Excitation regulation proportional gain	Factory value	2000	Attribute	○
	Setting range	0 ~ 60000			
F3-15	Excitation regulation integral gain	Factory value	1300	Attribute	○
	Setting range	0 ~ 60000			
F3-16	Torque regulation proportional gain	Factory value	2000	Attribute	○
	Setting range	0 ~ 60000			
F3-17	Torque regulation integral gain	Factory value	1300	Attribute	○
	Setting range	0 ~ 60000			

Current loop PI adjustment parameters in vector control mode: such parameters will be automatically obtained after asynchronous machine tuning, which generally do not need to be modified. Note: The integral regulator of the current loop does not use the integration time as the dimension, but directly sets the integration gain.

If the PI gain of the current loop is set too large, it may cause the whole control loop to oscillate, so when the current oscillation or torque fluctuation is large, the PI proportional gain or integral gain here can be reduced manually.

F3-23	Power generation limit enabled	Factory value	0	Attribute	○
	Setting range	0	Invalid		
		1	Valid		
F3-24	Upper limit of power generation	Factory value	Model determination	Attribute	○
	Setting range	0.0% ~ 200.0%			

In the vector control speed mode, the power limiting function can effectively reduce the bus voltage overshoot during motor braking and avoid the occurrence of overvoltage fault. The upper limit of power generation F3-24 is the percentage of the rated power of the motor. When overvoltage still occurs after the power generation limit function is enabled, please adjust F3-24 downward.

The part above F3 group parameters are related parameters of vector speed mode, and those below are related parameters of vector torque mode.

F3-25	Upper limit source of torque in torque control	Factory value	0	Attribute	⊙
	Setting range	0	Digital setting (F3-27)		
		1	AI1		
		2	AI2		
		3	AI3		
		4	HDI pulse		
		5	Communication setting		
		6	MIN(AI1,AI2)		
7	MAX(AI1,AI2)				
F3-27	Upper limit of torque in torque control	Factory value	150.0%	Attribute	○
	Setting range	-200.0% ~ 200.0%			

Torque setting adopts relative value, 100.0% corresponding to the rated torque of the motor. The setting range is -200.0%~200.0%, indicating that the maximum torque of the drive is twice the rated torque of the drive. When the torque is set as positive, the drive runs forward; When the torque is set as negative, the drive runs in reverse.

F3-29	Maximum forward frequency of torque control	Factory value	50.00Hz	Attribute	○
	Setting range	0.00 ~ maximum frequency			
F3-30	Maximum reverse frequency of torque control	Factory value	50.00Hz	Attribute	○
	Setting range	0.00 ~ maximum frequency			

When the drive torque is controlled, if the load torque is less than the output torque of motor, the motor speed will continue to rise. In order to prevent accidents such as runaway in the mechanical system, the maximum speed of motor during torque control must be limited. During torque control, the acceleration and deceleration time of the upper frequency limit is set in F8-07 (acceleration time 4)/F8-08 (deceleration time 4), which is 0.0s by default. It is used to set the forward or reverse maximum operating frequency of the drive under torque control mode. If a dynamic and continuous change in the maximum frequency of torque control is required, it can be achieved by controlling the upper limiting frequency.

F3-31	Filtering time for torque rise	Factory value	0.00s	Attribute	○
	Setting range	0.00s ~ 650.00s			
F3-32	Filtering time for torque drop	Factory value	0.00s	Attribute	○
	Setting range	0.00s ~ 650.00s			

In the torque control mode, the difference between the motor output torque and the load torque determines the speed change rate of the motor and the load, therefore, the motor speed may change rapidly, causing problems such as excessive noise or mechanical stress. By setting the torque control acceleration and deceleration time, the motor speed can be changed smoothly.

For example, two motors are hard-wired to drive the same load. In order to ensure the uniform distribution of the load, one drive is set as the master in speed control mode, while the other drive is set as the slave in torque control mode. The actual output torque of the master is used as the torque instruction of the slave. At this time, the torque of the slave needs to follow the master quickly, so the acceleration and deceleration time of the slave's torque control is 0.00 s.

12.5 F4 group VF control parameters

F4-00	VF curve setting	Factory value	0	Attribute	●
	Setting range	0	Linear V/F		
1		Multipoint V/F			
2~9		Reserved			
10		VF complete separation mode			
11		VF semi-separation mode			

0: Linear V/F

It is suitable for ordinary constant torque load.

1: multipoint V/F

It is suitable for special loads such as dehydrators and centrifuges. At this time, by setting F4-03 ~ F4-08 parameters, any V/F curve can be obtained.

10: VF complete separation mode

At this time, the output frequency and output voltage of the drive are independent of each other, and the output frequency is determined by the frequency source, while the output voltage is determined by F4-13 (VF separated voltage source). V/F complete separation mode is generally used in occasions such as induction heating, drive power supply and torque motor control.

11: VF semi-separation mode

In this case, V and F are proportional, but the proportional relationship can be set by the voltage source F4-13, and the relationship between V and F is also related to the rated voltage and rated frequency of the motor in F2 group. Assuming that the input of the voltage source is X (X is a value of 0~100%), the relationship between the output voltage V of the drive and the frequency F is: $V/F = 2 * X *$ (rated voltage of the motor) / (rated frequency of the motor)

F4-01	Torque boost	Factory value	Model determination	Attribute	○
	Setting range	0.0% (automatic torque boost) 0.1% ~ 30.0%			
F4-02	Torque boost cutoff frequency	Factory value	50.00Hz	Attribute	●
	Setting range	0.00Hz ~ maximum frequency			

Torque boost is used to compensate the low-frequency torque characteristics of V/F control. If the torque boost setting is too large, it will easily lead to overcurrent or overload failure, and the motor will easily overheat; If the torque boost setting is too small, it will easily lead to motor stall, therefore the torque boost parameters need to be adjusted according to the actual load situation.

When the torque boost is set to 0.0%, the drive will automatically calculate the required torque boost value according to the parameters such as motor stator resistance. In this case, if conditions permit, please tune the parameters of the motor to obtain accurate motor parameters.

Torque boost torque cutoff frequency: At this frequency, the torque boost amount is calculated linearly according to the operating frequency and cutoff frequency, and if this set frequency is exceeded, the torque boost will not work, as shown in the following figure:

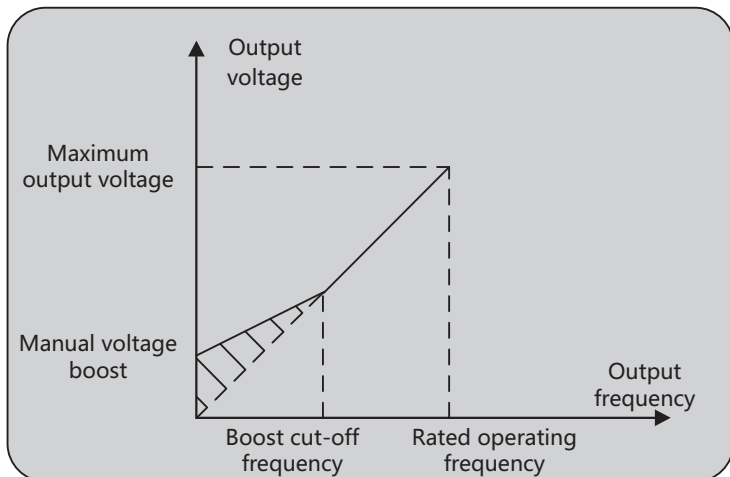

F4-03	Multipoint VF frequency point F1	Factory value	0.00Hz	Attribute	•
	Setting range	0.00 Hz ~ F4.05			
F4-04	Multipoint VF voltage point V1	Factory value	0.0%	Attribute	•
	Setting range	0.0% ~ 100.0%			
F4-05	Multipoint VF frequency point F2	Factory value	0.00Hz	Attribute	•
	Setting range	F4-03 ~ F4-07			
F4-06	Multipoint VF voltage point V2	Factory value	0.0%	Attribute	•
	Setting range	0.0% ~ 100.0%			
F4-07	Multipoint VF frequency point F3	Factory value	0.00Hz	Attribute	•
	Setting range	F4-05 ~ rated frequency of motor			
F4-08	Multipoint VF voltage point V3	Factory value	0.0%	Attribute	•
	Setting range	0.0% ~ 100.0%			

The curve of multipoint V/F shall be set according to the load characteristics of the motor. It shall be noted that the relationship between three voltage points and frequency points must meet the following requirement: $V1 < V2 < V3$, $F1 < F2 < F3$. If the voltage is set too high at low frequency, it may cause overheating or even burn out of the motor, or overcurrent or overcurrent protection of the drive.

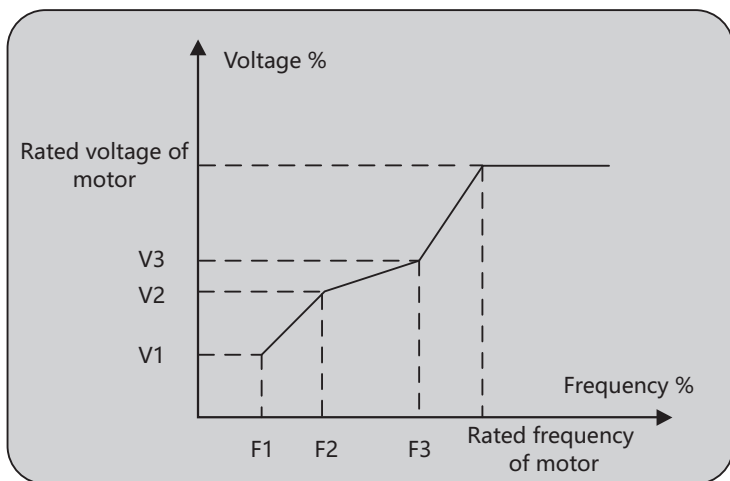

F4-09	VF slip compensation gain	Factory value	0.0%	Attribute	○
	Setting range	0% ~ 200.0%			

VF slip compensation can compensate the motor speed deviation of asynchronous motor generated when the load increases, so that the motor speed can basically remain stable when the load changes.

The VF slip compensation gain is set to 100.0%, which means that the slip compensated when the motor is loaded with rated load is the rated slip of the motor, while the rated slip of the motor is obtained through automatic calculation of rated frequency and rated speed of motor.

When adjusting the VF slip compensation gain, the principle is that the motor speed is basically the same as the target speed generally under rated load. When the motor speed is different from the target value, it is necessary to fine-tune the gain.

F4-10	VF overexcitation gain	Factory value	64	Attribute	○
	Setting range	0 ~ 200			

In the process of drive deceleration, over-excitation control can suppress the rise of bus voltage and avoid overvoltage fault. The greater the over-excitation gain, the stronger the suppression effect.

It is necessary to improve the over-excitation gain when the drive is prone to overvoltage alarm during deceleration. However, the over-excitation gain is too large, which will easily lead to the increase of output current and the motor heating.

When the inertia is very small, and the voltage will not rise during the motor deceleration, it is suggested to set the over-excitation gain to 0; In the case of braking resistor, it is also recommended that the over-excitation gain be set to 0.

F4-11	VF oscillation suppression gain	Factory value	40	Attribute	○
	Setting range	0 ~ 100			

In VF control mode, if the motor oscillates obviously, the gain can be increased appropriately. The greater the gain, the more obvious the suppression of oscillation will be. Try to set it as small as possible under the premise of effectively suppressing oscillation, so as not to adversely affect VF operation. When the motor has no oscillation, please set this gain to 0.

When using the oscillation suppression function, the rated current and no-load current parameters of the motor are required to be accurate, otherwise the VF oscillation suppression effect is not good.

F4-13	Voltage source of VF separation		Factory value	0	Attribute	o
	Setting range	0	Digital setting (F4-14)			
		1	AI1			
		2	AI2			
		3	AI3			
		4	Pulse setting HDI			
		5	Multi-segment instruction			
		6	Simple PLC			
		7	PID			
8	Communication setting					
F4-14	Voltage digital setting of VF separation		Factory value	0V	Attribute	o
	Setting range		0v ~ Rated voltage of motor			

VF separation is generally used in occasions such as induction heating, drive power supply and torque motor control.

When selecting VF separation control, the output voltage can be set by function code F4-14, or it can come from analog, pulse setting HDI, multi-segment instruction, simple PLC, PID or communication setting. When non-digital setting is used, 100% of each setting corresponds to the rated voltage of the motor. When the percentage of output setting such as analog is negative, the set absolute value is taken as the effective setting value.

0: Digital setting

The voltage is directly set by F4-14.

1: Ai1

2: Ai2

3: Ai3

The voltage is determined by the analog input terminal.

4. Pulse setting HDI

Voltage setting is given by terminal pulse. Pulse set signal specifications: voltage range 9V ~ 30V, frequency range 0 kHz ~ 100 kHz.

5. Multi-segment instruction

When the voltage source is multi-segment instruction, FA group parameters shall be set to determine the set voltage. The 100.0% given by the multi-segment instruction of FA group parameters refers to the percentage relative to the rated voltage of the motor.

6. Simple PLC

When the voltage source is simple PLC, FA group parameters need to be set to determine the set output voltage.

7. PID

Output voltage is generated according to PID closed loop. See the introduction of F9 group PID for details.

8. Communication setting

It refers to the voltage set by the upper computer through communication.

VF separation voltage source selection is similar to frequency source selection. See the introduction of F0-03 main frequency source selection. Where, 100.0% of the corresponding settings for various selections refers to the rated voltage of the motor (taking the absolute value of the corresponding settings).

F4-15	Voltage rise time of VF separation		Factory value	0.0s	Attribute	o
	Setting range		0.0s ~ 1000.0s			
F4-16	Voltage drop time of VF separation		Factory value	0.0s	Attribute	o
	Setting range		0.0s ~ 1000.0s			

Same as the frequency acceleration and deceleration time, the voltage rise (drop) time refers to the time required to accelerate (decelerate) from zero voltage (motor rated voltage) to the motor rated voltage (zero voltage), not the time to accelerate (decelerate) from zero voltage (target voltage) to the target voltage (zero voltage).

F4-17	Selection of VF separation stop mode		Factory value	0	Attribute	○
	Setting range	0	0: Frequency/voltage separately decreases to 0			
		1	1: Frequency decreases again after the voltage decreases to 0			

0: Frequency/voltage separately decreases to 0

When the drive stops, the frequency and voltage decrease according to their respective acceleration and deceleration times.

1: Frequency decreases again after the voltage decreases to 0

The output voltage is first reduced to 0V according to the voltage drop time, and then the frequency is reduced to 0Hz according to the deceleration time

F4-18	Overcurrent stall action current		Factory value	150%	Attribute	⊙
	Setting range		50% ~ 200.0%			
F4-19	Overcurrent stall enabled		Factory value	1	Attribute	⊙
	Setting range	0	Invalid			
		1	Valid			
F4-20	Overcurrent stall suppression gain		Factory value	20	Attribute	○
	Setting range		0 ~ 100			
F4-21	Current compensation coefficient of double-speed overcurrent stall action		Factory value	50%	Attribute	⊙
	Setting range		50% ~ 200%			

Overcurrent stall enabled:

Overcurrent stall action current:

Overcurrent stall enable function: When the output current of the drive reaches the overcurrent stall action current, the drive starts to adjust the output frequency. If it is in the motoring state at this time, the output frequency will start to drop and adjust; If it is in the power generation state, the output frequency will start to rise and adjust. In this case, the acceleration and deceleration time will be automatically lengthened. If the actual acceleration and deceleration time cannot meet the requirements, the overcurrent stall action current can be appropriately increased.

Overcurrent stall suppression gain:

When the overcurrent stall occurs, the drive adjusts the output frequency to PI, and the P proportional gain and integration time are uniformly adjusted by the overcurrent stall suppression gain parameter.

Current compensation coefficient of double-speed overcurrent stall action:

In the high frequency region, the motor drive current is small, and the speed of the motor drops greatly compared with the same stall current at the rated frequency. In order to improve the operating characteristics of the motor, the stall action current above the rated frequency can be reduced. This method has a good effect on the acceleration performance in some occasions where there are centrifuges with high operating frequency, which require several times of flux weakening and large load inertia. Overcurrent stall action current exceeding rated frequency = $(f_s/f_n) * k * \text{LimitCur}$; where, f_s is the operating frequency, f_n is the rated frequency of the motor, k is F4-21 "compensation coefficient of double overcurrent stall action current", and LimitCur is F4-18 "overcurrent stall action current".

When F4-21 is set to 50%, it means that the compensation coefficient of double overcurrent stall action does not work.

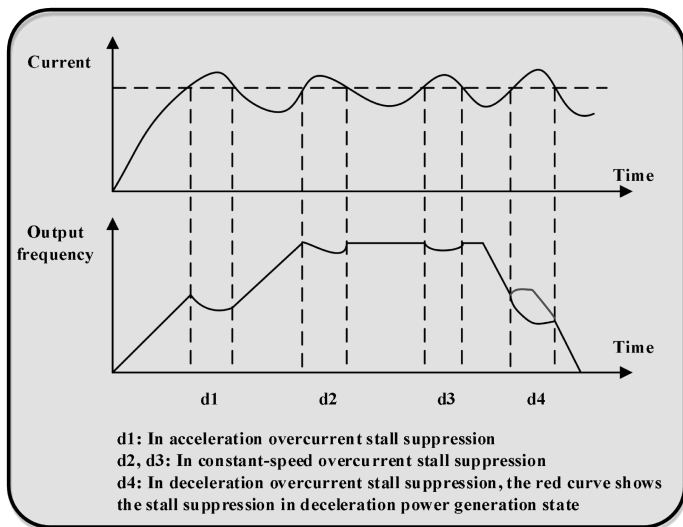

F4-22	Overvoltage stall action voltage	Factory value	Model determination	Attribute	⊙
	Setting range	380V model: 650.0V~800.0V 220V model: 320.0V~800.0V			
F4-23	Overvoltage stall enabled	Factory value	1	Attribute	⊙
	Setting range	0 1	Invalid Valid		
F4-24	Overvoltage stall suppression frequency gain	Factory value	30	Attribute	○
	Setting range	0 ~ 100			
F4-25	Overvoltage stall suppression voltage gain	Factory value	30	Attribute	○
	Setting range	0 ~ 100			
F4-26	Maximum rise frequency of overvoltage stall	Factory value	5Hz	Attribute	⊙
	Setting range	0 ~ 50Hz			

When the bus voltage reaches the set value of overvoltage stall action voltage, the actual motor speed is greater than the motor speed corresponding to the output frequency of the drive, and the motor is in a power generation state. In order to protect the system safety and avoid tripping protection, the drive starts the overvoltage stall protection function and increases the output frequency, so the actual deceleration time will be automatically lengthened. If the actual deceleration time cannot meet the system requirements, the over-excitation gain can be appropriately increased or addition braking resistor can be installed.

During the overvoltage stall action, the drive simultaneously adjusts the output frequency and output voltage through PI control, and the overvoltage stall suppression frequency gain is used to modify the proportional gain and integration time of the frequency adjustment PI; Overvoltage stall suppression voltage gain is used to modify the proportional gain and integration time of voltage adjustment PI.

The maximum rise frequency of overvoltage stall is used to limit the maximum rise frequency during frequency adjustment.

Note: The bus voltage limit function in vector control mode also needs to turn on F4-23 overvoltage stall enable function and set F4-22 limit voltage point.

12.6 F5 group input terminal

NVF7 Series Drive comes standard with five multi-function digital input terminals (where HDI can be used as high-speed pulse input terminal) and 2 analog input terminals. The following functions can be set for each input terminal.

Set value	Function	Notes
0	No function	Unused terminals can be set to "no function" to prevent misoperation.
1	Forward running FWD	The forward rotation and reverse rotation of the drive are controlled by external terminals.
2	Reverse running REV	
3	Three-wire running control	It is used for the running control in control terminal mode. Refer to the description of function code F5-11 ("terminal command mode").
4	Forward jog	It is used for jog running control in control terminal mode, and the jog operating frequency and acceleration and deceleration time are defined in F8-00 ~ F8-02.
5	Reverse jog	
6	Terminal UP	When the frequency source is set to digital setting and the frequency is modified, it is used as an increasing and decreasing instruction.
7	Terminal DOWN	
8	Free stop	Free running stop is realized by control terminal, which has the same function as defined in F1-10.
9	Fault reset	The terminal is used for fault reset function. Same as the fault reset function of the STOP key on the keyboard, this function can realize remote fault reset.
10	Running pause	When the drive stops by deceleration, all operating parameters are memorized (such as PLC parameters and PID parameters) when the terminal is valid; After the terminal is invalid, the drive will resume its previously memorized running state.
11	External fault normally on input	Through this terminal, the fault signal of external equipment can be input, which is convenient for the drive to monitor the fault of external equipment. After receiving the fault signal of external equipment, the drive displays "E.EF", that is, the external equipment fault alarm.
12	Multi-segment instruction terminal 1	16-speed setting can be realized through 16 states of these four terminals.
13	Multi-segment instruction terminal 2	
14	Multi-segment instruction terminal 3	
15	Multi-segment instruction terminal 4	
16	Acceleration and deceleration time selection terminal 1	Through the 4 states of this terminal, 4 types of acceleration and deceleration time can be selected.
17	Acceleration and deceleration time selection terminal 2	
18	Frequency command switching	It is used to switch between different frequency sources. See the description of function code F0-07 for details. When it is set to switch between two frequency sources as the target frequency, frequency source switching can be realized through this terminal.

Set value	Function	Notes
19	UP/DOWN setting cleared (terminal, keyboard)	When the main frequency is set by digital setting, terminal may select this function to clear the frequency value changed by the UP and DOWN keys on the keyboard or by the multi-function terminals 6(UP) and 7(DOWN), so that the set frequency can be restored to F0-08 setting.
20	Control command switch terminal 1	Through this terminal, the control command source can be switched from terminal control or communication control to panel control.
21	Acceleration and deceleration disabled	Maintain the current output frequency (except the stop command).
22	PID pause	The drive maintains the current output frequency and pauses PID adjustment.
23	Simple PLC state reset	Restore the drive to the initial state of simple PLC.
24	Counter input	Input terminal of counting pulse.
25	Counter reset	Clear the state of the counter.
26	Length count input	Input terminal for length counting.
27	Length reset	Clear the length.
28	Torque control disabled	The drive prohibits torque control mode and automatically enters speed control mode.
29	Pulse frequency input (valid only for HDI)	Set HDI as a high-speed pulse input terminal.
30	Reserved	Reserved.
31	Immediate DC braking	The drive directly switches to the DC braking state.
32	External fault normally off input	Through this terminal, the fault signal of external equipment can be input, which is convenient for the drive to monitor the fault of external equipment. After receiving the fault signal of external equipment, the drive displays "E.EF", that is, the external equipment fault alarm.
33	Frequency modification enabled	Through this terminal, it can be controlled whether the frequency modification of the drive is valid. When the terminal state is valid, the frequency of the drive can be modified, otherwise the frequency will not change. When this function is not set, it does not affect the setting of main frequency and auxiliary frequency.
34	PID action direction reversed	When this terminal is valid, the PID function is reversed to that set in F9-03.
35	External stop terminal 1	Control the drive to stop properly, which is only valid under panel control.
36	Control command switch terminal 2	It is used to switch between terminal control and communication control.
37	PID integration pause	The integral adjustment function of PID is paused. In this case, the proportional adjustment and differential adjustment are still valid, and the integral attribute of PID is required to be F9-25=x1.
38	Main frequency and preset frequency switching	When this terminal is valid, the frequency source X is replaced by the preset frequency (F0-08).
39	Auxiliary frequency and preset frequency switching	When this terminal is valid, the frequency source Y is replaced by the preset frequency (F0-08).
40	Motor selection terminal	Select motor 1 when the terminal is invalid, and motor 2 when the terminal is valid.
41	Reserved	Reserved.
42	PID parameter switching	When F9-18=1 (PID parameters are switched by X terminal) and the terminal state is 0, the PID parameters are F9-05 ~ F9-07; When the terminal state is 1, the PID parameters are F9-15~F9-17.
43	User-defined fault 1	When user-defined fault terminals 1 and 2 are valid, the drive will alarm E.US1 and E.US2 respectively, and the drive will handle the fault according to the parameters selected by FE-49.
44	User-defined fault 2	

Set value	Function	Notes
45	Speed control/torque control switching	It is used to switch between speed control mode and torque control mode.
46	Emergency stop	The drive is in the fastest deceleration state, at which the deceleration current and voltage are in the maximum limit state.
47	External stop terminal 2	When the terminal state is valid, the drive enters the stop by deceleration state, and the deceleration time is deceleration time 4. It is valid in all control modes.
48	Deceleration DC braking	The drive decelerates to the starting frequency of DC braking and enters the DC braking deceleration state.
49	Current running time is cleared	Clear running time of drive: it is used for the function of timed operation (F8-42).
50	Two-wire/three-wire switching	It is used to switch between two-wire control method and three-wire control method (that is, two-wire 1 is switched to three-wire 1, and two-wire 2 is switched to three-wire 2).
51	Reverse frequency disabling	Reverse frequency disabling: the drive runs at 0 Hz when it is reversed.

The 16-segment operating frequency can be set by the four multi-segment command terminals maximally, which can be selected through the arrangement and combination of four X terminals. Multi-segment frequency setting can also be performed with less than 4X terminals. For the missing set bits, it is calculated as 0, as shown in the following table:

K4	K3	K2	K1	Instruction setting	Corresponding parameter
0	0	0	0	Multi-segment frequency 0	FA-00
0	0	0	1	Multi-segment frequency 1	FA-01
0	0	1	0	Multi-segment frequency 2	FA-02
0	0	1	1	Multi-segment frequency 3	FA-03
0	1	0	0	Multi-segment frequency 4	FA-04
0	1	0	1	Multi-segment frequency 5	FA-05
0	1	1	0	Multi-segment frequency 6	FA-06
0	1	1	1	Multi-segment frequency 7	FA-07
1	0	0	0	Multi-segment frequency 8	FA-08
1	0	0	1	Multi-segment frequency 9	FA-09
1	0	1	0	Multi-segment frequency 10	FA-10
1	0	1	1	Multi-segment frequency 11	FA-11
1	1	0	0	Multi-segment frequency 12	FA-12
1	1	0	1	Multi-segment frequency 13	FA-13
1	1	1	0	Multi-segment frequency 14	FA-14
1	1	1	1	Multi-segment frequency 15	FA-15

The dimension of multi-segment instruction is a relative value, which is the percentage of the relative maximum frequency F0-10. The positive and negative parameters determine the running direction. If it is negative, it means that the drive runs in reverse.

The function description of acceleration and deceleration time selection terminal is shown in the following table:

Terminal 1	Terminal 2	Acceleration or deceleration time selection	Corresponding parameter
0	0	Acceleration\Deceleration time 1	F0-17\F0-18
0	1	Acceleration\Deceleration time 2	F8-03\F8-04
1	0	Acceleration\Deceleration time 3	F8-05\F8-06
1	1	Acceleration\Deceleration time 4	F8-07\F8-08

F5-10	X terminal filtering time	Factory value	0. 010s	Attribute	○
	Setting range	0.000s ~ 1.000s			

It is used to set the filtering time of X terminal. Reducing this parameter can speed up the response time of X terminal, but also reduce its anti-interference ability; Increasing this parameter can enhance the anti-interference ability, but also slow down the response of X terminal.

F5-11	Terminal command mode	Factory value	0	Attribute	●
	Setting range	0	Two-wire type 1		
		1	Two-wire type 2		
		2	Three-wire type 1		
		3	Three-wire type 2		

X1 ~ X4 and HDI input terminals can be selected as external input terminals, that is, the functions of X1 ~ X4 and HDI input terminals can be selected by setting the values of F5.00 ~ F5.04.

0: Two-wire control mode 1:

As shown in the figure below, when K1 is connected alone, the drive runs forward; When K2 is connected alone, the drive runs in reverse; When K1 and K2 are connected or disconnected at the same time, the drive stops running.

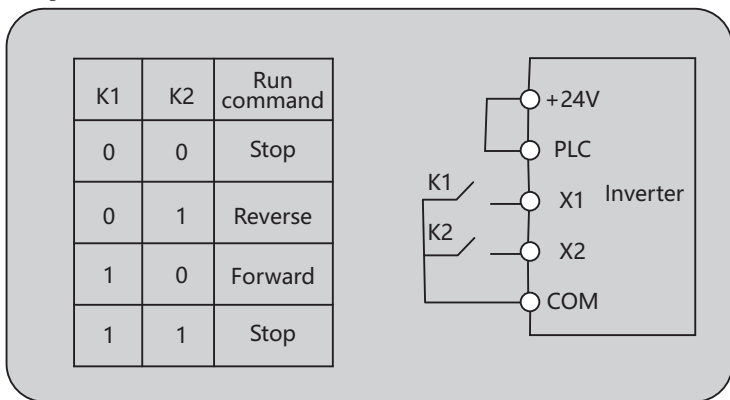

The function code is set as follows:

Function code	Name	Set value	Parameter description
F0-02	Run command channel selection	1	Terminal control
F5-11	Terminal control mode selection	0	Two-wire type 1
F5-00	X1 terminal function selection	1	Forward (FWD)
F5-01	X2 terminal function selection	2	Reverse (REV)

1: Two-wire control mode 2:

In this mode, the X1 terminal is the operation enable terminal, and the function of the X2 terminal is determined running direction. As shown in the figure below, when K1 is connected in this mode, K2 is disconnected and the drive runs forward, or K2 is connected and the drive runs in reverse; When K1 is disconnected, the drive stops running.

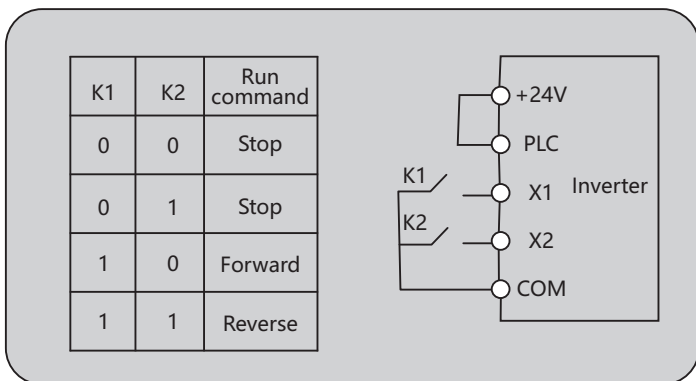

The function code is set as follows:

Function code	Name	Set value	Parameter description
F0-02	Run command channel selection	1	Terminal control
F5-11	Terminal control mode selection	1	Two-wire type 2
F5-00	X1 terminal function selection	1	Forward (acting as "operation enable")
F5-01	X2 terminal function selection	2	Reverse (acting as "forward and reverse direction")

2: Three-wire control mode 1:

In this mode, the X3 terminal is the operation enabling terminal, and the direction is controlled by X1 and X2 respectively. As shown in the figure below, in this control mode, when the SB1 key is in connected state, press SB2 to make the drive run forward, press SB3 to make the drive run reversely; when the SB1 key is disconnected, the drive stops.

During normal startup and operation, the SB1 key must be kept connected, and the command of the SB2 and SB3 keys takes effect whenever the connection action occurs. The running state of the drive is subject to the last action of the 3 keys.

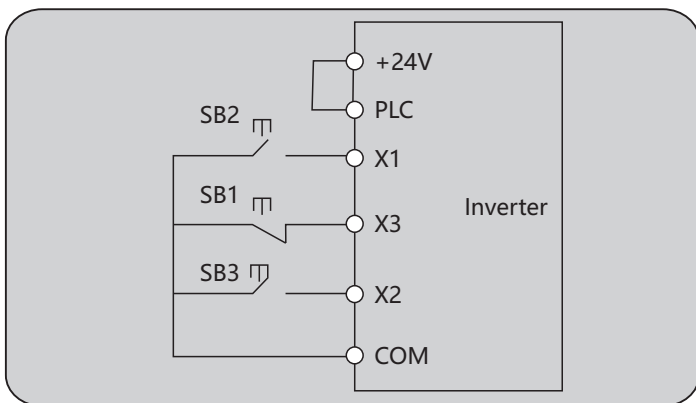

The function code is set as follows:

Function code	Name	Set value	Parameter description
F0-02	Run command channel selection	1	Terminal control
F5-11	Terminal control mode selection	2	Three-wire type 1
F5-00	X1 terminal function selection	1	Forward (FWD)
F5-01	X2 terminal function selection	2	Reverse (REV)
F5-02	X3 terminal function selection	3	Three-wire running control

3: Three-wire control mode 2:

In this mode, the X3 terminal is the running enabling terminal, the run command is set by X1, and the direction is determined by the state of X2. As shown in the figure below, in this control mode, when the SB1 key is closed, press the SB2 key to run the drive, disconnect K for forward rotation of the drive and connect K for reverse rotation of the drive; When the SB1 key is turned off, the drive stops. During normal startup and running, the SB1 key must be kept connected, and the command of the SB2 key will take effect at the edge of the connect action.

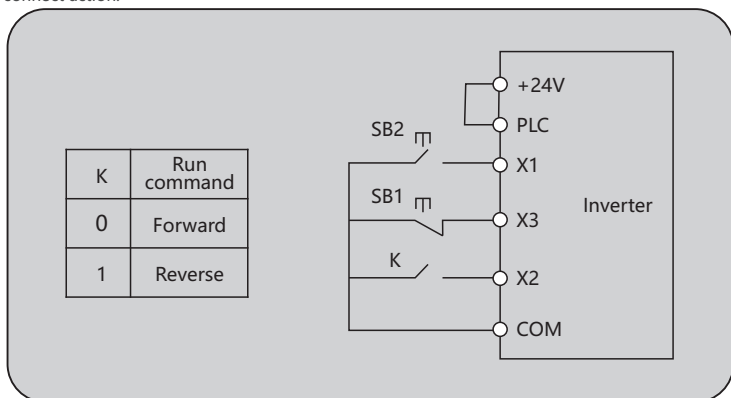

The function code is set as follows:

Function code	Name	Set value	Parameter description
F0-02	Run command channel selection	1	Terminal control
F5-11	Terminal control mode selection	3	Three-wire type 2
F5-00	X1 terminal function selection	1	Forward (acting as "operation enable")
F5-01	X2 terminal function selection	2	Reverse (acting as "forward and reverse direction")
F5-02	X3 terminal function selection	3	Three-wire running control

F5-12	Terminal UP/DOWN change rate	Factory value	1.00Hz/s	Attribute	○
	Setting range		0.001Hz/s~65.535Hz/s		

When using UP/DOWN to modify the target frequency, the speed of frequency change, that is, the change rate per second.

F5-13	Minimum input of AI curve 1	Factory value	0.00V	Attribute	○
	Setting range		0.00V~F5-15		
F5-14	Minimum input corresponding setting of AI curve 1	Factory value	0.00%	Attribute	○
	Setting range		-100.0%~+100.0%		

F5-15	Maximum input of AI curve 1	Factory value	10.00V	Attribute	○
	Setting range	F5-13~+10.00V			
F5-16	Maximum input corresponding setting of AI curve 1	Factory value	100.00%	Attribute	○
	Setting range	-100.0%~+150.0%			
F5-17	AI1 filtering time	Factory value	0.10s	Attribute	○
	Setting range	0.00s~10.00s			

The setting of AI curve is actually to set the relationship between analog input voltage (or analog input current) and its representative set frequency. When AI is set as frequency, 100.0% of the corresponding setting of voltage or current input refers to the relative (maximum output frequency F0-10) percentage. 2-point curve: Take curve 1 as an example, and the detailed parameters and descriptions are as follows:

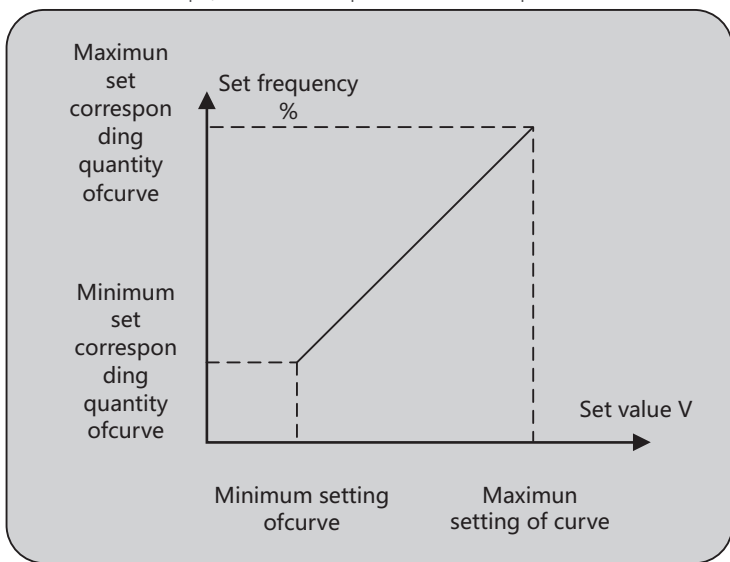

AI1 filtering time: It is used to set the software filtering time of AI1. The longer the filtering time, the stronger the anti-interference ability but the slower the response speed to analog detection.

F5-18	Minimum input of AI curve 2	Factory value	0.00V	Attribute	○
	Setting range	0.00V~F5-20			
F5-19	Minimum input corresponding setting of AI curve 2	Factory value	0.0%	Attribute	○
	Setting range	-100.0%~+100.0%			
F5-20	Maximum input of AI curve 2	Factory value	10.00V	Attribute	○
	Setting range	F5-18~+10.00V			
F5-21	Maximum input corresponding setting of AI curve 2	Factory value	100.0%	Attribute	○
	Setting range	-100.0%~+150.0%			
F5-22	AI2 filtering time	Factory value	0.10s	Attribute	○
	Setting range	0.00s~10.00s			

Please refer to the description of curve 1 for the function and usage of curve 2.

F5-23	Minimum input of AI curve 3	Factory value	-10.00V	Attribute	○
	Setting range	0.00V~F5-25			
F5-24	Minimum input corresponding setting of AI curve 3	Factory value	-100.0%	Attribute	○
	Setting range	-100.0%~+100.0%			
F5-25	Maximum input of AI curve 3	Factory value	10.00V	Attribute	○
	Setting range	F5-23~+10.00V			
F5-26	Maximum input corresponding setting of AI curve 3	Factory value	100.00%	Attribute	○
	Setting range	-100.0%~+150.0%			
F5-27	AI3 filtering time	Factory value	0.10s	Attribute	○
	Setting range	0.00s~10.00s			

Please refer to the description of curve 1 for the function and usage of curve 3.

F5-28	Minimum frequency of pulse input	Factory value	0.00KHz	Attribute	○
	Setting range	0.00KHz~F5-30			
F5-29	Corresponding setting of minimum input frequency of pulse	Factory value	0.00%	Attribute	○
	Setting range	-100.0%~+100.0%			
F5-30	Maximum input frequency of pulse	Factory value	50.00KHz	Attribute	○
	Setting range	F5-28~100.00kHz			
F5-31	Corresponding setting of maximum input frequency of pulse	Factory value	100.00%	Attribute	○
	Setting range	-100.0%~+100.0%			
F5-32	Pulse filtering time	Factory value	0.10s	Attribute	○
	Setting range	0.00s~10.00s			

This function code is used to set the relationship between HDI pulse frequency and the corresponding setting.

The pulse frequency can only be input into the drive through HDI channel.

The application of this group of functions is similar to curve 1, please refer to the description of curve 1.

F5-33	AI curve selection	Factory value	321	Attribute	○
	Setting range	Units	AI1 curve selection		
		1	Curve 1 (2 points, see F5-13~F5-16)		
		2	Curve 2 (2 points, see F5-18~F5-21)		
		3	Curve 3 (2 points, see F5-23~F5-26)		
		4	Curve 4 (4 points, see A0-00~A0-07)		
		5	Curve 5 (4 points, see A0-08~A0-15)		
		Tens	AI2 curve selection (1~5, same as above)		
Hundreds	AI3 curve selection (1~5, same as above)				

The units, tens and hundreds of the function code are used for selection respectively, and the analog inputs are the corresponding setting curves of AI1, AI2 and AI2. Any of the five curves can be selected respectively for any of the three analog curves.

Curves 1, 2 and 3 are all 2-point curves, which are set in F5 group function codes, while curves 4 and 5 are all 4-point curves, which need to be set in A0 group function codes.

The standard terminal of NVF7 drive provides two analog inputs, and the used AI3 shall be configured with multi-function input/output optional cards.

F5-34	Selection of AI below the minimum input setting		Factory value	000	Attribute	○
	Setting range	Units	Selection of AI1 below the minimum setting			
		0	Corresponding minimum input setting			
		1	0.0%			
		Tens	Selection of AI2 below the minimum input setting (0~1, same as above)			
Hundreds	Selection of AI3 below the minimum input setting (0~1, same as above)					

This function code is used to set how to determine the corresponding setting of analog when the voltage of analog input is less than the set "minimum input".

The units, tens and hundreds of this function code . correspond to analog inputs AI1, AI2 and AI3 respectively.

When the AI input is lower than the minimum input, if 0 is selected, the corresponding setting of the analog is the "minimum input corresponding setting" set by the function code; if 1 is selected, the corresponding setting of the analog is 0.0%.

F5-35	X1 delay time	Factory value	0.0s	Attribute	○
	Setting range	0.0s~3600.0s			
F5-36	X2 delay time	Factory value	0.0s	Attribute	○
	Setting range	0.0s~3600.0s			
F5-37	X3 delay time	Factory value	0.0s	Attribute	○
	Setting range	0.0s~3600.0s			

This function code is used to set the delay time for X terminal to change its state.

At present, X4 and HDI do not have this function.

F5-38	X terminal effective mode selection		Factory value	00000	Attribute	●
	Setting range	Units	X1 terminal valid state setting			
		0	High level valid			
		1	Low level valid			
		Tens	Valid state setting of X2 terminal (0~1, same as above)			
		Hundreds	Valid state setting of X3 terminal (0~1, same as above)			
		Thousands	Valid state setting of X4 terminal (0~1, same as above)			
Ten thousands	Valid state setting of HDI terminal (0~1, same as above)					

This function code is used to set the valid state mode of digital input terminal.

When 0 is selected, the communication between COM terminal and X terminal is valid, but the disconnection is invalid;

When 1 is selected, the communication between COM terminal and X terminal is invalid, but the disconnection is valid;

F5-41	AI1 measured voltage 1	Factory value	Factory correction	Attribute	○
	Setting range	-10.00V ~ 10.00V			
F5-42	AI1 displayed voltage 1	Factory value	Factory correction	Attribute	○
	Setting range	-10.00V ~ 10.00V			
F5-43	AI1 measured voltage 2	Factory value	Factory correction	Attribute	○
	Setting range	-10.00V ~ 10.00V			
F5-44	AI1 displayed voltage 2	Factory value	Factory correction	Attribute	○
	Setting range	-10.00V ~ 10.00V			
F5-45	AI2 measured voltage 1	Factory value	Factory correction	Attribute	○
	Setting range	-10.00V ~ 10.00V			
F5-46	AI2 displayed voltage 1	Factory value	Factory correction	Attribute	○
	Setting range	-10.00V ~ 10.00V			
F5-47	AI2 measured voltage 2	Factory value	Factory correction	Attribute	○
	Setting range	-10.00V ~ 10.00V			
F5-48	AI2 displayed voltage 2	Factory value	Factory correction	Attribute	○
	Setting range	-10.00V ~ 10.00V			
F5-49	AI3 measured voltage 1	Factory value	Factory correction	Attribute	○
	Setting range	-10.00V ~ 10.00V			
F5-50	AI3 displayed voltage 1	Factory value	Factory correction	Attribute	○
	Setting range	-10.00V ~ 10.00V			
F5-51	AI3 measured voltage 2	Factory value	Factory correction	Attribute	○
	Setting range	-10.00V ~ 10.00V			
F5-52	AI3 displayed voltage 2	Factory value	Factory correction	Attribute	○
	Setting range	-10.00V ~ 10.00V			

This group of function codes is used to correct analog AI to eliminate the influence of null bias and gain of AI input port.

This group of function code parameters has been corrected at the factory, and when the factory value is restored, it will be restored to the corrected factory value. Generally, it does not need to be modified at the application site.

The measured voltage refers to the actual voltage measured by measuring instruments such as multimeter, and the displayed voltage refers to the voltage display value sampled by drive. See AI voltage display before correction in U0 group (U0-21, U0-22, U0-23).

During correction, two voltage values are respectively input into each AI input port, and the values measured by multimeter and the values read by U0 group are accurately input into the above function codes, then the drive will automatically correct the null bias and gain of AI.

For occasions where the voltage set by the user does not match the actual sampling voltage of the drive, the field correction method can be adopted to make the sampling value of the drive consistent with the expected set value. Taking AI1 as an example, the field correction method is as follows:

1. Set the AI1 voltage signal (about 2V)
2. Measure the voltage value of AI1, and record it as V1
3. Check the displayed value of U0-21, and record it as V2
4. Set the AI1 voltage signal (about 8V)
5. Measure the voltage value of AI1, and record it as V3
6. Check the displayed value of U0-21, and record it as V4
7. Save parameter V1 in parameter F5-41, V2 in parameter F5-42, V3 in parameter F5-43 and V4 in parameter F5-44

When AI2 and AI3 are corrected, the actual sampling voltage viewing positions are U0-22 and U0-23 respectively. For AI1 and AI2, it is recommended to use 2V and 8V as correction points, and for AI3, it is recommended to sample -8V and 8V as correction points.

F5-53	AI2 measured current 1	Factory value	Factory correction	Attribute	○
	Setting range	0mA ~ 20.000mA			
F5-54	AI2 displayed current 1	Factory value	Factory correction	Attribute	○
	Setting range	0mA ~ 20.000mA			
F5-55	AI2 measured current 2	Factory value	Factory correction	Attribute	○
	Setting range	0mA ~ 20.000mA			
F5-56	AI2 displayed current 2	Factory value	Factory correction	Attribute	○
	Setting range	0mA ~ 20.000mA			

This group of function codes is used to correct the analog AI2 input current.

The correction method is consistent with the AI2 voltage correction method.

12.7 F6 group output terminal

F6-00	HDO terminal output mode selection		Factory value	0	Attribute	○
	Setting range	0	High speed pulse output			
		1	Switch output			

HDO terminal is a programmable multiplexing terminal, which can be used as a high-speed pulse output terminal and also as a switch output terminal of open collector.

As a high-speed pulse output terminal, the output pulse can reach up to 100KHz. See F6-06 for the specific function of HDO.

F6-01	HDO function selection	Factory value	0	Attribute	○
	Setting range	0~41			
F6-02	Function selection of relay RO1	Factory value	2	Attribute	○
	Setting range	0~41			
F6-04	Function selection of relay RO2	Factory value	1	Attribute	○
	Setting range	0~41			

The above function codes are used to set the functions of 3 digital outputs, and the functions of multi-function output terminals are described in the following table:

Set value	Function	Notes
0	No output	The output terminal has no function
1	Drive running	It means that the drive is running and has an output frequency (which can be zero), in which case the ON signal is output.
2	Fault output (fault stop)	When the drive is faulty and stops, the ON signal is output.
3	Frequency level detection FDT1 output	Please refer to the description of function codes F8-19 and F8-20.
4	Frequency reached	Please refer to the description of function codes F8-21.
5	Running at zero speed (no output when stopping)	When the drive is running and the output frequency is 0, the ON signal is output. When the drive is in stop state, the signal is OFF.
6	Motor overload pre-alarm	Before motor overload protection action, judge according to the threshold of overload pre-alarm, and output ON signal after the threshold of pre-alarm is exceeded. Refer to function codes FE-00 ~ FE-02 for motor overload parameter setting.
7	Drive overload pre-alarm	10s before the drive overload protection acts, output ON signal.
8	Set counting pulse reached	Please refer to the description of function codes F9-37.
9	Designated counting pulse reached	Please refer to the description of function codes F9-38.
10	Length reached	Please refer to the description of function codes F9-34 and F9-35.
11	PLC cycle completed	When the simple PLC runs for one cycle, it outputs a pulse signal with a width of 250 ms.

Set value	Function	Notes
12	Cumulative running time reached	When the cumulative running time of the drive exceeds the time set by F8-17, the ON signal is output.
13	Frequency limiting	When the set frequency exceeds the upper limiting frequency or the lower limiting frequency, and the output frequency of the drive also reaches the upper limiting frequency or the lower limiting frequency, the ON signal is output.
14	Torque limiting	In the speed control mode, when the output torque reaches the torque limit value, the drive is in the stall protection state and outputs the ON signal at the same time.
15	Ready for running	When the power supply of the main circuit and control circuit of the drive has been stabilized, and the drive has not detected any fault information, and the drive is in a runnable state, the ON signal is output.
16	AI1>AI2	When the value of analog input AI1 is greater than the input value of AI2, the ON signal is output.
17	Upper limiting frequency reached	When the operating frequency reaches the upper limiting frequency, the ON signal is output.
18	Lower limiting frequency reached (no output when stopping)	When the operating frequency reaches the lower limiting frequency, the ON signal is output. The signal is OFF in stop state.
19	Undervoltage state output	When the drive is undervoltage, the ON signal is output.
20	Communication control	Communication control
21	Reserved	Reserved
22	Reserved	Reserved
23	Running at zero speed 2 (also output when stopping)	When the output frequency of the drive is 0, the ON signal is output. The signal is also ON in stop state.
24	Cumulative power-on time reached	When the cumulative power-on time (U0-80) of the drive exceeds the time set by F8-16, the ON signal is output.
25	Frequency level detection FDT2 output	Please refer to the description of function codes F8-28 and F8-29.
26	Output of frequency 1 reached	Please refer to the description of function codes F8-30 and F8-31.
27	Output of frequency 2 reached	Please refer to the description of function codes F8-32 and F8-33.
28	Output of current 1 reached	Please refer to the description of function codes F8-38 and F8-39.
29	Output of current 2 reached	Please refer to the description of function codes F8-40 and F8-41.
30	Output of timing reached	When the timing function selection (F8-42) is valid, the drive will output the ON signal after the current running time reaches the set time.
31	AI1 input overrun	When the value of analog input AI1 is greater than F8-46 (the upper limit of AI1 input protection) or less than F8-45 (the lower limit of AI1 input protection), the ON signal is output.
32	Unloading	When the drive is in unloading state, the ON signal is output.
33	In reverse running	When the drive is reverse running, the ON signal is output
34	Zero current state	Please refer to the description of function codes F8-34 and F8-35
35	Module temperature reached	When the radiator temperature of the inversion module (U0-75) reaches the set module temperature reached (F8-47), the ON signal is output

Set value	Function	Notes
36	Software current overrun	Please refer to the description of function codes F8-36 and F8-37.
37	Lower limiting frequency reached (also output when stopping)	When the operating frequency reaches the lower limiting frequency, the ON signal is output. The signal is also ON in stop state.
38	Alarm output	When the drive fails with a fault to be handled by continuous running, the drive is subject to alarm output.
39	Reserved	Reserved
40	Current running time reached	When the start running time of the drive exceeds the time set by F8-53, the ON signal is output.
41	Fault output	The fault of free stop and undervoltage are not output.

F6-06	HDO function selection	Factory value	0	Attribute	○
	Setting range		0~16		
F6-07	AO1 output function selection	Factory value	0	Attribute	○
	Setting range		0~16		
F6-08	AO2 output function selection	Factory value	1	Attribute	○
	Setting range		0~16		

The output pulse frequency of HDO terminal ranges from 0.01 kHz to F6-09 (the maximum output frequency of HDO), and F6-09 can be set between 0.01 kHz and 100.00 kHz.

The analog output AO1 and AO2 range from 0V to 10V, or from 0mA to 20mA. The calibration relationship between the range of pulse output or analog output and the corresponding function is shown in the following table:

Set value	Function	Functional scope (corresponding to 0.0%~100.0% of pulse or analog output)
0	Operating frequency	0 ~ maximum output power
1	Set frequency	0 ~ maximum output power
2	Output current	0 ~ 2 times rated current of motor
3	Output torque (absolute value)	0 ~ 2 times rated torque of motor
4	Output power	0 ~ 1 times rated power of motor
5	Output voltage	0 ~ 1.2 times rated voltage of drive
6	PULSE input	0.01kHz ~ 100.00kHz
7	AI1	0V ~ 10V (or 0 ~ 20mA)
8	AI2	0V ~ 10V (or 0 ~ 20mA)
9	AI3	0V ~ 10V (or 0 ~ 20mA)
10	Length	0 ~ maximum set length
11	Count value	0 ~ maximum count value
12	Communication setting	0.0% ~ 100.0%
13	Motor speed	Speed corresponding to 0 ~ maximum output frequency
14	Output current	0.0A ~ 1000.0A
15	Output voltage	0.0V ~ 1000.0V
16	Motor output torque (actual value, percentage relative to motor)	-2 times the rated torque of motor ~ 2 times the rated torque of motor

F6-09	Maximum frequency of HDO output	Factory value	50.00kHz	Attribute	○
	Setting range		0.01kHz ~ 100.00kHz		

This function code is used to set the HDO terminal as the upper limit of high-speed pulse output.

F6-10	AO1 zero bias coefficient	Factory value	0.00%	Attribute	○
	Setting range		-100.0% ~ +100.0%		

F6-11	AO1 gain	Factory value	1	Attribute	○
	Setting range	-10.00 ~ +10.00			
F6-12	AO2 zero bias coefficient	Factory value	0.00%	Attribute	○
	Setting range	-100.0% ~ +100.0%			
F6-13	AO2 gain	Factory value	1	Attribute	○
	Setting range	-10.00 ~ +10.00			

This function code is used to set the null bias and gain of AO1 and AO2 analog outputs. When the actual setting is different from the display of the drive, it can be corrected by this parameter, and it can also be used to customize the AO curve.

If the null bias is represented by "A", the gain is represented by k, the actual output is represented by Y, and the standard output is represented by X, then the actual output is:

$$Y = kX + a$$

Wherein, the null bias coefficient of AO1 and AO2 is 100% corresponding to 10V (or 20mA), and the standard output refers to the quantity represented by the analog output corresponding to the output of 0V ~ 10V (or 0MA ~ 20MA) without null bias and gain correction.

For example, if the analog output content is the operating frequency, and it is expected that the actual output is 8V when the frequency is 0 and 3V when the frequency is the maximum, the gain shall be set to "-0.5" and the null bias shall be set to "80%".

F6-17	HDO output delay time	Factory value	0.0s	Attribute	○
	Setting range	0.0s ~ 3600.0s			
F6-18	RO1 output delay time	Factory value	0.0s	Attribute	○
	Setting range	0.0s ~ 3600.0s			
F6-19	DO1 output delay time	Factory value	0.0s	Attribute	○
	Setting range	0.0s ~ 3600.0s			
F6-20	RO2 output delay time	Factory value	0.0s	Attribute	○
	Setting range	0.0s ~ 3600.0s			
F6-21	DO2 output delay time	Factory value	0.0s	Attribute	○
	Setting range	0.0s ~ 3600.0s			

The above function code is used to set the delay time from the state occurrence to the actual output change of HDO output terminal, relay 1 and relay 2.

F6-22	Valid state selection of DO output terminal	Factory value	00000	Attribute	○
	Setting range	Units	HDO		
		0	Positive logic		
		1	Negative logic		
		Tens	RO1		
		Hundreds	DO1		
		Thousands	RO2		
Ten thousands	DO2				

This function code is used to set the output logic of HDO output terminal, relay 1 and relay 2.

0: Positive logic, if the digital output terminal and the corresponding common terminal are connected, it is a valid state, otherwise, it is an invalid state;

1: Negative logic, if the digital output terminal and the corresponding common terminal are connected, it is an invalid state, otherwise, it is a valid state.

F6-24	AO1 target voltage 1	Factory value	Factory correction	Attribute	○
	Setting range	-10.00V ~ 10.00V			
F6-25	AO1 measured voltage 1	Factory value	Factory correction	Attribute	○
	Setting range	-10.00V ~ 10.00V			

F6-26	AO1 target voltage 2	Factory value	Factory correction	Attribute	○
	Setting range	-10.00V ~ 10.00V			
F6-27	AO1 measured voltage 2	Factory value	Factory correction	Attribute	○
	Setting range	-10.00V ~ 10.00V			
F6-28	AO2 target voltage 1	Factory value	Factory correction	Attribute	○
	Setting range	-10.00V ~ 10.00V			
F6-29	AO2 measured voltage 1	Factory value	Factory correction	Attribute	○
	Setting range	-10.00V ~ 10.00V			
F6-30	AO2 target voltage 2	Factory value	Factory correction	Attribute	○
	Setting range	-10.00V ~ 10.00V			
F6-31	AO2 measured voltage 2	Factory value	Factory correction	Attribute	○
	Setting range	-10.00V ~ 10.00V			
F6-32	AO1 ideal current 1	Factory value	Factory correction	Attribute	○
	Setting range	0.000mA ~ 20.000mA			
F6-33	AO1 measured current 1	Factory value	Factory correction	Attribute	○
	Setting range	0.000mA ~ 20.000mA			
F6-34	AO1 ideal current 2	Factory value	Factory correction	Attribute	○
	Setting range	0.000mA ~ 20.000mA			
F6-35	AO1 measured current 2	Factory value	Factory correction	Attribute	○
	Setting range	0.000mA ~ 20.000mA			

The above function code is used to correct the analog output AO. The above functional parameter has been corrected at the factory, and when the factory value is restored, it will be restored to the corrected factory value. Generally, it does not need to be corrected at the application site.

The target voltage refers to the theoretical output voltage value of the drive. The measured voltage refers to the actual output voltage measured by multimeter and other instruments.

12.8 F7 group keyboard and display

F7-00	User password	Factory value	0	Attribute	○
	Setting range	0 ~ 65535			

This function code is used to set the user protection password. If you set any number, the password protection function will be enabled. You must enter the correct password the next time you enter the menu. Please remember the user password.

If this function code is set to 0, the set user password will be cleared, making the password protection function disabled.

F7-01	Digital tube self-inspection	Factory value	0	Attribute	○
	Setting range	0: No inspection 1: All digital tubes are lit			

This function code is used to set the digital tube self-inspection on the display panel. When it is set to 1, all digital tubes are lit.

F7-02	MF key function selection	Factory value	0	Attribute	●	
	Setting range	0	Invalid MF function key			
		1	Switch between the command channel of the operation panel and the remote command channel (terminal command channel or communication command channel)			
		2	Forward and reverse running switching			
		3	Forward jog			
4	Reverse jog					

This function code is used to set the function of MF key. This key can be used to switch between stop and running.

0: No function

1: Keyboard command and remote operation switching

It refers to the switch of command source, that is, the switch between the current command source and keyboard control (local operation). If the current command source is keyboard control, this key function is invalid.

2: Forward and reverse running switching

Switch the direction of frequency instruction by MF key. This function is only valid when the command source is the command channel of the operation panel.

3: Forward jog

Forward jog (FJOG) is realized by keyboard MF key.

4: Reverse jog

Reverse jog (RJOG) is realized by keyboard MF key.

	STOP/RESET key function		Factory value	1	Attribute	○
F7-03	Setting range	0	STOP/RES key stop function is valid only in keyboard operation mode			
		1	In any operation mode, the stop function of STOP/RES key is effective			
F7-04	LED running display parameter 1		Factory value	1F	Attribute	○
	Setting range	0000~FFFF				

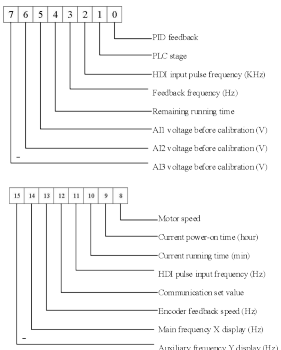
F7-05	LED running display parameter 2	Factory value	0	Attribute	○
	Setting range	0000~FFFF			

Running display parameter: It is used to set the parameters that can be viewed when the drive is running.

The maximum number of state parameters available for viewing is 32. Select the state parameters to be displayed according to the binary digits of the parameter values F7-04 and F7-05, and the display order starts from the lowest digit of F7-04.

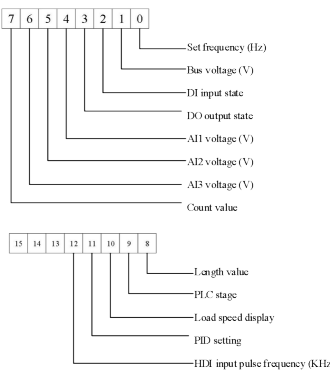
F7-06	LED shutdown display parameter	Factory value	33	Attribute	○
	Setting range	0000~FFFF			
F7-07	Load speed display coefficient	Factory value	1.0000	Attribute	○
	Setting range	0.001 ~ 6.5000			

When the load speed needs to be displayed, through this parameter, the corresponding relationship between the output frequency of the drive and the load speed is adjusted. Refer to F7-08 for specific correspondence.

F7-08	Number of decimal places of load speed display		Factory value	21	Attribute	○
	Setting range	Units	Decimal place in U0-14			
		0	0-digit decimal display			
		1	1-digit decimal display			
		2	2-digit decimal display			
		3	3-digit decimal display			
		Tens	Decimal place in U0-19/U0-29			
	1	1 decimal point				
2	2 decimal point					

This function code is used to set the number of decimal places for load speed display.

For example, the load speed display coefficient F7-07 is 2.000, the number of load speed decimal places F7-08 is 2, and when the drive runs at 40.00Hz, the load speed is $40.00 \times 2.000 = 80.00$ (2 is decimal place display); If the drive is in the stop state, the load display speed corresponds to the set frequency.

Tens:

1: U0-19/U0-29 are displayed with one decimal place respectively.

2: U0-19/U0-29 are displayed with two decimal place respectively.

F7-09	Display selection of function parameter group		Factory value	11	Attribute	●
	Setting range	Units	Display selection of U group			
		0	Not display			
		1	Display			
		Tens	Display selection of A group			
		0	Not display			
1	Display					
F7-10	Display selection of personalized parameter mode		Factory value	00	Attribute	○
	Setting range	Units	Display selection of user-defined parameter			
		0	Not display			
		1	Display			
		Tens	Display selection of user change parameter			
		0	Not display			
1	Display					

The establishment of parameter display mode is mainly convenient for users to view different arrangement of functional parameters according to actual needs, with three parameter display methods provided.

Name	Description
Functional parameter mode	The functional parameters of drive are displayed in sequence, including F0~FE, A0, A5 and U0 respectively
User-defined parameter mode	User-defined individual function parameters for display (up to 32): The user can determine the functional parameters to be displayed through FF group
User-changed parameter mode	Parameters inconsistent with factory parameters

When one of the display options of customized parameter mode (F7-10) is display, you can switch to different parameter display methods by using the QUICK key, and only the functional parameter method is available by default.

The display code of each parameter display mode is:

Parameter display	Display
Full-function parameter	-ALL-
User-defined parameters	- -U- -
User-changed parameters	- -C- -

NVF7 drive provides two sets of customized parameter display modes: user-defined parameter mode and user-changed parameter mode. User-defined parameter group refers to the parameters set to FF group by users, with a maximum of 32 parameters to be selected. These parameters can be summarized together, which is convenient for customers to debug.

In the user-defined parameter mode, a symbol U is added by default before the user-defined function code, for example: F1-00, in the user-defined parameter mode, the display effect is uF1-00.

In the user-changed parameter mode, the parameters are changed by users, which are different from the factory values of manufacturers. User-changed parameter group is helpful for customers to view the summary of changed parameters and find problems on site.

In the user-changed parameter mode, a symbol c is added before the user-defined function code by default, for example, F1-00. In the user-changed parameter mode, the display effect is cF1-00.

F7-11	Parameter change attribute		Factory value	0	Attribute	o
	Setting range	0	Modifiable			
		1	Non-modifiable			

Whether the user-set function code parameter of this function code can be modified, to prevent the parameters from being modified by mistake.

0:All function codes can be modified;

1:All function codes cannot be modified.

12.9 F8 group auxiliary function

F8-00	Jog operating frequency	Factory value	2.00Hz	Attribute	o
	Setting range	0.00Hz ~ maximum frequency			
F8-01	Jog acceleration time	Factory value	20.0s	Attribute	o
	Setting range	0.00s ~ 650.00s (F0-19=2)			
		0.0s ~ 6500.0s (F0-19=1) 0s ~ 65000s (F0-19=0)			
F8-02	Jog deceleration time	Factory value	20.0s	Attribute	o
	Setting range	0.00s ~ 650.00s (F0-19=2)			
		0.0s ~ 6500.0s (F0-19=1) 0s ~ 65000s (F0-19=0)			

During jogging running, the start mode is fixed as direct start, and the stop mode is fixed as stop by deceleration.

F8-03	Acceleration time 2	Factory value	Model determination	Attribute	o
	Setting range	0.00s ~ 650.00s (F0-19=2) 0.0s ~ 6500.0s (F0-19=1) 0s ~ 65000s (F0-19=0)			
F8-04	Deceleration time 2	Factory value	Model determination	Attribute	o
	Setting range	0.00s ~ 650.00s (F0-19=2)			
		0.0s ~ 6500.0s (F0-19=1) 0s ~ 65000s (F0-19=0)			
F8-05	Acceleration time 3	Factory value	Model determination	Attribute	o
	Setting range	0.00s ~ 650.00s (F0-19=2) 0.0s ~ 6500.0s (F0-19=1) 0s ~ 65000s (F0-19=0)			

F8-06	Deceleration time 3	Factory value	Model determination	Attribute	○
	Setting range		0.00s ~ 650.00s (F0-19=2) 0.0s ~ 6500.0s (F0-19=1) 0s ~ 65000s (F0-19=0)		
F8-07	Acceleration time 4	Factory value	0.0s	Attribute	○
	Setting range		0.00s ~ 650.00s (F0-19=2) 0.0s ~ 6500.0s (F0-19=1) 0s ~ 65000s (F0-19=0)		
F8-08	Deceleration time 4	Factory value	0.0s	Attribute	○
	Setting range		0.00s ~ 650.00s (F0-19=2) 0.0s ~ 6500.0s (F0-19=1) 0s ~ 65000s (F0-19=0)		

Through different combinations of multi-function digital input terminals X, you can switch between acceleration and deceleration time 1 and acceleration and deceleration time 4. Please refer to the X function description section for specific usage. Where, in the torque mode of drive vector control, the output frequency change corresponds to the acceleration and deceleration time 4, which is 0s by default.

F8-09	Jump frequency 1	Factory value	0.00Hz	Attribute	○
	Setting range		0.00Hz ~ maximum frequency		
F8-10	Jump frequency 2	Factory value	0.00Hz	Attribute	○
	Setting range		0.00Hz ~ maximum frequency		
F8-11	Jump frequency amplitude	Factory value	0.00Hz	Attribute	○
	Setting range		0.00Hz ~ maximum frequency		

When the set frequency is within the jump frequency range, the actual operating frequency will run at the jump frequency close to the set frequency. By setting the jump frequency, the drive can avoid the mechanical resonance point of the load. Two jump frequency points can be set. If both jump frequencies are set to 0Hz, the jump frequency function will be cancelled. The principle of jump frequency and jump frequency amplitude is shown in the following figure:

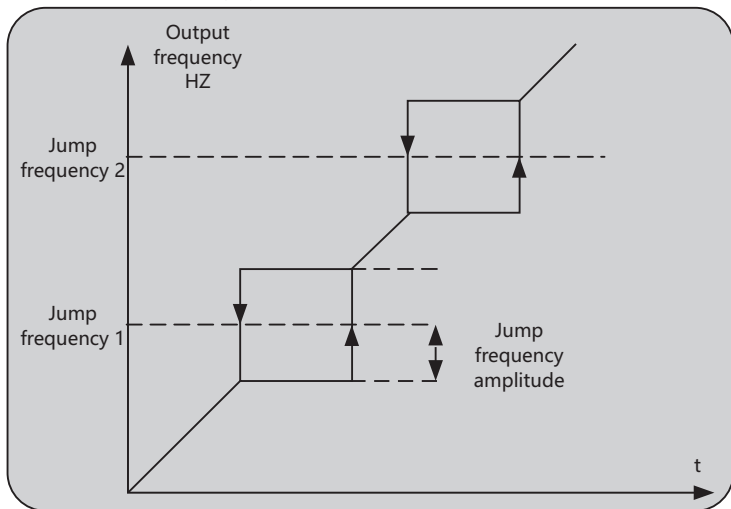

F8-12	Dead time of forward and reverse running	Factory value	0.0s	Attribute	○
	Setting range	0.0s ~ 3000.0s			

This parameter is used to set the holding time at 0Hz when the drive switches from forward (reverse) running to reverse (forward) running.

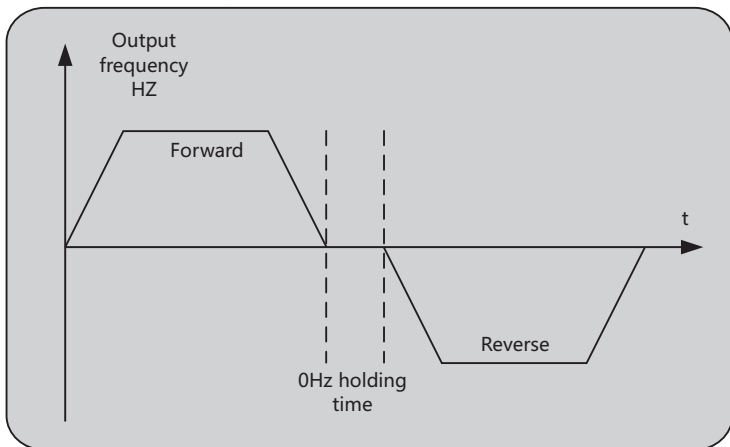

F8-13	Reverse frequency disabling	Factory value	0	Attribute	○
	Setting range	0	Invalid		
		1	Valid		

This parameter is used to set whether the motor is allowed to run in reverse. If the motor is not allowed to run in reverse, it is necessary to validate the reverse frequency disabling.

F8-14	Set frequency lower than the lower limiting frequency operation mode	Factory value	0	Attribute	○
	Setting range	0	Run at the lower limiting frequency		
		1	Stop		
		2	Run at zero-speed		

This parameter can be used to set the running state when the set frequency of the drive is lower than the lower limiting frequency.

F8-15	Droop rate	Factory value	0.00%	Attribute	○
	Setting range	0.00% ~ 10.00%			

In the master-slave control system, the droop rate allows a slight speed difference between the master station and the slave station.

The droop rate needs to be adjusted only when the master and slave adopt speed control mode. The droop rate needs to be set according to the actual application. It is recommended not to set F8-15 too large, otherwise the steady-state speed will decrease obviously when the load is heavy. The droop rate must be set for both master and slave.

Droop speed = Synchronous frequency × Output torque × Droop rate ÷ 10

Example: F8-15 = 1.00, synchronous frequency 50Hz, output torque (relative to motor rated torque) 50%, then:

Droop speed = 50Hz × 50% × 1.00 ÷ 10 = 2.5Hz

Actual frequency of drive = 50Hz - 2.5Hz = 47.5Hz

F8-16	Set cumulative power-on reaching time	Factory value	0h	Attribute	○
	Setting range	0h ~ 65000h			

When the cumulative power-on time (U0-80) of the drive reaches the set time of this parameter, the multi-function digital DO can be set to output the ON signal.

F8-17	Set cumulative running reaching time	Factory value	0h	Attribute	●
	Setting range	0h ~ 65000h			

When the cumulative running time (U0-77) of the drive reaches the set time of this parameter, the multi-function digital DO can be set to output the ON signal.

F8-18	Start protection selection	Factory value	0	Attribute	○
	Setting range	0	Not protected		
		1	Protection		

This parameter relates to the safety protection function of the drive.

If this parameter is set to 1, and when the run command is valid at the power-on moment of the drive or at the fault reset moment (for example, the terminal run command is disconnected before power-on), the drive does not respond to the run command, and the run command must be removed once before the drive responds.

Set this parameter to 1 to prevent the danger caused by the motor responding to the run command when power-on or fault reset without knowing it.

F8-19	Frequency detection value 1 (FDT1)	Factory value	50.00Hz	Attribute	○
	Setting range	0.00Hz ~ maximum frequency			
F8-20	Frequency detection lag rate 1	Factory value	5.0%	Attribute	○
	Setting range	0.0% ~ 100.0%			

When the operating frequency is higher than the frequency detection value, the multi-function output DO of the drive outputs the ON signal, and when the frequency is lower than the detection value by a certain frequency value, the DO output ON signal is cancelled.

The above parameters are used to set the detection value of output frequency and the lag value of output action cancellation. Where, F8-20 is the percentage of the lag frequency relative to the frequency detection value F8-19. The following figure is the schematic diagram of FDT function:

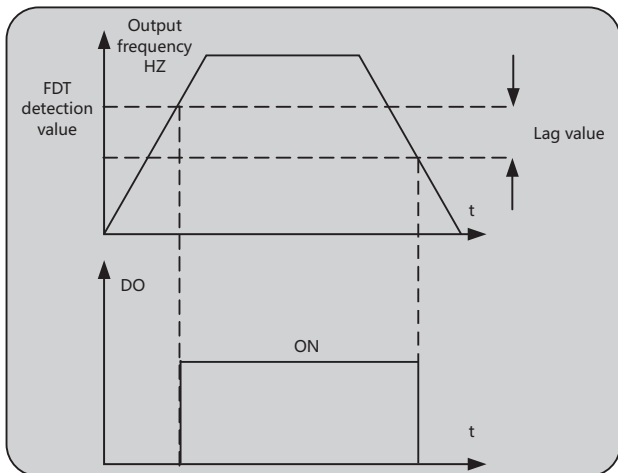

F8-21	Frequency reaching detection width	Factory value	0.0%	Attribute	○
	Setting range	0.0% ~ 100.0% (maximum frequency)			

When the operating frequency of the drive reaches between (set frequency - frequency reached detection width) and (set frequency + frequency reached detection width), the multi-function DO of the drive outputs the ON signal. This parameter is the percentage relative to the maximum frequency, and the frequency reaching function is shown below:

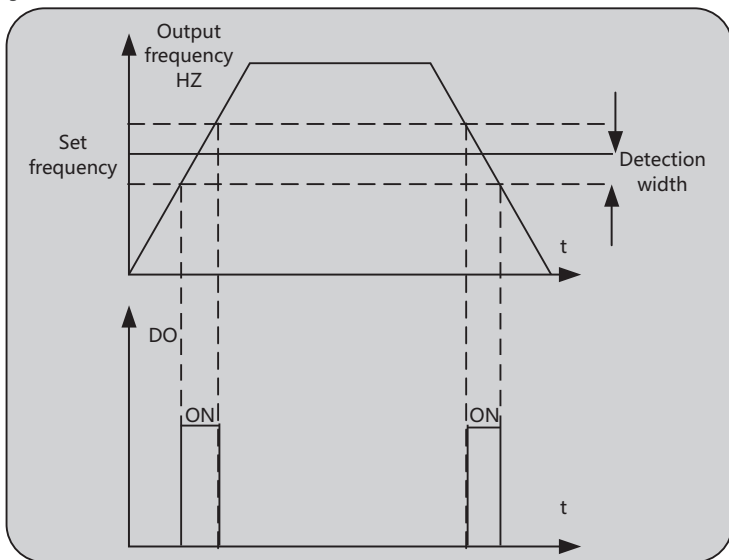

F8-22	Jump frequency in acceleration and deceleration process	Factory value	0	Attribute	○
	Valid selection	0	Invalid		
	Setting range	1	Valid		

When the jump frequency is set to be valid during acceleration and deceleration, the actual operating frequency will skip the set jump frequency range during acceleration or deceleration of the drive.

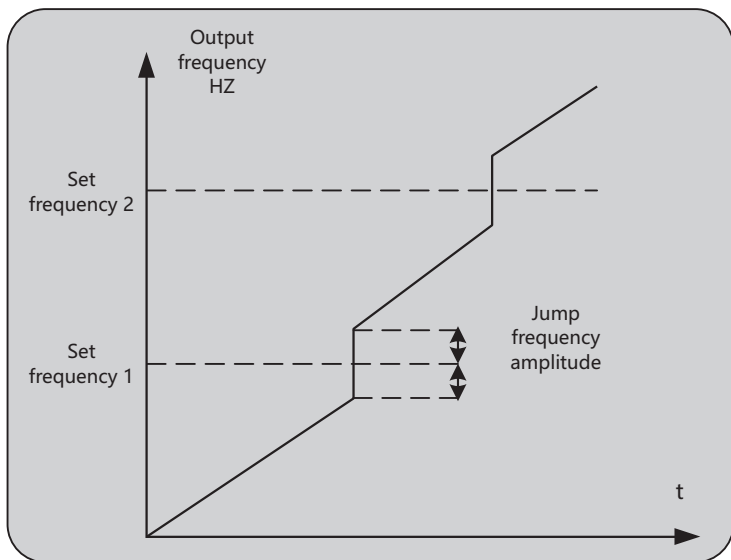

F8-25	Switching of acceleration time 1 and 2 Frequency	Factory value	0.00Hz	Attribute	○
	Setting range	0.00Hz ~ maximum frequency			
F8-26	Switching of deceleration time 1 and 2 Frequency	Factory value	0.00Hz	Attribute	○
	Setting range	0.00Hz ~ maximum frequency			

When the drive fails to select the acceleration and deceleration time through the X terminal, different acceleration and deceleration times can be switched according to the operating frequency.

During acceleration, when the operating frequency is less than F8-25, select acceleration time 2; When the operating frequency is greater than F8-25, select acceleration time 1.

During deceleration, when the running frequency is less than F8-26, select acceleration time 2; When the operating frequency is greater than F8-26, select acceleration time 1.

F8-27	Terminal jog priority	Factory value	0	Attribute	○
	Setting range	0	Invalid		
		1	Valid		

This parameter is used to set whether the terminal jog function has the highest priority. When terminal jog is first invalid, if the terminal jog command appears during running, the drive is switched to the terminal jog running state.

F8-28	Frequency detection value 2(FDT2)	Factory value	50.00Hz	Attribute	○
	Setting range	0.00Hz ~ maximum frequency			
F8-29	Frequency detection lag rate 2	Factory value	5.0%	Attribute	○
	Setting range	0.0% ~ 100.0%			

This function is the same as that of FDT1. Please refer to the relevant instructions of F8-19 and F8-20.

F8-30	Arbitrary reaching frequency detection value 1	Factory value	50.00Hz	Attribute	○
	Setting range	0.00Hz ~ maximum frequency			
F8-31	Arbitrary reaching frequency detection width 1	Factory value	0.0%	Attribute	○
	Setting range	0.0% ~ 100.0% (maximum frequency)			
F8-32	Arbitrary reaching frequency detection value 2	Factory value	50.00Hz	Attribute	○
	Setting range	0.00Hz ~ maximum frequency			
F8-33	Arbitrary reaching frequency detection value 2	Factory value	0.0%	Attribute	○
	Setting range	0.0% ~ 100.0% (maximum frequency)			

When the operating frequency of the drive reaches between (any frequency-frequency reached detection width) and (any frequency + frequency reached detection width), the multi-function DO of the drive outputs the ON signal. The function of any frequency reaching detection is as follows:

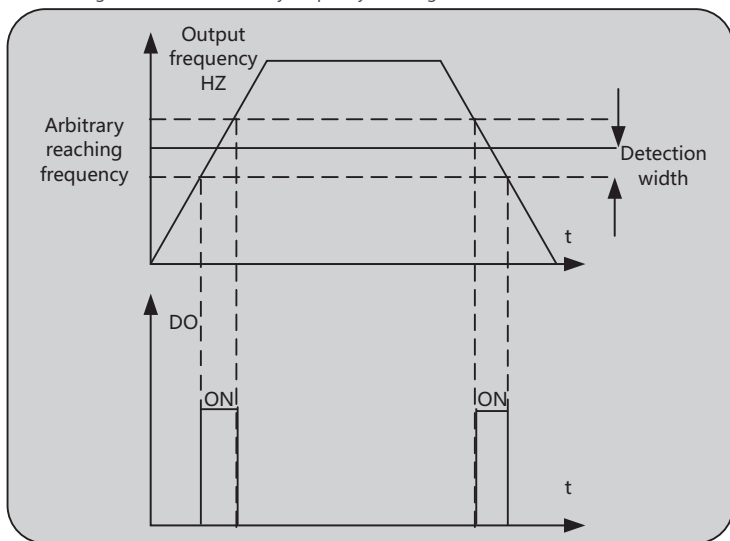

F8-34	Zero current detection level	Factory value	5.0%	Attribute	○
	Setting range	0.0% ~ 300.0% (motor rated current)			
F8-35	Zero current detection delay time	Factory value	0.10s	Attribute	○
	Setting range	0.01s ~ 600.00s			

When the output current of the drive is less than or equal to the zero current detection level and the duration exceeds the zero current detection delay time, the multi-function DO of the drive outputs the ON signal. The zero current detection is as shown in the figure:

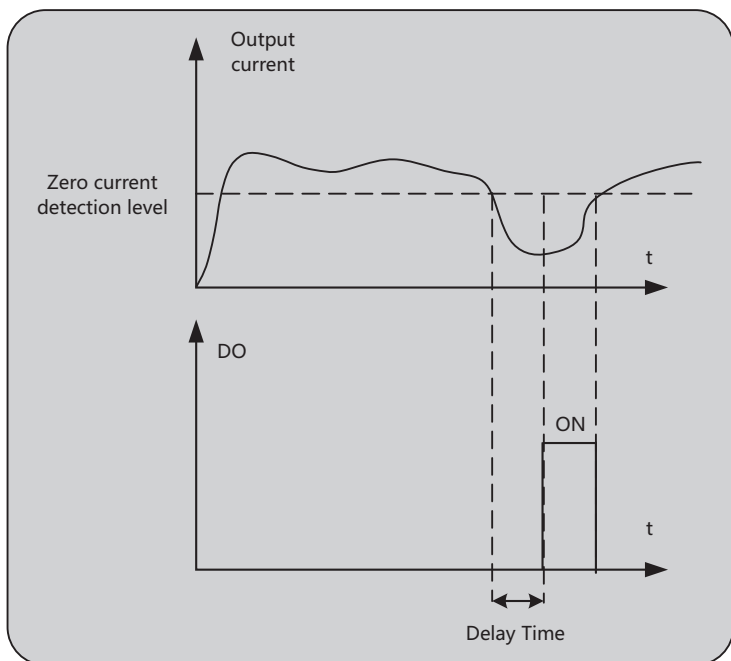

F8-36	Output current overrun value	Factory value	200.0%	Attribute	○
	Setting range	0.0% ~ 300.0% (motor rated current)			
F8-37	Output current overrun delay time	Factory value	0.00s	Attribute	○
	Setting range	0.00s ~ 600.00s			

When the output current of the drive is greater than or equal to the overrun detection point, and the duration exceeds the software overcurrent point detection delay time, the multi-function DO of the drive outputs the ON signal, and the output current overrun function is shown as follows:

When F8-36 current overrun value is set to 0.0%, it will not be detected.

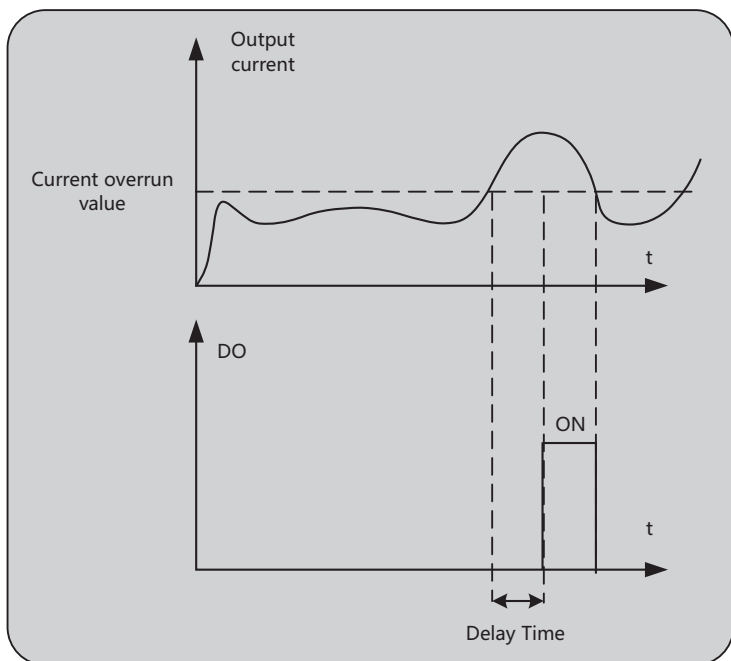

F8-38	Arbitrary reaching current 1	Factory value	100.0%	Attribute	○
	Setting range	0.0% ~ 300.0% (motor rated current)			
F8-39	Arbitrary reaching current 1 amplitude	Factory value	0.0%	Attribute	○
	Setting range	0.0% ~ 300.0% (motor rated current)			
F8-40	Arbitrary reaching current 2	Factory value	100.0%	Attribute	○
	Setting range	0.0% ~ 300.0% (motor rated current)			
F8-41	Arbitrary reaching current 2 amplitude	Factory value	0.0%	Attribute	○
	Setting range	0.0% ~ 300.0% (motor rated current)			

When the output current of the drive is within the set positive and negative detected width of any reached current, the multi-function DO of the drive outputs the ON signal.

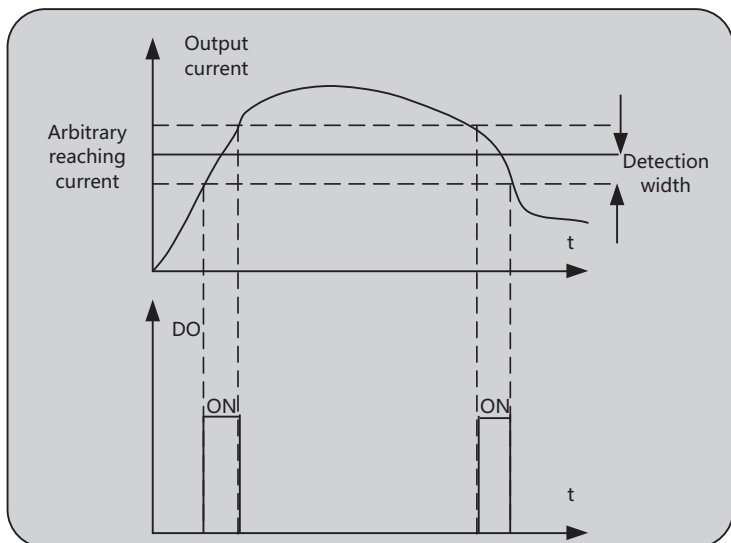

F8-42	Selection of timing function		Factory value	0	Attribute	*
	Setting range	0	Invalid			
		1	Valid			
F8-43	Time selection of timing run		Factory value	0	Attribute	*
	Setting range	0	F8-44 setting			
		1	AI1			
		2	AI2			
		3	AI3			
F8-44	Timing run time		Factory value	0.0Min	Attribute	*
	Setting range	0.0Min ~ 6500.0Min				

Time run function:

When the timing function is valid, the drive starts to run at 0 every time. When the set time run time is reached, the drive automatically stops. If the digital multi-function DO or relay output adopts the <time reaching> function, the ON signal is output. The remaining running time can be viewed through U0-20.

Note: The analog setting in F8-43 parameters is 100% corresponding to the setting time of F8-44.

F8-45	Lower limit of AI1 input voltage protection value	Factory value	3.10V	Attribute	o
	Setting range	0.00V ~ F8-46			
F8-46	Upper limit of AI1 input voltage protection value	Factory value	6.80V	Attribute	o
	Setting range	F8-45 ~ 11.00V			

If the function of <AI1 input overrun> is selected for digital multi-function DO or relay output, DO outputs the ON signal when the analog AI1 input voltage (after calibration) is greater than F8-46 or the AI1 input is less than F8-45.

F8-47	Module temperature reached	Factory value	75°C	Attribute	o
	Setting range	0°C ~ 100°C			

If the <module temperature reached> function is selected for the digital multi-function DO or relay output, DO outputs the ON signal when the inversion module temperature reaches the set temperature.

F8-48	Cooling fan control		Factory value	0	Attribute	●
	Setting range	0	When running, the fan runs			
		1	The fan keeps running			

Fan control mode 0: When the drive is running, the fan runs. When the radiator temperature is higher than 40°C in the stop state, the fan continues to run; When the radiator temperature is lower than 40°C, the fan stops running.

Fan control mode 1: The fan keeps running after powered on.

F8-49	Wake-up frequency	Factory value	0.00Hz	Attribute	○
	Setting range	F8-51 ~ maximum frequency			
F8-50	Wake-up delay time	Factory value	0.0s	Attribute	○
	Setting range	0.0s ~ 6500.0s			
F8-51	Sleep frequency	Factory value	0.00Hz	Attribute	○
	Setting range	0.00Hz ~ F8-49			
F8-52	Sleep delay time	Factory value	0.0s	Attribute	○
	Setting range	0.0s ~ 6500.0s			

During the running of the drive, when the set frequency is less than or equal to F8-51 sleep frequency, after F8-52 delay time, the drive enters the sleep state and automatically stops. If the drive is in sleep state and the current run command is valid, the drive will start after a delay time of F8-50 when the set frequency is greater than or equal to F8-49 wake-up frequency. If both the wake-up frequency and the sleep frequency are set to 0.00Hz, the sleep and wake-up functions are invalid.

Note: When the sleep function is enabled, if PID is used as the frequency source, PID shutdown operation must be selected at this time (F9-28).

F8-53	Current running time reached	Factory value	0.0Min	Attribute	●
	Setting range	0.0Min ~ 6500.0Min			

If the digital multi-function DO or relay output selects the <this running time reached> function, when the drive reaches this set time, DO outputs the ON signal.

F8-54	Output power correction coefficient	Factory value	100.0%	Attribute	○
	Setting range	0.0% ~ 200.0%			

This parameter is used to correct the output power displayed in U0-05.

F8-55	DPWM switching upper limiting frequency	Factory value	8.00Hz	Attribute	○
	Setting range	5.00Hz ~ maximum frequency			

When the operating frequency is lower than this set value, it is CPWM modulation mode, and when it is higher than this set value, it is DPWM modulation mode. If the carrier frequency is less than or equal to 2KHz, the debugging mode is fixed as CPWM modulation.

CPWM modulation mode has large switching loss and small current ripple; DPWM modulation mode has small switching loss and large current ripple.

F8-56	PWM modulation mode		Factory value	0	Attribute	○
	Setting range	0	Asynchronous modulation			
		1	Synchronous modulation			

Under the V/F control mode, when the output frequency of the drive is high, in order to ensure the output voltage quality, synchronous modulation shall be selected, so that the carrier frequency changes with the output frequency and the carrier ratio remains unchanged.

Synchronous modulation takes effect when the operating frequency is higher than 85Hz, and the asynchronous modulation mode is fixed below 85Hz.

F8-58	Random PWM depth		Factory value	0	Attribute	○
	Setting range	0	Invalid			
		1 ~ 10	Random depth adjustment			

When the random depth adjustment is enabled, the carrier frequency output by the drive changes and adjusts within a certain range, which is beneficial to reducing external electromagnetic interference.

F8-59	Fast current limiting enabled		Factory value	1	Attribute	○
	Setting range	0	Disable			
		1	Enable			

Enable the fast current limiting function to minimize the overcurrent fault of the drive and ensure the uninterrupted operation of the drive. If the drive is in the state of fast current limiting for a long time, it may be damaged by overheating, which is not allowed. Therefore, when the drive is in the state of fast current limiting for a long time, it will report the fault E.CBC and stop.

12.10 F9 group PID function

PID control is a common method of process control. By proportional, integral and differential operation of the difference between the feedback signal of the controlled quantity and the target signal, and by adjusting the output frequency of the drive, a closed-loop system is formed to stabilize the controlled quantity at the target value.

It is suitable for process control occasions such as flow control, pressure control and temperature control. The following figure shows the principle block diagram of PID control.

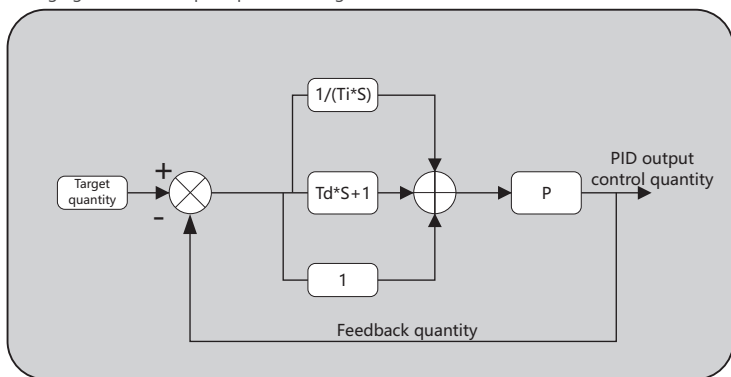

F9-00	PID set source		Factory value	0	Attribute	○
	Setting range	0	F9-01 setting			
		1	AI1			
		2	AI2			
		3	AI3			
		4	Pulse setting HDI			
		5	Communication setting			
6	Multi-segment instruction					
F9-01	PID digital setting		Factory value	50.0%	Attribute	○
	Setting range		0.0% ~ 100.0%			

This function code is used to set the target quantity set channel of process PID.

The set target quantity of process PID is a relative value, and the set range is 0.0%~100.0%. Similarly, the feedback quantity of PID is also a relative quantity, and the function of PID is to make these two relative quantities the same.

F9-02	PID feedback source		Factory value	0	Attribute	o	
	Setting range	0	AI1				
		1	AI2				
		2	AI3				
		3	AI1 - AI2				
		4	HDI pulse				
		5	Communication setting				
		6	AI1 + AI2				
		7	MAX(AI1 , AI2)				
8	MIN(AI1 , AI2)						

This parameter is used to select the feedback signal channel of the process PID.

The feedback quantity of process PID is also a relative value, and the set range is 0.0%~100.0%.

F9-03	PID effect direction		Factory value	0	Attribute	o	
	Setting range	0	Positive effect				
		1	Negative effect				

This function code is used to set the effect direction of process PID.

Positive effect: When the feedback is greater than the setting, the PID output control quantity decreases.

Negative effect: When the feedback is greater than the setting, the PID output control quantity increases.

When using this function, it is necessary to combine the influence of negative PID effect of multi-function terminal (function 35).

F9-04	PID set feedback range		Factory value	1000	Attribute	o
	Setting range		0 ~ 65535			

This function code is used for PID set displays U0-15 and U0-16.

For example, F9-04 is set to 5000, and when PID is set as 100.0%, the set display U0.15 of PID is 5000.

F9-05	Proportional gain Kp1		Factory value	20.0	Attribute	o
	Setting range		0.0 ~ 1000.0			
F9-06	Integration time Ti1		Factory value	2.00s	Attribute	o
	Setting range		0.01s ~ 10.00s			
F9-07	Differential time Td1		Factory value	0.000s	Attribute	o
	Setting range		0.00 ~ 10.000			

1) Proportional gain Kp1:

It determines the regulation strength of the whole PID regulator, and the greater Kp1, the greater the regulation strength. This parameter 100.0 indicates that when the deviation between the PID feedback quantity and the set quantity is 100.0%, the regulation amplitude of the PID regulator to the output frequency instruction is the maximum frequency.

2) Integration time Ti1:

It determines the strength of integral regulation of PID regulator. The shorter the integration time, the greater the regulation strength. The integration time means that when the deviation between the PID feedback quantity and the set quantity is 100.0%, the integral regulator continuously regulates after such time, and the regulation quantity reaches the maximum frequency.

3) Differential time Td1:

It determines the regulation strength of PID regulator on deviation change rate. The longer the differential time, the greater the regulation strength. Differential time means that when the feedback quantity changes by 100.0% during this time, the regulation quantity of differential regulator is the maximum frequency.

F9-08	PID inversion cutoff frequency		Factory value	0.00	Attribute	o
	Setting range		0.00 ~ maximum frequency			

This function code is used to set the maximum reverse PID output frequency operated by the drive.

F9-09	PID deviation limit	Factory value	0.0%	Attribute	○
	Setting range	0.0% ~ 100.0%			

This function code is used to set the minimum valid deviation of PID. When the deviation between the PID set quantity and the feedback quantity is less than F9-09, the PID will stop regulating.

F9-10	PID differential amplitude limit	Factory value	0.10%	Attribute	○
	Setting range	0.00% ~ 100.00%			

This function code is used to set the range of PID differential output, in order to prevent the system oscillation due to over-sensitive differential regulation, and limit the differential function of PID to a small range.

F9-11	PID set change time	Factory value	0.00s	Attribute	○
	Setting range	0.00s ~ 650.00s			

This function code is used to set the time required for the set value of PID to change from 0.0% to 100.0%.

When the given PID changes, the given value of PID changes linearly according to the given change time, which prevents the adverse impact on the system caused by sudden change of the given PID.

F9-12	PID feedback filtering time	Factory value	0.00s	Attribute	○
	Setting range	0.00s ~60.00s			
F9-13	PID output filtering time	Factory value	0.00s	Attribute	○
	Setting range	0.00s ~60.00s			

The above function codes are used to set PID feedback filtering and PID output filtering respectively.

PID feedback filtering is beneficial to reduce the influence of feedback being interfered, but it will lead to the decrease of response performance of process PID control system.

PID output filtering will weaken the abrupt change of drive output frequency, but it will also reduce the response performance of process PID control system.

F9-15	Proportional gain Kp2	Factory value	20.0	Attribute	○
	Setting range	0.0 ~ 1000.0			
F9-16	Integration time Ti2	Factory value	2.00s	Attribute	○
	Setting range	0.01s ~ 10.00s			
F9-17	Differential time Td2	Factory value	0.000s	Attribute	○
	Setting range	0.00 ~ 10.000			
F9-18	PID parameter switching condition	Factory value	0	Attribute	○
	Setting range	0	No switching		
		1	Switching through X terminal		
		2	Automatic switching according to deviation		
		3	Automatic switching according to operating frequency		
F9-19	PID parameter switching deviation 1	Factory value	20.0%	Attribute	○
	Setting range	0.0% ~ F9-20			
F9-20	PID parameter switching deviation 2	Factory value	80.0%	Attribute	○
	Setting range	F9-19 ~ 100.0%			

In some applications, a group of PID parameters can not meet the needs of the whole operation process, so different PID parameters need to be adopted in different situations.

This group of function codes is used to switch two groups of PID parameters. The setting mode of regulator parameters F9-15~F9-17 is similar to that of parameters F9-05~F9-07.

F9-18 function code is used to set PID parameter switching conditions.

When F9-18 is equal to 0, PID parameters are not switched.

When F9-18 is equal to 1, the function selection of multi-function terminal shall be set to 43 (PID

parameter switching terminal); When such terminal is invalid, select parameter group 1 (F9-05~F9-07), and when the terminal is valid, select parameter group 2 (F9-15~F9-17).

When F9-18 is equal to 2, if the absolute value of the deviation between setting and feedback is less than the PID parameter switching deviation 1(F9-19), select parameter group 1 for PID parameter. When the absolute value of deviation between given and feedback is greater than PID switching deviation 2(F9-20), select parameter group 2 for PID parameters. When the deviation between given and feedback is between switching deviation 1 and switching deviation 2, the PID parameter is linear interpolation value of two groups of PID parameters, as shown in the figure below.

When F9-18 is equal to 3, the PID parameter has a linear relationship with the current operating frequency, 0Hz corresponds to PID parameter 1, and the maximum output frequency corresponds to PID parameter 2.

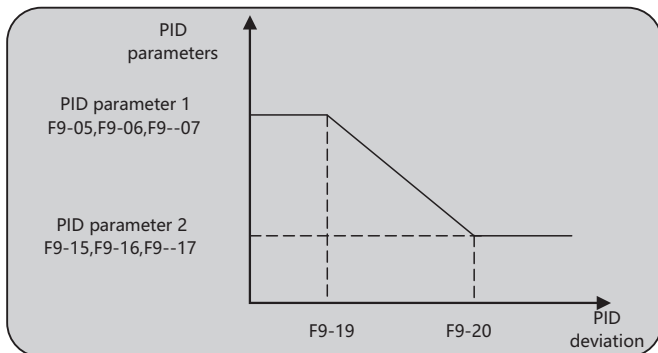

F9-21	PID initial value	Factory value	0.0%	Attribute	○
	Setting range	0.0% ~ 100.0%			
F9-22	PID initial value holding time	Factory value	0.00s	Attribute	○
	Setting range	0.00s ~ 650.00s			

After running the drive, the PID output is fixed as the initial value of PID, and after the initial value of PID is kept for running for PID initial value holding time, the PID enters the regulating operation. The schematic diagram for starting the PID initial value function of the drive is shown in the figure below.

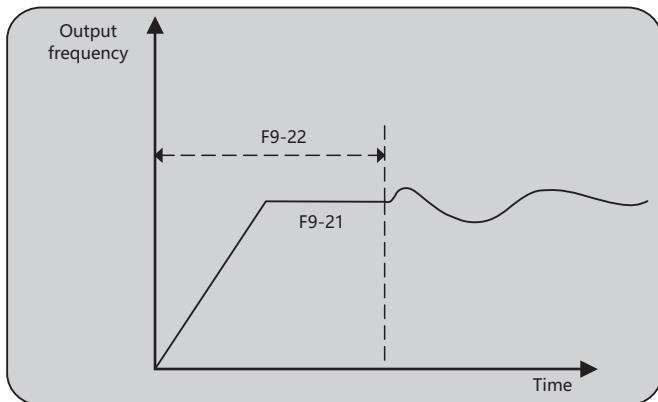

F9-23	Positive maximum value of deviation between two outputs	Factory value	1.00%	Attribute	○
	Setting range	0.00% ~ 100.00%			
F9-24	Negative maximum value of deviation between two outputs	Factory value	1.00%	Attribute	○
	Setting range	0.00% ~ 100.00%			

This group of parameters is used to limit the difference between the two PID control outputs, so as to achieve the effect of restraining the PID output from changing too fast.

F9-25	PID integral attribute		Factory value	00	Attribute	○
	Setting range	Units	Integral separation			
		0	Invalid			
		1	Valid			
		Tens	Whether to stop integrating after the output reaches the limit value			
	0	Continue integration				
1	Stop integration					

Units: It controls whether the PID integration is valid. When the multi-function terminal selection integration pause (function 38) is valid, the PID integration will stop running if the units is 1.

Tens: When set to 1, the integral calculation will be stopped after the output of PID operation reaches the maximum or minimum value, which is helpful for less PID overshoot.

F9-26	PID feedback loss detection value	Factory value	0.0%	Attribute	○
	Setting range	0.0%: feedback loss is not judged; 0.1% ~ 100.0%			
F9-27	PID feedback loss detection time	Factory value	0.0s	Attribute	○
	Setting range	0.0s ~ 20.0s			

This function code is used to set whether to detect PID feedback loss.

When the PID feedback quantity is less than the F9-26 feedback loss detection value, and the duration is longer than the F9-27 set time, the drive will report "E.FBL" feedback loss fault.

F9-28	PID stop operation		Factory value	0	Attribute	○
	Setting range	0	Stop without operation			
		1	Stop with operation			

This function code is used to set whether the PID will continue to operate when the machine is stopped. In general, PID stops operation in stop state.

F9-29	PID overshoot detection value	Factory value	0.0%	Attribute	○
	Setting range	0.0%: feedback overshoot is not judged; 0.1% ~ 100.0%			
F9-30	PID overshoot detection time	Factory value	0.0s	Attribute	○
	Setting range	0.0s ~ 20.0s			

This function code is used to set whether to detect PID feedback overshoot.

When the PID feedback quantity is greater than F9-29 feedback overshoot detection value, and the duration is greater than F9-30 set time, the drive reports "E.FBH" feedback overshoot fault.

F9-34	Set length	Factory value	1000m	Attribute	○
	Setting range	0m ~ 65535m			
F9-35	Actual length	Factory value	0m	Attribute	○
	Setting range	0m ~ 65535m			
F9-36	Pulse number per meter	Factory value	100.0	Attribute	○
	Setting range	0.1 ~ 6553.5			

The above function codes are used for fixed-length control.

The length information needs to be acquired through the multi-function digital input terminal, and the actual length F9-35 can be calculated by dividing the number of pulses sampled by the terminal with the number of pulses per meter F9-36. When the actual length is greater than the set length F9-34, the multi-function digital "length reached" ON signal will be output.

In the process of fixed length control, the length can be reset through the multi-function X terminal (the X function is selected as 28). Please refer to F5-00~F5-04 for details.

In application, it is necessary to set the corresponding input terminal function as "length count input" (function 27), and HDI port must be used when the pulse frequency is high.

F9-37	Set count value	Factory value	1000	Attribute	○
	Setting range		0 ~ 65535		
F9-38	Designated count value	Factory value	1000	Attribute	○
	Setting range		0 ~ 65535		

Count value needs to be acquired through multi-function digital input terminals. In application, it is necessary to set the corresponding input terminal function as "counter input" (function 25), and HDI port must be used when the pulse frequency is high.

When the count value reaches the set count value F9-37, the multi-function digital "set count value reached" ON signal will be output, and then the counter will stop counting.

When the count value reaches the designated count value F9-38, the multi-function digital "designated count value reached" ON signal will be output, and the counter will continue to count until the "set count value".

The specified count value F9-38 shall not be greater than the set count value F9-37. The following figure is a schematic diagram of the functions of set count value reached and designated count value reached.

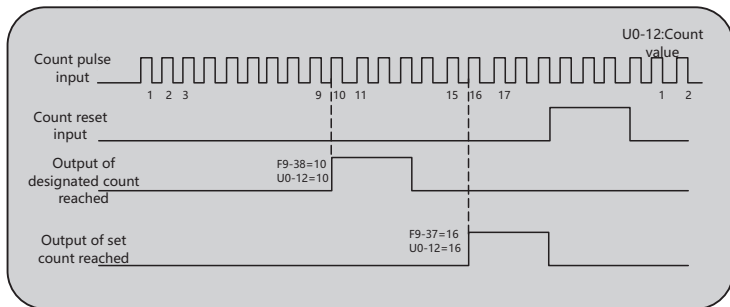

12.11 FA group multi-segment instruction, simple PLC function

The multi-segment instruction of NVF7 has more functions than the usual multi-speed. In addition to realizing the multi-speed function, it can also be used as the voltage source of VF separation and the set source of process PID. The dimension of multi-segment instruction is relative value.

FA-00	Multi-segment instruction 0	Factory value	0.0%	Attribute	○
	Setting range		-100.0% ~ 100.0%		
FA-01	Multi-segment instruction 1	Factory value	0.0%	Attribute	○
	Setting range		-100.0% ~ 100.0%		
FA-02	Multi-segment instruction 2	Factory value	0.0%	Attribute	○
	Setting range		-100.0% ~ 100.0%		
FA-03	Multi-segment instruction 3	Factory value	0.0%	Attribute	○
	Setting range		-100.0% ~ 100.0%		

FA-04	Multi-segment instruction 4	Factory value	0.0%	Attribute	○
	Setting range		-100.0% ~ 100.0%		
FA-05	Multi-segment instruction 5	Factory value	0.0%	Attribute	○
	Setting range		-100.0% ~ 100.0%		
FA-06	Multi-segment instruction 6	Factory value	0.0%	Attribute	○
	Setting range		-100.0% ~ 100.0%		
FA-07	Multi-segment instruction 7	Factory value	0.0%	Attribute	○
	Setting range		-100.0% ~ 100.0%		
FA-08	Multi-segment instruction 8	Factory value	0.0%	Attribute	○
	Setting range		-100.0% ~ 100.0%		
FA-09	Multi-segment instruction 9	Factory value	0.0%	Attribute	○
	Setting range		-100.0% ~ 100.0%		
FA-10	Multi-segment instruction 10	Factory value	0.0%	Attribute	○
	Setting range		-100.0% ~ 100.0%		
FA-11	Multi-segment instruction 11	Factory value	0.0%	Attribute	○
	Setting range		-100.0% ~ 100.0%		
FA-12	Multi-segment instruction 12	Factory value	0.0%	Attribute	○
	Setting range		-100.0% ~ 100.0%		
FA-13	Multi-segment instruction 13	Factory value	0.0%	Attribute	○
	Setting range		-100.0% ~ 100.0%		
FA-14	Multi-segment instruction 14	Factory value	0.0%	Attribute	○
	Setting range		-100.0% ~ 100.0%		
FA-15	Multi-segment instruction 15	Factory value	0.0%	Attribute	○
	Setting range		-100.0% ~ 100.0%		

Multi-segment instruction can be used in three occasions: as a frequency source, as a voltage source for VF separation, and as a setting source for process PID. In these three applications, the dimension of multi-segment instruction is relative value, ranging from -100.0% to 100.0%. When it is used as a frequency source, it is the percentage of relative maximum frequency; When it is used as a voltage source for VF separation, it is the percentage relative to the rated voltage of the motor; However, because the PID setting is a relative value, multi-segment instruction as the PID setting source does not require dimension conversion.

Multi-segment instructions need to be switched and selected according to the different states of the multi-function digital X. For details, please refer to the related instructions in F5 group.

FA-16	Simple PLC running mode	Factory value	0	Attribute	○
	Setting range	0	Stop at the end of single running		
		1	Keep the final value at the end of single running		
		2	Keep circulating		

The simple PLC function has two functions, as a frequency source or a voltage source for VF separation.

The following figure is a schematic diagram when PLC is used as a frequency source. When the simple PLC is used as a frequency source, the multi-segment frequency N is used as a frequency source, and the positive and negative of FA-00~FA-15 determines the running direction. If it is negative, it means that the drive runs in the reverse direction.

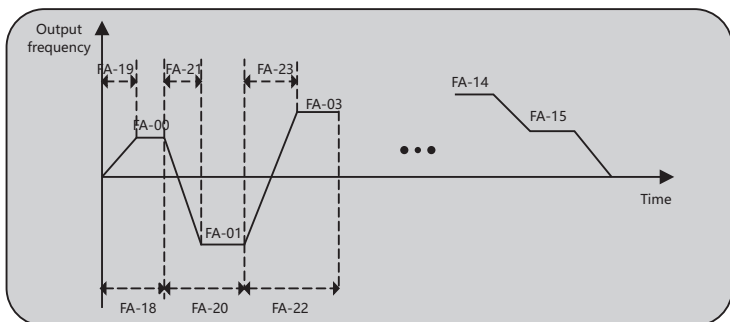

As a frequency source, PLC has three operation modes, which are not available as a voltage source for VF separation. Where:

0: Stop at the end of single running

The drive automatically stops after completing a single cycle, and will be restarted only after waiting for the next startup command.

1: Keep the final value at the end of single running

After completing a cycle, the drive will keep the operating frequency and direction at the final moment.

2: Keep circulating

After completing a cycle, the drive will automatically start the next cycle.

FA-17	Simple PLC power-off memory selection		Factory value	00	Attribute	○
	Setting range	Units	Power-off memory selection			
		0	No power-off memory			
		1	Power-off memory			
		Tens	Stop memory selection			
		0	No stop memory			
1	Stop memory					

Power-off memory of PLC refers to the memory of the operation stage and operating frequency of PLC before power-off, and the drive will continue to run from the memory stage when it is powered on next time. If no memory is selected, the PLC process will be restarted every time powered on.

The PLC stop memory refers to recording the previous PLC operation stage and operating frequency when it is stopped, and continuing to run from the memory stage when it runs next time. If no memory is selected, the PLC process will be restarted every time it is started.

FA-18	Running time of simple PLC segment 0		Factory value	0.0s(h)	Attribute	○
	Setting range		0.0s(h) ~ 6500.0s(h)			
FA-19	Selection of acceleration and deceleration time in simple PLC segment 0		Factory value	0	Attribute	○
	Setting range	0	Acceleration and deceleration time 1			
		1	Acceleration and deceleration time 2			
		2	Acceleration and deceleration time 3			
		3	Acceleration and deceleration time 4			
FA-20	Running time of simple PLC segment 1		Factory value	0.0s(h)	Attribute	○
	Setting range		0.0s(h) ~ 6500.0s(h)			

FA-21	Selection of acceleration and deceleration time in simple PLC segment 1	Factory value	0	Attribute	○
	Setting range	Same as FA-19			
FA-22	Running time of simple PLC segment 2	Factory value	0.0s(h)	Attribute	○
	Setting range	0.0s(h) ~ 6500.0s(h)			
FA-23	Selection of acceleration and deceleration time in simple PLC segment 2	Factory value	0	Attribute	○
	Setting range	Same as FA-19			
FA-24	Running time of simple PLC segment 3	Factory value	0.0s(h)	Attribute	○
	Setting range	0.0s(h) ~ 6500.0s(h)			
FA-25	Selection of acceleration and deceleration time in simple PLC segment 3	Factory value	0	Attribute	○
	Setting range	Same as FA-19			
FA-26	Running time of simple PLC segment 4	Factory value	0.0s(h)	Attribute	○
	Setting range	0.0s(h) ~ 6500.0s(h)			
FA-27	Selection of acceleration and deceleration time in simple PLC segment 4	Factory value	0	Attribute	○
	Setting range	Same as FA-19			
FA-28	Running time of simple PLC segment 5	Factory value	0.0s(h)	Attribute	○
	Setting range	0.0s(h) ~ 6500.0s(h)			
FA-29	Selection of acceleration and deceleration time in simple PLC segment 5	Factory value	0	Attribute	○
	Setting range	Same as FA-19			
FA-30	Running time of simple PLC segment 6	Factory value	0.0s(h)	Attribute	○
	Setting range	0.0s(h) ~ 6500.0s(h)			
FA-31	Selection of acceleration and deceleration time in simple PLC segment 6	Factory value	0	Attribute	○
	Setting range	Same as FA-19			
FA-32	Running time of simple PLC segment 7	Factory value	0.0s(h)	Attribute	○
	Setting range	0.0s(h) ~ 6500.0s(h)			
FA-33	Selection of acceleration and deceleration time in simple PLC segment 7	Factory value	0	Attribute	○
	Setting range	Same as FA-19			
FA-34	Running time of simple PLC segment 8	Factory value	0.0s(h)	Attribute	○
	Setting range	0.0s(h) ~ 6500.0s(h)			

FA-35	Selection of acceleration and deceleration time in simple PLC segment 8	Factory value	0	Attribute	○
	Setting range	Same as FA-19			
FA-36	Running time of simple PLC segment 9	Factory value	0.0s(h)	Attribute	○
	Setting range	0.0s(h) ~ 6500.0s(h)			
FA-37	Selection of acceleration and deceleration time in simple PLC segment 9	Factory value	0	Attribute	○
	Setting range	Same as FA-19			
FA-38	Running time of simple PLC segment 10	Factory value	0.0s(h)	Attribute	○
	Setting range	0.0s(h) ~ 6500.0s(h)			
FA-39	Selection of acceleration and deceleration time in simple PLC segment 10	Factory value	0	Attribute	○
	Setting range	Same as FA-19			
FA-40	Running time of simple PLC segment 11	Factory value	0.0s(h)	Attribute	○
	Setting range	0.0s(h) ~ 6500.0s(h)			
FA-41	Selection of acceleration and deceleration time in simple PLC segment 11	Factory value	0	Attribute	○
	Setting range	Same as FA-19			
FA-42	Running time of simple PLC segment 12	Factory value	0.0s(h)	Attribute	○
	Setting range	0.0s(h) ~ 6500.0s(h)			
FA-43	Selection of acceleration and deceleration time in simple PLC segment 12	Factory value	0	Attribute	○
	Setting range	Same as FA-19			
FA-44	Running time of simple PLC segment 13	Factory value	0.0s(h)	Attribute	○
	Setting range	0.0s(h) ~ 6500.0s(h)			
FA-45	Selection of acceleration and deceleration time in simple PLC segment 13	Factory value	0	Attribute	○
	Setting range	Same as FA-19			
FA-46	Running time of simple PLC segment 14	Factory value	0.0s(h)	Attribute	○
	Setting range	0.0s(h) ~ 6500.0s(h)			
FA-47	Selection of acceleration and deceleration time in simple PLC segment 14	Factory value	0	Attribute	○
	Setting range	Same as FA-19			
FA-48	Running time of simple PLC segment 15	Factory value	0.0s(h)	Attribute	○
	Setting range	0.0s(h) ~ 6500.0s(h)			

FA-49	Selection of acceleration and deceleration time in simple PLC segment 15		Factory value	0	Attribute	○
	Setting range		Same as FA-19			
FA-50	Simple PLC running time unit		Factory value	0	Attribute	○
	Setting range	0	S (second)			
1		H (hour)				
FA-51	Multi-segment instruction 0 set mode		Factory value	0	Attribute	○
	Setting range	0	Function code FA-00 setting			
		1	AI1			
		2	AI2			
		3	AI3			
		4	HDI pulse			
		5	PID			
6	Preset frequency (F0-08) setting, and UP/DOWN modifiable					

This function code is used to set the set channel of multi-segment instruction 0.

Besides FA-00, there are many other options for multi-segment instruction 0, which is convenient to switch between multi-segment instruction and other set modes. When multi-segment instruction is used as frequency source or simple PLC is used as frequency source, the switching between the two frequency sources can be easily realized.

12.12 FB group communication parameters

Fb-00	Communication protocol selection		Factory value	0	Attribute	●
	Setting range	0	MODBUS-RTU protocol			
1		Profibus-DP, Profinet, CANopen, EtherCAT protocols				

The drive uses serial port to realize MODBUS, Profinet, CANopen and EtherCAT protocols, and only one of these protocols can be used at the same time. Please set this parameter correctly according to actual needs.

Fb-01	Communication baud rate		Factory value	5005	Attribute	○
	Setting range	Units	modbus			
		0	300Bps			
		1	600Bps			
		2	1200Bps			
		3	2400Bps			
		4	4800Bps			
		5	9600Bps			
		6	19200Bps			
		7	38400Bps			
		8	57600Bps			
		9	115200Bps			
		Tens	Profibus DP, Profinet			
		0	115200Bps			
		1	208300Bps			
		2	256000Bps			
		3	512000Bps			
		Hundreds	Reserved			
		Thousands	Reserved			

This parameter is used to set the data transmission rate between the upper computer and the drive. Note that the baud rates set by the upper computer and the drive must be consistent, otherwise communication cannot be carried out. The higher the baud rate, the higher the communication speed.

Units: set modbus communication baud rate as standard for drive;Tens:set the communication baud rate on the expansion board.

Fb-02	MODBUS data format		Factory value	0	Attribute	o
	Setting range		0	No check (8-N-2)		
		1	Even check (8-E-1)			
		2	Odd check (8-O-1)			
		3	No check (8-N-1)			

In MODBUS communication mode, the data formats set by the upper computer and the drive must be consistent, otherwise, communication cannot be carried out.

8-N-2: 8 data bits, no parity bit, 2 stop bits

8-E-1: 8 data bits, even parity bit, 1 stop bit

8-O-1: 8 data bits, odd parity bit, 1 stop bit

8-N-1: 8 data bits, no parity bit, 1 stop bits

Fb-03	Local address		Factory value	1	Attribute	o
		Setting range		1 ~ 247		

The local address is unique (except the broadcast address), which is the basis for realizing point-to-point communication between the upper computer and the drive. When the address sent by the master is 0, it is a broadcast address, and the slave does not need to return data after receiving the broadcast instruction.

Fb-04	MODBUS response delay		Factory value	2ms	Attribute	o
		Setting range		0 ~ 20ms		

Response delay: refers to the interval between the end of data reception of the drive and the sending of data to the upper computer. If the response delay is less than the system processing time, the response delay will be subject to the system processing time; If the response delay is longer than the system processing time, the system will wait until the response delay time is up before sending data to the upper computer.

This parameter is the response delay set for MODBUS communication.

Fb-05	MODBUS communication timeout		Factory value	0.0s	Attribute	o
		Setting range		0.0 ~ 60.0s		

When the function code is set to 0.0s, the communication timeout parameter is invalid. When this function code is set to a valid value, if the interval between one communication and the next communication exceeds the communication timeout, the system will report a communication failure error (E.CE), which is usually set to be invalid.

Fb-06	Data transmission format		Factory value	1	Attribute	o	
	Setting range	Units	Modbus				
		0	Non-standard Modbus protocol				
		1	Standard Modbus protocol				

Non-standard Modbus protocol and standard Modbus protocol have the following differences when returning communication error codes and read data instructions:

Return communication error code			Return read data instruction		
Byte	Non-standard	Standard	Byte	Non-standard	Standard
0	Slave address	Slave address	0	Slave address	Slave address
1	Function code	0x80+ function code	1	Function code	Function code
2	0x80	Error code	2	Number of data bytes high byte	Number of data bytes
3	0x01	CRC low byte	3	Number of data bytes low byte	Return data N bytes
4	0x00	CRC high byte	4	Return data N bytes	CRC low byte
5	Error code		5	CRC low byte	CRC high byte
6	CRC low byte		6	CRC high byte	
7	CRC high byte		7		

Fb-07	Communication current resolution		Factory value	0	Attribute	○
	Setting range		0	0.01A		
			1	0.1A		

When Modbus communication reads the U0-04 output current, the resolution of the read data can be modified by this parameter. When using the extended communication card to communicate, the read current data is fixed at 0.1A resolution.

Fb-09	Interruption detection time for optional card communication		Factory value	0.0s	Attribute	○
	Setting range		0.0 ~ 60.0s			

When the function code is set to 0.0s, the communication interruption detection parameter is invalid. When this function code is set to a valid value, if the interval between one communication and the next communication exceeds the interruption detection time, the system will report a communication failure error (E.CE), which is usually set to be invalid.

12.13 Fd group optional card

Fd-00	Number of encoder lines		Factory value	1024	Attribute	●
	Setting range		1 ~ 65535			

Set the number of pulses per revolution of ABZ or UVW incremental encoder. In the flux vector control mode, the number of encoder pulses must be set correctly, otherwise the motor will run abnormally.

Fd-01	Encoder type		Factory value	0	Attribute	●
	Setting range	0	ABZ incremental encoder			
		2	Resolver			

After the PG card is installed, the encoder type shall be selected correctly according to the actual situation, otherwise the drive may not operate properly.

Fd-03	ABZ incremental encoder AB phase sequence		Factory value	0	Attribute	●
	Setting range	0	Forward			
		1	Reverse			

This function code is only valid for ABZ incremental encoder, that is, it is only valid when Fd-01=0. It is used to set the phase sequence of AB signal of ABZ incremental encoder.

This function code is effective for asynchronous motor, and the AB phase sequence of ABZ encoder can be obtained when asynchronous motor is dynamically tuned.

Fd-07	Pole pairs of resolver		Factory value	1	Attribute	●
	Setting range		1 ~ 65535			

The resolver has polar logarithm, and when using this encoder, the parameters of polar logarithm must be set correctly.

Fd-09	PG disconnection detection time	Factory value	0.0s	Attribute	⊙
	Setting range	0.0s ~ 10.0s			

It is used to set the detection time of encoder disconnection fault. When it is set to 0.0s, the drive will not detect encoder disconnection fault. When the drive detects the disconnection fault, and the duration exceeds the set time of this parameter, the drive will give the alarm E.ENCD.

12.14 FE group fault and protection

FE-00	Motor overload protection selection	Factory value	1	Attribute	○
	Setting range	0	Prohibit motor overload protection function		
		1	Enable motor overload protection function		
FE-01	Motor overload protection gain	Factory value	1.00	Attribute	○
	Setting range	0.20 ~ 10.00			
FE-02	Motor overload warning coefficient	Factory value	80%	Attribute	○
	Setting range	50% ~ 100%			

In order to effectively protect different load motors, it is necessary to set the motor overload protection gain according to the motor overload capacity. Motor overload protection is an inverse time curve, and the motor overload protection curve is shown in the following figure:

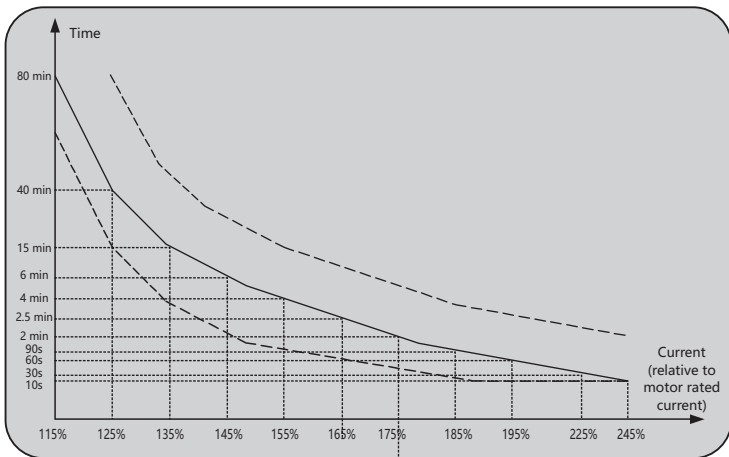

As shown in the figure, the motor overload protection time corresponding to the marked running current and the time between two points are obtained by linear calculation.

Example: At 145% current, the time for reporting OL1 is 6 minutes; At 155% current, the time for reporting OL1 is 4 minutes, then at 150% current, the time for reporting OL1 time is

$$T = 6 + (4 - 6) \cdot (150\% - 145\%) / (155\% - 145\%) = 5 \text{ (minutes)}$$

Motor overload protection gain:

When the overload protection gain is set to 1.00 by default, when the motor running current reaches 175% of the motor rated current, it will be report motor overload (OL1) after continuous running for 2 minutes; When the running current of the motor reaches 115% of the rated current of the motor, it will report motor overload (OL1) after continuous running for 80 minutes.

If it is necessary to modify the overload time according to the motor, adjust the parameters.

Example: the rated current of the motor is 100A. When FE-01=1.00, when the drive runs to 125A (125%) and lasts for 40 minutes, it will report OL1 fault.

If you want the drive to report OL1 fault after running at 125A for 50 minutes, set FE-01=1.25, 40 * 1.25 =50 minutes.

If you want the drive to report OL1 fault after running at 125A for 20 minutes, set FE-01=0.5, 40 * 0.5= 20 minutes.

Note: The maximum time for overload is 80 minutes and the minimum time is 10 seconds.

Motor overload warning coefficient:

The motor overload warning function is used to give a warning signal to the control system through DO or relay before motor overload fault protection. This warning coefficient is used to determine how much earlier the warning shall be given before motor overload protection. The larger this value is, the less in advance the warning shall be. When the accumulated output current of the drive is greater than the product of overload time (the value of the inverse time limit curve of motor overload protection) and "motor overload warning coefficient (FE-02)", the multi-function digital DO of the drive outputs a valid signal of "motor overload warning". Under special circumstances, when the motor overload warning coefficient FE-02 is set to 100%, the early amount of warning is 0, and the warning and overload protection occur at the same time.

FE-03	Overvoltage stall gain	Factory value	30	Attribute	○
	Setting range	0 ~ 100			
FE-04	Overvoltage stall action voltage	Factory value	Model determination	Attribute	⊙
	Setting range	380V model: 650.0V~800.0V 220V model: 320.0V~800.0V			

Parameter FE-03 has the same function as parameter F4-24, and parameter FE-04 has the same function as parameter F4-22. Please refer to F4 group parameters for details.

Note: To enable the overvoltage stall function, F4-23 shall be set to 1: Valid.

FE-07	Selection of short-circuit protection to ground		Factory value	1	Attribute	○
	Setting range	Units	Selection of power-on short-circuit protection to ground			
		0	Invalid			
		1	Valid			
		Tens	Selection of short-circuit protection to ground before operation			
		0	Invalid			
1	Valid					

Selection of power-on short-circuit protection to ground:

Every time the drive is powered on, the drive detects whether the motor has a short circuit fault to the ground.

Selection of short circuit protection to ground before operation:

Before each operation of the drive, first detect whether the motor has a short circuit fault to the ground, and then start operation properly if there is no such fault.

FE-08	Starting voltage of braking unit action	Factory value	Model determination	Attribute	○
	Setting range	380V model: 650.0V~800.0V 220V model: 320.0V~800.0V			

The starting voltage Vbreak of the built-in braking unit is set as follows:

$$(1.414V_s+30) \leq V_{\text{break}} \leq 800$$

Vs: AC power supply voltage of input drive

Note: Improper setting of this voltage may lead to abnormal operation of the built-in braking unit!

FE-09	Fault automatic reset times	Factory value	0	Attribute	○
	Setting range	0 ~ 30			
FE-10	During fault automatic reset Fault DO action selection	Factory value	1	Attribute	○
	Setting range	0	No action		
		1	Action		
FE-11	Automatic reset interval of fault	Factory value	6.0s	Attribute	○
	Setting range	0.1s ~ 100.0s			

Fault automatic reset times:

Set the number of times that can be reset automatically. After this number is exceeded, the drive will no longer automatically reset the fault. Setting it to 0 means that the automatic fault reset function is not enabled.

Automatic reset DO action selection:

If the drive turns on the fault automatic reset function, this parameter can be used to set whether the fault DO relay acts during the fault reset.

Automatic reset interval:

The waiting time for fault automatic reset after the drive reports a fault.

FE-12	Selection of input open-phase/contactor connection protection	Factory value	11	Attribute	○
	Setting range	Units	Input open-phase protection selection		
		0	Input open-phase protection disabled		
		1	Simultaneous detection of software and hardware input open-phase condition protection		
		2	Software input open-phase protection		
		3	Hardware input open-phase protection		
		Tens	Contactor connection protection selection		
		0	Disable		
1		Enable			

Input open-phase protection selection:

Hardware input open-phase protection and software input open-phase protection can be selected for input open-phase protection. When software protection is selected, the sensitivity of software input open-phase protection can be adjusted by parameters FE-74 and FE-75.

Contactor connection protection selection:

This function is used to judge whether the starting resistor contactor is connected. If the drive is operated with load while the starting resistor relay is not connected, it will lead to serious heating of the starting resistor or even burning of the starting resistor. It is recommended that this function keep allowing protection options.

FE-13	Output open-phase protection selection	Factory value	01	Attribute	○
	Setting range	Units	Output open-phase protection selection		
		0	Disable		
		1	Enable		
		Tens	Selection of output open-phase protection before operation		
		0	Disable		
1		Enable			

Selection of output open-phase protection:

Select whether to protect the output open-phase. If you select not to protect the output open-phase, the actual drive output current will be distorted and even oscillate.

Selection of output open-phase protection before operation:

If this function is enabled, the drive will send out a DC signal before each operation to detect whether the output is with open-phase.

FE-14	Type of the first fault	Factory value	0	Attribute	●
	Setting range		0 ~ 99		
FE-15	Type of the second fault	Factory value	0	Attribute	●
	Setting range		0 ~ 99		
FE-16	Type of the third fault	Factory value	0	Attribute	●
	Setting range		0 ~ 99		

The third fault is the latest fault, the second fault is the previous fault, and the first fault is the previous two faults. Please refer to the relevant part of fault analysis for the meaning of fault codes, possible causes of faults and solutions.

Last fault state					
FE-17	Frequency at the third fault	Factory value	0	Attribute	●
	Setting range		0.00Hz ~ 655.35Hz		
FE-18	Current at the third fault	Factory value	0	Attribute	●
	Setting range		0.00A ~ 655.35A		
FE-19	Bus voltage at the third fault	Factory value	0	Attribute	●
	Setting range		0.0V ~ 6553.5V		
FE-20	Input terminal state at the third fault	Factory value	0	Attribute	●
	Setting range		0 ~ 9999		
FE-21	Output terminal state at the third fault	Factory value	0	Attribute	●
	Setting range		0 ~ 9999		
FE-22	Drive state at the third fault	Factory value	0	Attribute	●
	Setting range		0 ~ 65535		
FE-23	Power-on time of drive at the third fault	Factory value	0	Attribute	●
	Setting range		0s ~ 65535s		
FE-24	Running time of drive at the third fault	Factory value	0	Attribute	●
	Setting range		0.0s ~ 6553.5s		
Previous fault state					
FE-27	Frequency at the second fault	Factory value	0	Attribute	●
	Setting range		0.00Hz ~ 655.35Hz		
FE-28	Current at the second fault	Factory value	0	Attribute	●
	Setting range		0.00A ~ 655.35A		
FE-29	Bus voltage at the second fault	Factory value	0	Attribute	●
	Setting range		0.0V ~ 6553.5V		
FE-30	Input terminal state at the second fault	Factory value	0	Attribute	●
	Setting range		0 ~ 9999		
FE-31	Output terminal state at the second fault	Factory value	0	Attribute	●
	Setting range		0 ~ 9999		
FE-32	Drive state at the second fault	Factory value	0	Attribute	●
	Setting range		0 ~ 65535		
FE-33	Power-on time of drive at the second fault	Factory value	0	Attribute	●
	Setting range		0s ~ 65535s		
FE-34	Running time of drive at the second fault	Factory value	0	Attribute	●
	Setting range		0.0s ~ 6553.5s		

First two fault states					
FE-37	Frequency at the first fault	Factory value	0	Attribute	●
	Setting range	0.00Hz ~ 655.35Hz			
FE-38	Current at the first fault	Factory value	0	Attribute	●
	Setting range	0.00A ~ 655.35A			
FE-39	Bus voltage at the first fault	Factory value	0	Attribute	●
	Setting range	0.0V ~ 655.3V			
FE-40	Input terminal state at the first fault	Factory value	0	Attribute	●
	Setting range	0 ~ 9999			
FE-41	Output terminal state at the first fault	Factory value	0	Attribute	●
	Setting range	0 ~ 9999			
FE-42	Drive state at the first fault	Factory value	0	Attribute	●
	Setting range	0 ~ 65535			
FE-43	Power-on time of drive at the first fault	Factory value	0	Attribute	●
	Setting range	0s ~ 65535s			
FE-44	Running time of drive at the first fault	Factory value	0	Attribute	●
	Setting range	0.0s ~ 6553.5s			

Input terminal state in case of fault:

Display X state, and convert it into binary correspondence (1 for high level, 0 for low level)

Bit0 – X1; Bit1 – X2; Bit2 – X3; Bit3 – X4; Bit4 – HDI;

Output terminal state in case of fault:

Display DO state, and convert it into binary correspondence (1 for high level, 0 for low level)

Bit0 – HDO; Bit1 – Relay1; Bit2 – Reserved; Bit3 – Relay2; Bit4 – Reserved;

Drive state in case of fault:

Display the operating state information of the drive and convert it into a binary correspondence table

Bit 1: Bit0 – 0: Stop, 1: Forward; 2: Reverse

Bit 3: Bit2 – 0: Constant speed, 1: Acceleration; 2: Deceleration

Bit4 – 0: Bus voltage is normal; 1: Undervoltage

Power-on time of drive in case of fault:

Power-on time of current fault (non-cumulative power-on time)

Running time of drive in case of fault:

Running time of current fault (non-cumulative running time)

FE-47	Fault protection action selection 1		Factory value	0	Attribute	○
	Setting range	Units	Motor overload			
0		Free stop				
1		Stop by stopping mode				
2		Continue running				
Tens		Input open-phase (same as units)				
Hundreds		Output open-phase (same as units)				
Thousands		External fault (same as units)				
Ten thousands	Communication exception (same as units)					

FE-48	Fault protection action selection 2		Factory value	0	Attribute	○
	Setting range	Units	Encoder/PG card is abnormal			
		0	Free stop			
		Tens	Abnormality in parameter reading and writing			
		0	Free stop			
		1	Stop by stopping mode			
		Hundreds	Run-time PID feedback overshoot (same as FE-47 units)			
		Thousands	External fault (same as FE-47 units)			
Ten thousands	Communication exception (same as FE-47 units)					
FE-49	Fault protection action selection 3		Factory value	0	Attribute	○
	Setting range	Units	User-defined fault 1 (same as FE-47 units)			
		Tens	User-defined fault 2 (same as FE-47 units)			
		Hundreds	Power-on time reached fault (same as FE-47 units)			
		Thousands	Unloading fault			
		0	Free stop			
		1	Stop by deceleration			
		2	Directly jump to 7% of the rated frequency of the motor to continue running, and automatically return to the set frequency when not unloading			
Ten thousands	Run-time PID feedback loss (same as FE-47 units)					
FE-50	Fault protection action selection 4		Factory value	0	Attribute	○
	Setting range	Units	Excessive speed deviation (same as FE-47 units)			
		Tens	Motor overspeed (same as FE-47 units)			
		Hundreds	Initial position error (same as FE-47 units)			

The above parameters are used to set the execution mode when the drive has a corresponding fault.

When "free stop" is selected, the drive displays E.xxx and stops directly.

When "stop by stopping mode" is selected, the drive displays A.xxx, and stops by stopping mode, and displays E.xxx after stopping.

When "continue running" is selected, the drive continues to run and display A.xxx, and the operating frequency is set by FE-54.

FE-54	Selection of continuous operating frequency in case of fault		Factory value	0	Attribute	○
	Setting range	0	Run at the current operating frequency			
		1	Run at the set frequency			
		2	Run at the upper limiting frequency			
		3	Run at the lower limiting frequency			
4	Run at abnormal standby frequency					
FE-55	Abnormal standby frequency		Factory value	100.0%	Attribute	○
	Setting range		0.0% ~ 100.0% (100.0% for the maximum frequency)			

When a fault occurs during running of the drive, and the handling mode of the fault is set to continue to run, the drive displays A.xxx and runs at the frequency determined by FE-54.

When the abnormal standby frequency is selected for running, the value set by FE-55 is the percentage relative to the maximum frequency.

FE-56	Motor temperature sensor type		Factory value	0	Attribute	○
	Setting range	0	No temperature sensor			
		1	PT100			
		2	PT1000			
		3	PTC			
FE-57	Motor overheat protection threshold		Factory value	110°C	Attribute	○
	Setting range		0°C ~ 200°C			
FE-58	Motor overheat pre-alarm threshold		Factory value	90°C	Attribute	○
	Setting range		0°C ~ 200°C			

If it is necessary to monitor the motor temperature, it is necessary to connect the temperature sensor to the analog input AI3 of the drive optional card. PT100, PT1000, and PTC temperature sensors are supported, and FE-56 is set according to the type of connected sensor. The real-time temperature value of the motor can be viewed in U0-34.

When the motor temperature exceeds the motor overheat protection threshold FE-57, the drive reports E.OH2 fault.

When the motor temperature exceeds the motor overheat pre-alarm threshold FE-58, the drive multi-function digital DO or relay outputs the motor overheat pre-alarm ON signal (DO or relay terminal function is set to 39: Motor overheat alarm).

FE-59	Selection of instantaneous stop failure function		Factory value	0	Attribute	⊙
	Setting range	0	Invalid			
		1	Bus voltage constant control			
		2	Stop by deceleration			
FE-60	Recovery voltage for instantaneous stop failure		Factory value	85%	Attribute	⊙
	Setting range		80% ~ 100%			
FE-61	Recovery voltage judgment time		Factory value	0.5s	Attribute	⊙
	Setting range		0.0s ~ 100.0s			
FE-62	Judgment voltage of instantaneous stop failure action		Factory value	80%	Attribute	⊙
	Setting range		60% ~ 100%			
FE-63	Instantaneous stop gain Kp		Factory value	40	Attribute	○
	Setting range		0 ~ 100			
FE-64	Instantaneous stop integration Ki		Factory value	30	Attribute	○
	Setting range		0 ~ 100			
FE-65	Deceleration time of instantaneous stop failure		Factory value	20.0s	Attribute	⊙
	Setting range		0.0s ~ 300.0s			

When the bus voltage drops below the "judgment voltage of instantaneous stop failure action", the instantaneous stop failure process takes effect, and the output frequency of the drive automatically drops, so that the motor is in the power generation state. The instantaneous stop failure function can feed back the electric energy to the bus, keep the bus voltage around the "judgment voltage of instantaneous stop failure action" and decelerate the system to 0Hz properly. As shown in the figure below:

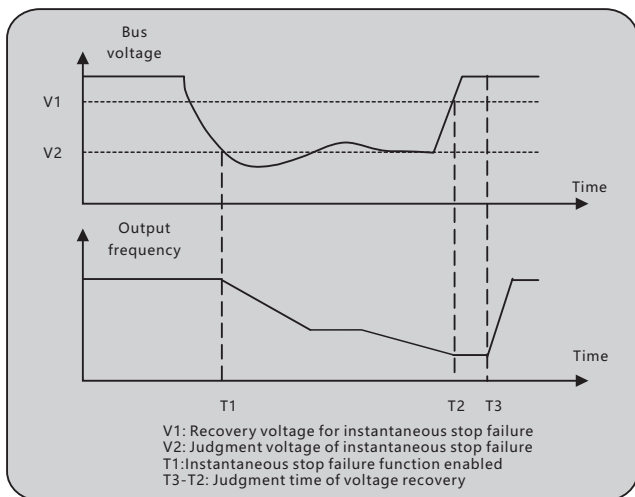

The purpose of instantaneous stop failure is to ensure that the motor can stop by deceleration properly when the power supply of the power grid is abnormal, so that the motor can be started immediately after the power supply of the power grid is restored, and it will not stop freely because of the sudden undervoltage fault of the motor when the power supply of the power grid is abnormal (in a large inertia system, it takes a long time for the motor to stop freely, and when the power supply of the power grid is restored, as the motor is still rotating at high speed, it is easy to cause overload or overcurrent fault of the drive when the motor is started).

Bus voltage constant control:

In case of instantaneous stop failure action, the drive will adjust the output frequency through the PI loop to keep the bus voltage at the "judgment voltage of instantaneous stop failure action". When the power supply of the power grid is restored, the output frequency of the drive continues to run to the target frequency.

Stop by deceleration control:

In case of instantaneous stop failure action, the drive will adjust the output frequency through the PI loop to keep the bus voltage at the "judgment voltage of instantaneous stop failure action". When the power supply of the power grid is restored, the drive will continue to decelerate to 0Hz and stop until the drive sends out the start command again.

	Unloading protection selection		Factory value	0	Attribute	o
FE-66	Setting range	0	Invalid			
		1	Valid			
FE-67	Unloading detection level		Factory value	10.0%	Attribute	o
	Setting range		0.0% ~ 100.0%			
FE-68	Unloading detection time		Factory value	1.0s	Attribute	o
	Setting range		0.0s ~ 60.0s			

If the unloading protection function is valid, then, if the output current of the drive is less than the unloading detection level FE-67 for a duration longer than the unloading detection time FE-68, when selecting to continue running during unloading (FE-49=02000), it will directly jump to 7% of the rated frequency of the motor to continue running. During unloading protection, if the load is restored, the drive will automatically restore to the set frequency operation.

FE-70	Overspeed detection value	Factory value	20.0%	Attribute	○
	Setting range	0.0% ~ 50.0% (maximum frequency)			
FE-71	Overspeed detection time	Factory value	1.0s	Attribute	○
	Setting range	0.0s ~ 60.0s			

This function is only effective when the drive has flux vector control. When the drive detects that the actual speed of the motor exceeds the maximum frequency, and the excess value is greater than the overspeed detection value FE-70, for a duration longer than the overspeed detection time FE-71, the drive reports the fault E.OS and handles it according to the fault protection action mode.

When the overspeed detection time is 0.0s, the overspeed fault detection is disabled.

FE-72	Detection value of excessive speed deviation	Factory value	20.0%	Attribute	○
	Setting range	0.0% ~ 50.0% (maximum frequency)			
FE-73	Detection time of excessive speed deviation	Factory value	5.0s	Attribute	○
	Setting range	0.0s ~ 60.0s			

This function is only effective when the drive has flux vector control. When the drive detects that the actual speed of the motor deviates from the set frequency, and the deviation value is greater than the detection value FE-72 of excessive speed deviation for a duration longer than the detection time FE-73 of excessive speed deviation, the drive reports the fault E.DEV and handles it according to the fault protection action mode.

When the detection time of excessive speed deviation is 0.0s, the fault detection of excessive speed deviation is cancelled.

FE-74	Software input open-phase sensitivity	Factory value	5%	Attribute	○
	Setting range	1% ~ 50%			
FE-75	Software input open-phase filtering	Factory value	20	Attribute	○
	Setting range	1 ~ 50			

When FE-12 input open-phase detection enables software input open-phase detection, the sensitivity of software input open-phase detection can be adjusted by modifying this parameter.

Input open-phase sensitivity:

The percentage setting of sensitivity is based on the rated bus voltage of the drive. Only when the fluctuation of bus voltage is greater than this set value will the software input open-phase fault be reported. Example: If the rated bus voltage is 540V, the 5% fluctuating voltage is 27 V.

Input open-phase filtering:

The filter parameters are used to eliminate the interference of software detection. The larger the parameter setting, the better the anti-interference performance, but the worse the sensitivity of software input open-phase detection; The smaller the parameter setting, the worse the anti-interference performance, but the higher the sensitivity of software input open-phase detection. Please set this parameter according to actual needs.

12.15 FF group user-defined function code

FF-00 ~ FF-29	User function code	Factory value		Attribute	○
	Setting range	F0-00~FE-xx A0-00~A5-xx U0-00~U0-xx			

This group of function codes is a user-defined parameter set. Users can select the required parameters from all function codes and summarize them into FF group as user-defined parameters. When switching to the user-defined parameter display mode through the QUICK key, you can quickly check the parameters set by the user.

FF group can provide up to 30 user-defined parameters, and the display value of FF group parameters is F0.00, which means that the user function code is empty. When entering the user-defined parameter mode, the displayed function codes are defined by FF-00 ~ FF-31, with the same sequence as the FE group function codes; if it is F0-00, skip.

12.16 A0 group terminal expansion function

A0-00	Minimum input of AI curve 4	Factory value	0.00V	Attribute	○
	Setting range	-10.00V ~ A0-02			
A0-01	Minimum input corresponding setting of AI curve 4	Factory value	0.0%	Attribute	○
	Setting range	-100.0% ~ 100.0%			
A0-02	AI curve 4 inflection point 1 input	Factory value	0.00V	Attribute	○
	Setting range	A0-00~ A0-04			
A0-03	Input corresponding setting for AI curve 4 inflection point 1	Factory value	30.0%	Attribute	○
	Setting range	-100.0% ~ 100.0%			
A0-04	AI curve 4 inflection point 2 input	Factory value	0.00V	Attribute	○
	Setting range	A0-02~ A0-06			
A0-05	Input corresponding setting for AI curve 4 inflection point 2	Factory value	60.0%	Attribute	○
	Setting range	-100.0% ~ 100.0%			
A0-06	Maximum input of AI curve 4	Factory value	10.00V	Attribute	○
	Setting range	A0-04 ~ 10.00V			
A0-07	Maximum input corresponding setting of AI curve 4	Factory value	100.0%	Attribute	○
	Setting range	-100.0% ~ 100.0%			

AI curve 4 can flexibly set a given setting corresponding to multipoint input voltage, as shown in the following figure:

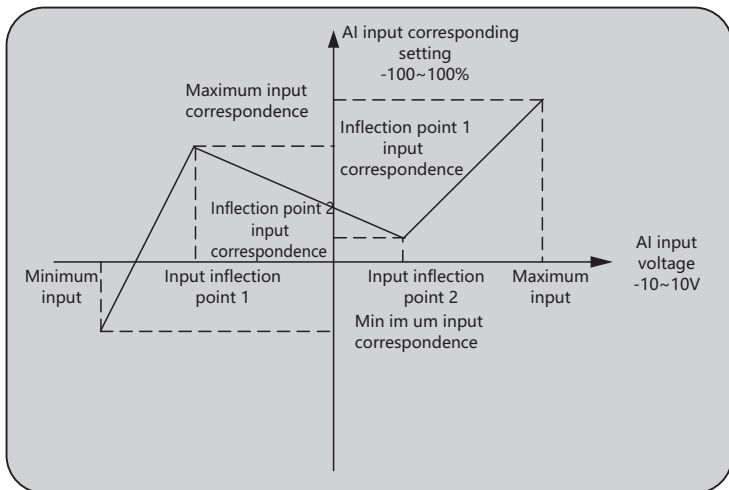

Please refer to AI4 for curve setting of AI5.

A0-24	AI1 set jump point	Factory value	0.0%	Attribute	○
	Setting range	-100.0% ~ 100.0%			
A0-25	AI1 set jump amplitude	Factory value	0.1%	Attribute	○
	Setting range	0.0% ~ 100.0%			
A0-26	AI2 set jump point	Factory value	0.0%	Attribute	○
	Setting range	-100.0% ~ 100.0%			
A0-27	AI2 set jump amplitude	Factory value	0.1%	Attribute	○
	Setting range	0.0% ~ 100.0%			
A0-28	AI3 set jump point	Factory value	0.0%	Attribute	○
	Setting range	-100.0% ~ 100.0%			
A0-29	AI3 set jump amplitude	Factory value	0.1%	Attribute	○
	Setting range	0.0% ~ 100.0%			

Analog inputs AI1~AI3, all with the setting value jump function. The jump function refers to fixing the analog corresponding set value as the value of jump point when the analog corresponding set value changes within the interval of jump point.

Example: The voltage of analog input AI fluctuates around 5.00V, ranging from 4.90 V to 5.10 V, with the minimum input of 0.00V corresponding to 0.0% and the maximum input of 10.00V corresponding to 100.0% for AI1, so the detected AI1 corresponding setting fluctuates between 49.0% and 51.0%.

If the jump point A0-24 of AI1 is set to 50.0% and the jump amplitude A0-25 of AI1 is set to 1.0%, the corresponding setting of AI1 input is fixed as 50.0% after the jump function processing, and AI1 is transformed into a stable input.

A0-30	Virtual VDI1 terminal function	Factory value	0	Attribute	●
	Setting range	0 ~ 59			
A0-31	Virtual VDI2 terminal function	Factory value	0	Attribute	●
	Setting range	0 ~ 59			
A0-32	Virtual VDI3 terminal function	Factory value	0	Attribute	●
	Setting range	0 ~ 59			
A0-33	Virtual VDI4 terminal function	Factory value	0	Attribute	●
	Setting range	0 ~ 59			
A0-34	Virtual VDI5 terminal function	Factory value	0	Attribute	●
	Setting range	0 ~ 59			

Virtual VDI1~VDI5 are exactly the same as DI on the control panel in function, and can be used as multi-function digital input. Please refer to the digital multi-function input DI function for details.

A0-35	Setting range	VDI valid state setting	Factory value	0	Attribute	●
		Units	VDI1			
		0	Whether VDI is valid or not is determined by the state of virtual VDOx			
		1	Whether VDI is valid or not is set by parameter A0-36			
		Tens	VDI2			
		Hundreds	VDI3			
		Thousands	VDI4			
A0-36	Setting range	VDI terminal state setting	Factory value	0	Attribute	○
		Units	VDI1			
		0	Invalid			
		1	Valid			
		Tens	VDI2			
		Hundreds	VDI3			
		Thousands	VDI4			
Ten thousands	VDI5					

The state of virtual VDI can be set in two ways, which can be selected through A0-35.

The VDI state is determined by the state of the corresponding virtual VDO:

The VDIx state is bound to the VDOx state. When VDOx acts, the corresponding VDIx is valid; When VDOx does not act, the corresponding VDIx is invalid.

For example, to set the output current of the drive as 120% of the rated current of the motor, the drive will stop and report the fault, and set as follows

F8-38 = 120%; F8-39 = 5%; Any reached current and detection amplitude.

A0-30 = 44 user-defined fault 1.

A0-41 = 28 virtual VDO1 output function selection <current reached 1>.

In this case, run the drive, and when the output current reaches any current reached detection condition, the drive will stop and report E.US1 user fault 1.

Set VDI state by parameter A0-36:

Parameters can be modified manually or by communication to change the state of VDI terminal.

For example, when A0-30 = 1 for forward running, and A0-31 = 2 for reverse running. At this time, A0-36 units and tens of data can be modified manually or by communication to control the forward and reverse running of the drive.

A0-37	Function selection when AI1 is used as DI	Factory value	0	Attribute	⊙
	Setting range	0 ~ 63			
A0-38	Function selection when AI2 is used as DI	Factory value	0	Attribute	⊙
	Setting range	0 ~ 63			
A0-39	Function selection when AI3 is used as DI	Factory value	0	Attribute	⊙
	Setting range	0 ~ 59			
A0-40	Effective mode selection when AI is used as DI	Factory value	0	Attribute	⊙
	Setting range	Units	AI1		
		0	High level valid		
		1	Low level valid		
		Tens	AI2		
Hundreds	AI3				

This group of function codes is used to use AI as DI. When AI is used as DI, the AI terminal state is high level when the AI input voltage is greater than 7V, and low level when the AI input voltage is less than 3V. Keep the state unchanged between 3V and 7V.

A0-40 is used to determine whether the high level of AI is valid or the low level is valid when AI is used as DI.

A0-41	VDO1 output function selection	Factory value	0	Attribute	○
	Setting range	0	Short circuit with physical DIx inside		
		1 ~ 41	Same as DO output function		
A0-46	VDO1 output delay time	Factory value	0.0s	Attribute	○
	Setting range	0.0s ~ 3600.0s			
A0-51	VDO output valid state	Factory value	0	Attribute	⊙
	Setting range	Units	VDO1		
		0	Positive logic		
		1	Negative logic		
		Tens	VDO2		
		Hundreds	VDO3		
		Thousands	VDO4		
Ten thousands	VDO5				

This group of parameters is used to set the function of the virtual VDO output.

There are two ways to select the function of VDOx:

Short circuit with physical DIx inside:

The state at this time is determined by the external terminal DIx of the drive. When the DIx input is valid, VDOx output is in valid state; When DIx input is invalid, VDOx output is in invalid state.

Same as DO output function:

For VDO function, please refer to F6 multi-function digital output DO function.

At the same time, positive logic or negative logic can be selected for the output valid state of VDOx.

12.17 A5 group second motor parameters

The definition and usage of all parameters of A5 group function code corresponding motor 2 and A5 group are the same as those of the first motor. Please refer to the details of related parameters and functions of the first motor F2 and F3 groups.

A5-00	Motor type	Factory value	0	Attribute	⊙
	Setting range	0	Normal asynchronous motor		
1		Drive asynchronous motor			
A5-01	Rated power of motor	Factory value	Model determination	Attribute	⊙
	Setting range	0.1kW ~ 6553.5kW			
A5-02	Rated voltage of motor	Factory value	Model determination	Attribute	⊙
	Setting range	1V ~ 2000V			
A5-03	Rated current of motor	Factory value	Model determination	Attribute	⊙
	Setting range	0.01A ~ 655.35A (drive power ≤ 55kW) 0.1A ~ 6553.5A (drive power >55kW)			
A5-04	Rated frequency of motor	Factory value	Model determination	Attribute	⊙
	Setting range	0.01Hz~ maximum frequency			
A5-05	Rated speed of motor	Factory value	Model determination	Attribute	⊙
	Setting range	1rpm ~ 65535rpm			
A5-06	Stator resistance of asynchronous motor	Factory value	Tuning parameter	Attribute	⊙
	Setting range	0.001Ω ~ 65.535Ω (drive power ≤ 55kW) 0.0001Ω ~ 6.5535Ω (drive power >55kW)			
A5-07	Rotor resistance of asynchronous motor	Factory value	Tuning parameter	Attribute	⊙
	Setting range	0.001Ω ~ 65.535Ω (drive power ≤ 55kW) 0.0001Ω ~ 6.5535Ω (drive power >55kW)			
A5-08	Leakage inductance of asynchronous motor	Factory value	Tuning parameter	Attribute	⊙
	Setting range	0.01mH ~ 655.35mH (drive power ≤ 55kW) 0.001mH ~ 65.535mH (drive power >55kW)			
A5-09	Mutual inductance of asynchronous motor	Factory value	Tuning parameter	Attribute	⊙
	Setting range	0.001mH ~ 65.535mH (drive power ≤ 55kW) 0.01mH ~ 655.35mH (drive power >55kW)			
A5-10	No-load current of asynchronous motor	Factory value	Tuning parameter	Attribute	⊙
	Setting range	0.01A ~ A5-03 (drive power ≤ 55kW) 0.1A ~ A5-03 (drive power >55kW)			

A5-27	Number of encoder lines		Factory value	1024	Attribute	◉
	Setting range		1 ~ 65535			
A5-28	Encoder type		Factory value	0	Attribute	◉
	Setting range	0	ABZ incremental encoder			
2		Resolver				
A5-30	ABZ incremental encoder AB phase sequence		Factory value	0	Attribute	◉
	Setting range	0	Forward			
1		Reverse				
A5-34	Pole pairs of resolver		Factory value	1	Attribute	◉
	Setting range		1 ~ 65535			
A5-36	PG disconnection detection time		Factory value	0.0s	Attribute	◉
	Setting range		0.0s ~ 10.0s			
A5-37	Tuning selection		Factory value	0	Attribute	◉
	Setting range	0	No operation			
		1	Static part parameter tuning of asynchronous machine			
		2	Dynamic complete tuning of asynchronous machine			
3		Static complete tuning of asynchronous machine				
A5-38	Speed loop proportional gain 1		Factory value	30	Attribute	○
	Setting range		1 ~ 100			
A5-39	Speed loop integration time 1		Factory value	0.50s	Attribute	○
	Setting range		0.01s ~ 10.00s			
A5-40	Switching frequency 1		Factory value	5.00Hz	Attribute	○
	Setting range		0.00 ~ A5-43			
A5-41	Speed loop proportional gain 2		Factory value	20	Attribute	○
	Setting range		1 ~ 100			
A5-42	Speed loop integration time 2		Factory value	1.00s	Attribute	○
	Setting range		0.01s ~ 10.00s			
A5-43	Switching frequency 2		Factory value	10.00Hz	Attribute	○
	Setting range		A5-40 ~ maximum frequency			
A5-44	Vector control slip gain		Factory value	100%	Attribute	○
	Setting range		50% ~ 200%			
A5-45	SVC speed feedback filtering time		Factory value	0.050s	Attribute	○
	Setting range		0.000s ~ 1.000s			

A5-47	Upper limit source of torque in speed control		Factory value	0	Attribute	○
	Setting range	0	A5-48 setting			
		1	A11			
		2	A12			
		3	A13			
		4	HDI			
		5	Communication setting			
		6	MIN(A11,A12)			
7	MAX(A11,A12)					
A5-48	Digital setting of upper limit of torque		Factory value	150.0%	Attribute	○
	Setting range		0.0% ~ 200.0%			
A5-49	Upper limit source of torque in speed control mode (power generation)		Factory value	0	Attribute	⊙
	Setting range	0	A5-47 setting (no distinction between motoring and power generation)			
		1	A11			
		2	A12			
		3	A13			
		4	HDI			
		5	Communication setting			
		6	MIN(A11, A12)			
		7	MAX(A11, A12)			
8	Parameter A5-50 setting					
A5-50	Digital setting of upper limit of torque (power generation)		Factory value	150.0%	Attribute	○
	Setting range		0.0% ~ 200.0%			
A5-51	Excitation regulation proportional gain		Factory value	2000	Attribute	○
	Setting range		0 ~ 60000			
A5-52	Excitation regulation integral gain		Factory value	1300	Attribute	○
	Setting range		0 ~ 60000			
A5-53	Torque regulation proportional gain		Factory value	2000	Attribute	○
	Setting range		0 ~ 60000			
A5-54	Torque regulation integral gain		Factory value	1300	Attribute	○
	Setting range		0 ~ 60000			
A5-60	Power generation limit enabled		Factory value	0	Attribute	⊙
	Setting range	0	Invalid			
		1	Effective			
A5-61	Upper limit of power generation		Factory value	Model determination	Attribute	○
	Setting range		0.0% ~ 200.0%			

A5-62	Control mode		Factory value	2	Attribute	⊙
	Setting range	0	Sensorless vector control (SVC)			
		1	Flux Vector Control (FVC)			
		2	V/F control			
A5-63	Selection of acceleration and deceleration time of motor 2		Factory value	0	Attribute	○
	Setting range	0	Same as the first motor			
		1	Acceleration and deceleration time 1			
		2	Acceleration and deceleration time 2			
		3	Acceleration and deceleration time 3			
		4	Acceleration and deceleration time 4			
A5-64	Motor 2 torque boost		Factory value	Model determination	Attribute	○
	Setting range		0.0%: automatic torque boost 0.1% ~ 30.0%			
A5-66	Oscillation suppression gain of motor 2		Factory value	Model determination	Attribute	○
	Setting range		0 ~ 100			

12.18 U0 group monitoring parameter

U0 parameter group is used to monitor the operation state information of drive, which can be viewed by customers through the panel to facilitate on-site debugging. This group of parameters is read-only and cannot be modified.

Parameter number	Function	Parameter range	Notes
U0-00	Operating frequency	0.00 ~ 500.00Hz	Display the current operating frequency of the drive
U0-01	Set frequency	0.00 ~ 500.00Hz	Display the target frequency of the drive
U0-02	Bus voltage	0.0V ~ 3000.0V	Display the voltage value of the drive bus
U0-03	Output voltage	0V ~ 1140V	Display the output voltage value of the drive during running
U0-04	Output current	0.00A ~ 655.35A (drive power ≤ 55kW) 0.0A ~ 6553.5A (drive power >55kW)	Display the output current value of the drive during running
U0-05	Output power	0.0KW ~ 6553.5KW	Display the output power (active power) of the drive during running
U0-06	Output torque	-200.0% ~ 200.0%	Display the percentage output value of motor rated torque
U0-07	X input state	0 ~ 32767	Display DI state, and convert it into binary correspondence (1 for high level, 0 for low level) Bit0 – X1; Bit1 – X2; Bit2 – X3; Bit3 – X4; Bit4 – HDI;
U0-08	DO output state	0 ~ 32767	Display DO state, and convert it into binary correspondence (1 for high level, 0 for low level) Bit0 – HDO; Bit1 – Relay1; Bit2 – Reserved; Bit3 – Relay2; Bit4 – Reserved;

Parameter number	Function	Parameter range	Notes
U0-09	AI1 voltage	0.00V ~ 11.00V	Corrected voltage
U0-10	AI2 voltage	0.00V ~ 11.00V	Corrected voltage
U0-11	AI3 voltage	0.00V ~ 11.00V	Corrected voltage
U0-12	Count value	0 ~ 65535	Display the pulse signal count value when X is set to <<counter input> function
U0-13	Length value	0 ~ 65535m	Display the record length value when X is set to <-length count input> function
U0-14	Load speed	0 ~ 65535	When stop: set frequency * coefficient (F7-07); When running: operating frequency * coefficient (F7-07)
U0-15	PID setting	0 ~ 65535	Set value (percentage) * Range (F9-04)
U0-16	PID feedback	0 ~ 65535	Feedback value (percentage) * Range (F9-04)
U0-17	PLC stage	0 ~ 15	Current stage of PLC function operation
U0-18	Input frequency of pulse	0.00kHz~100.00kHz	Display the high-speed pulse frequency input by HDI terminal
U0-19	Feedback speed	-320.00~320.00Hz	Actual operating frequency of the motor, VF is the output frequency of the drive, and the decimal point is set by F7-08
U0-20	Remaining running time	0.0 ~ 6500.0min	When the timing function is turned on (F8-42), the remaining running time of the drive is displayed
U0-21	AI1 voltage before correction	0.00V ~ 11.0V	Voltage before correction
U0-22	AI2 voltage before correction	0.00V ~ 11.0V	Voltage before correction
U0-23	AI3 voltage before correction	0.00V ~ 11.0V	Voltage before correction
U0-24	Motor speed	0 ~ 65535m/min	Display the linear speed of HDI sampling, and calculate the linear speed value according to the actual number of pulses sampled per minute and F9-36 (number of pulses per meter)
U0-25	Current power-on time	0 ~ 65535min	Power-off clearing
U0-26	Current running time	0 ~ 65535min	Stop clearing
U0-27	Input frequency of pulse	0 ~ 65535Hz	Same as U0-18, in Hz
U0-28	Communication set value	-100.00%~100.00%	Set frequency, set torque, etc. in communication setting
U0-29	Encoder feedback speed	-320.00Hz~320.00Hz	Motor operating frequency measured by the encoder, to display decimal point set by F7-08
U0-30	Main frequency display	0.00 ~ 500.00Hz	Display the main frequency setting
U0-31	Auxiliary frequency display	0.00 ~ 500.00Hz	Auxiliary frequency display
U0-32	Reserved		
U0-33	Reserved		
U0-34	Motor temperature value	0°C~200°C	When AI3 is connected to the motor temperature sensor, display the motor temperature
U0-35	Target torque	-200.0%~200.0%	Display the current torque target set value

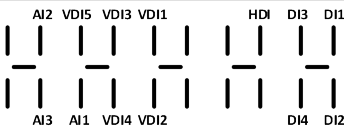
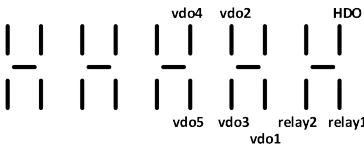
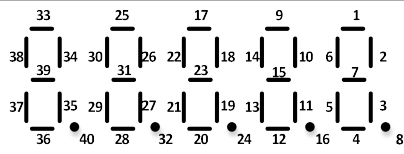
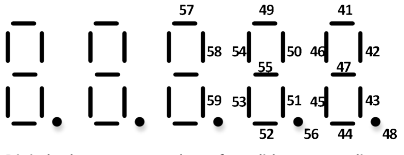
Parameter number	Function	Parameter range	Notes
U0-36	Resolver position	0 ~ 4096	Display the current position signal of resolver
U0-37	Power factor angle	-180°~180°	Display the power factor angle of the output power
U0-38	ABZ position	0 ~ 65535	Display the AB phase pulse count of the current ABZ or UVW encoder, which is the number of pulses after 4 times frequency multiplication. This value automatically increases when the encoder runs forward, and decreases when the encoder runs reverse. It restarts counting from 0 when it increases to 65535, or from 65535 when it decreases to 0
U0-39	V/F separation target voltage	0V~Rated voltage of motor	Display the target output voltage when running in VF separation state
U0-40	V/F separation output voltage	0V~Rated voltage of motor	Display the current actual output voltage when running in VF separation state
U0-41	Visual display of X input state		 <p>Digital tube segment code on for high level and off for low level</p>
U0-42	Visual display of DO output state		 <p>Digital tube segment code on for high level and off for low level</p>
U0-43	Visual display 1 of X function state		 <p>Digital tube segment code on for valid corresponding function, and off for invalid corresponding function</p>
U0-44	Visual display 2 of X function state		 <p>Digital tube segment code on for valid corresponding function, and off for invalid corresponding function</p>

Parameter number	Function	Parameter range	Notes
U0-45~U0-57	Reserved		
U0-58	Z signal counter	0 ~ 65535	Display the Z-phase pulse count of the current ABZ or UVW encoder. Every time the encoder runs forward or reverse, this value will increase or decrease by 1, and view this value to check whether the encoder is installed properly
U0-59	Reserved		
U0-60	Reserved		
U0-61	Drive state	0 ~ 65535	Display the operating state information of the drive and convert it into a binary correspondence table Bit 1: Bit0 – 0: Stop, 1: Forward; 2: Reverse Bit 3: Bit2 – 0: Constant speed, 1: Acceleration; 2: Deceleration Bit4 – 0: Bus voltage is normal; 1: Undervoltage
U0-62	Current fault coding	0 ~ 99	Display the current fault code. Please see the fault table for details
U0-63	Reserved		
U0-64	Reserved		
U0-65	Upper limit of torque	-200.0%~200.0%	Percent shows the currently set upper limit of torque
U0-66~U0-72	Reserved		
U0-73	Motor selection	0 ~ 1	0: Motor 1 1: Motor 2
U0-74	Reserved		
U0-75	Inversion module	-20°C ~ 150°C	Radiator temperature
U0-76	Product No.	600	Drive model serial number
U0-77	Cumulative running time	0 ~ 65535 kW-h	
U0-78	Performance version number		
U0-79	Functional version number		
U0-80	Cumulative power-on time	0~65535 hours	
U0-81	Cumulative electricity consumption	0~65535 kW-h	
U0-82	Low cumulative electricity consumption	0~65535 kW-h	
U0-83	High cumulative electricity consumption	0~65535 kW-h	
U0-84	Drive rating capacity	0.0KW~6553.5KW	
U0-85	Rated current of drive	0.00A~ 655.35A (drive power≤55kW) 0.0A~ 6553.5A (drive power>55kW)	

12.19 MODBUS communication

1) Networking mode

The drive provides RS485 communication interface and adopts international standard Modbus communication protocol for master-slave communication. Users can realize centralized control through PC/PLC, upper computer monitoring software, etc. (setting the control command and operating frequency of the drive, modifying the parameters of relevant function codes, monitoring the working state and fault information of the drive, etc.) to meet specific application requirements.

There are two networking modes of the drive (as a slave station): single master/multi-slave mode and single master/single slave mode, as shown in the following figure:

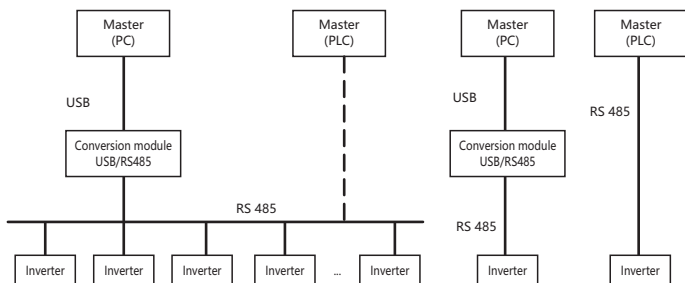

Modbus communication related parameters can be described with reference to Fb group function code, and the default communication parameters are as follows:

Address of slave station:0x01

Baud rate:9600bps

Data format:8-N-2 (8 data bits, no parity bit, 2 stop bits)

2) Wiring instructions

2.1) Topological structure

No repeater RS-485-Modbus is configured, and there is a trunk cable directly connected to all equipment or connected through short branch cables.

Trunk cable, also known as bus, can be very long. Its two ends must be connected to line terminals. Repeaters can be also used between multiple RS-485 Modbus. And the address of each slave address in the network is unique, which is the basis of ensuring Modbus serial communication.

2.2) Length

The end-to-end length of trunk cables must be limited. The maximum length is related to baud rate, cable (specification, capacitance or characteristic impedance), number of loads on chain and network configuration (2-wire or 4-wire system).

For cables with high-speed baud rate of 9600bps and AWG26 (or thicker), the maximum length is 1000m.

The branch must be short and cannot exceed 20m. If a multipoint splitter with n branches is used, the maximum length of each branch must be limited to 40m divided by n.

2.3) Grounding form

The "common terminal" circuit (the common terminal of signal and optional power supply) must be directly connected to the protective ground, and it is better to ground the whole bus at a single point. Usually, this point can be selected on the master station or its splitter.

2.4) Cable

Modbus cable on serial link must be shielded. At one end of each cable, its shield must be connected to the protective ground. If a connector is used at this end, connect the connector housing to the cable shielding. RS485-Modbus must adopt a balanced pair and a third wire (for the common terminal).

For RS485-Modbus, the cable diameter must be wide enough to allow the maximum length (1000m).

AWG24 can meet the needs of Modbus data transmission.

3) Communication mode

- 1) The communication protocol of the drive is Modbus protocol, which supports RTU protocol.
- 2) The drive is a slave, and the master-slave point-to-point communication. When the master sends a command using the broadcast address, the slave does not answer.
- 3) In the case of multi-machine communication or long-distance communication, connecting (100~120) ohm resistors in parallel at the positive terminal and negative terminal of the signal line of the master station communication can improve the immunity of communication.
- 4) The drive provides an RS485 interface. If the communication port of the external device is RS232, an additional RS232/RS485 conversion device is required.
- 5) Protocol format

Modbus protocol supports RTU mode, and the corresponding frame format is shown in the following figure

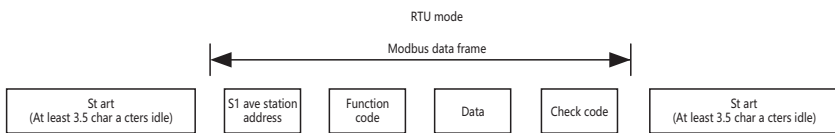

In RTU mode, the idle time between frames is the greater of the function code setting and Modbus internal agreed value. The minimum inter-frame idle agreed in Modbus is as follows: The frame header and the frame footer are defined by the bus idle time of no less than 3.5 bytes. There shall be at least 3.5 characters of bus idle between frames, and it is not required to accumulate the start and end idle for the bus idle between frames.

Address of slave station: Setting range of drive slave station address 1 ~ 247. When the address sent by the master station is 0, it is a broadcast address, and the slave station does not need to be recovered. Broadcast commands can only be used for write commands.

Function code: At present, there are three Modbus function codes supported by the drive

Function code	Notes
0x03	Read register instruction
0x06	Write single register instruction
0x10	Write multiple register instructions

Data: The Modbus register is 2 bytes long, so the data written into the register by the drive is usually 2 bytes, and the data read from the drive is also 2 bytes. The drive can read or write up to 12 register data at a time.

Check code: CRC-16 is used for data check, with the whole frame information adopted for check, and the low byte check data sent before the high byte.

Communication example:

Communication 0x03 function code reads F0-08 data

Master station → Drive		Master station ← Drive	
Slave station address	0x01	Slave station address	0x01
Function code	0x03	Function code	0x03
Register high byte	0x00	Number of registers	0x02
Register low byte	0x08	Data high byte	0x13
Number of registers high byte	0x00	Data low byte	0x88
Number of registers low byte	0x01	CRC low byte	0xB5
CRC low byte	0x05	CRC high byte	0x12
CRC high byte	0xC8		

Communication 0x06 function code changes F0-08 parameter to 40.00Hz

Master station → Drive		Master station ← Drive	
Slave station address	0x01	Slave station address	0x01
Function code	0x06	Function code	0x06
Register high byte	0x00	Register high byte	0x00
Register low byte	0x08	Register low byte	0x08
Data high byte	0x0F	Data high byte	0x0F
Data low byte	0xA0	Data low byte	0xA0
CRC low byte	0x0D	CRC low byte	0x0D
CRC high byte	0x80	CRC high byte	0x80

Communication 0x10 function code changes F0-17 and F0-18 parameters to 10.0s

Master station → Drive		Master station ← Drive	
Slave station address	0x01	Slave station address	0x01
Function code	0x10	Function code	0x10
Start register high byte	0x00	Start register high byte	0x00
Start register low byte	0x11	Start register low byte	0x11
Number of registers high byte	0x00	Number of registers high byte	0x00
Number of registers low byte	0x02	Number of registers low byte	0x02
Number of register bytes	0x04	CRC low byte	0x11
Data 1 high byte	0x00	CRC high byte	0xCD
Data 1 low byte	0x64		
Data 2 high byte	0x00		
Data 2 low byte	0x64		
CRC low byte	0x73		
CRC high byte	0x5B		

Data returned by communication fault frame:

Fault frame (master station ← drive)	
Slave station address	
0x80 + Function code	
Fault codes (defined in the following table)	
CRC low byte	
CRC high byte	

Definition of communication fault code:

Ser.No.	Communication fault code	Fault description
1	0x01	Illegal command
2	0x02	Illegal address
3	0x03	Illegal data
4	0x04	Other errors (CRC error, parameter read-only, parameter locking, etc.)

a) Function code parameter address rule

Address representation rules with function code group number and label as parameters:

High byte: 0x00~0x0F (F0~FF group), 0x40~0x45 (A0~A5 group) and 0x70 (U0 group)

Low byte: 0x00~0xFF

For example, to access the function code F0-08, the access address of the function code is expressed as 0x0008;

Note:

U group: read-only and non-modifiable.

Some parameters cannot be changed when the drive is in operation; Some parameters cannot be changed regardless of the state of the drive; When changing the parameters of the function code, attention shall be also paid to the range, unit and related description of the parameters.

Function code group number	Communication access address	Communication modifies the function code address in RAM
F0~ FF group	0x0000 ~ 0x0FFF	0x8000 ~ 0x8FFF
A0~ A5 group	0x4000 ~ 0x45FF	0xC000 ~ 0xC5FF
U0 group	0x7000 ~ 0x70FF	

As EEPROM is frequently stored, it will reduce the service life of EEPROM, therefore, some function codes do not need to be stored in communication mode, just change their values in RAM. When data only needs to be saved in RAM (that is, data is not saved after power-off), the highest address position is set to "1".

Example:

The function code F0-08 is not stored in EEPROM, and the address is expressed as 8008;

This address means that you can only write RAM, but not read. When reading, it is an invalid address.

Communication settings: (write only)

Communication setting address	Set value	Parameter description
3201H	-10000 ~ 10000	10000 for 100.00%, -10000 for -100.00%

The communication set value is a percentage of the relative value, with 10000 for 100.00% and -10000 for -100.00%. For data of frequency dimension, this percentage is the percentage of the relative maximum frequency (F0-10); For torque dimension data, the percentage is F3-11.

Note: The "communication setting" options in the parameters all set data through this address.

Control command: (write only)

Command	Address	Command function
Control command	3200H	0000: No command
		0001: Forward running
		0002: Reverse running
		0003: Stop by deceleration
		0004: Forward jog
		0005: Reverse jog
		0006: Reserved
		0007: Free stop
		0008: Fault reset
Digital output control	3202H	BIT0: DO1 output control
		BIT1: DO2 output control
		BIT2: RELAY1 output control
		BIT3: RELAY2 output control
		BIT4: HDO output control
		BIT5: VDO1
		BIT6: VDO2
		BIT7: VDO3
		BIT8: VDO4
BIT9: VDO5		
AO1 control	3203H	0 ~ 7FFF means 0%~ 100%
AO2 control	3204H	0 ~ 7FFF means 0%~ 100%
Pulse control	3205H	0 ~ 7FFF means 0%~ 100%

Read drive state: (read-only)

State address	State word
3300H	Bit0: Run/Stop (0: Stop; 1: Running)
	Bit1: Forward/Reverse (0: Forward; 1: Reverse)
	Bit2: Running at zero speed (1 for valid)
	Bit3: Running at acceleration (1 for valid)
	Bit4: Running at deceleration (1 for valid)
	Bit5: Running at constant speed (1 for valid)
	Bit6: Reserved
	Bit7: Reserved
	Bit8: Reserved
	Bit9: Reserved
	Bit10: Reserved
	Bit11: Reserved
	Bit12: Drive fault (1 for fault)
	Bit13: Ready for operation (1 for ready)
	Bit14: Reserved
Bit15: Reserved	

Stop/Running parameters section:

Parameter address	Parameter description	Parameter address	Parameter description
3400H	Output frequency	3411H	PLC step
3401H	Set frequency	3412H	Count value input
3402H	Bus voltage	3413H	Length value input
3403H	Output voltage	3414H	Feedback speed, in 0.1Hz
3404H	Output current	3415H	Linear speed
3405H	Running speed	3416H	AI1 voltage before correction
3406H	Output power	3417H	AI2 voltage before correction
3407H	Output torque	3418H	AI3 voltage before correction
3408H	PID settings	3419H	Remaining running time
3409H	PID feedback	341AH	Current power-on time
340AH	X input flag	341BH	Current running time
340BH	DO output flag	341CH	PULSE input frequency, in 1Hz
340CH	Target torque (%)	341DH	Loading speed
340DH	AI1 voltage	341EH	Actual feedback speed
340EH	AI2 voltage	341FH	Main frequency X display
340FH	AI3 voltage	3420H	Auxiliary frequency Y display
3410H	PULSE input frequency, in 0.01kHz		

F0-28 parameter initialized communication:

In order to prevent mis-operation, it is necessary to communicate on the user password F7-00 before modifying F0-28, and write data into F7-00 before operating F0-28. Even if the user password is not set, be sure to write 0 to F7-00. For example, a parameter needs to be reset

Send data:01 06 07 00 00 00 88 BE

Return data:01 06 07 00 88 88 EE D8

Re-write

Send data:01 06 00 1C 00 02 C9 CD

Return data:01 06 00 1C 00 02 C9 CD

User-defined parameter group FF group communication:

1. When communication needs to modify the parameter address mapped by the user-defined parameter group FF.XX, and the register address of the operation is 0x2FXX, for example, if is required to modify the parameter F0.08 mapped by FF.00, the following instruction is sent:

Send data:01 06 2F 00 F0 08 C4 D8

Return data:01 06 2F 00 F0 08 C4 D8

Different parameter groups map different data, as shown in the following table:

Parameter set	Mapping communication data
F0~FE group	0xF0XX
A0 group	0xA0XX
U group	0x70XX

2. When the register address of communication operation is FF.XX, the parameters mapped in FF group are used for communication operation. For example, F0.08 is set in FF.00, and F0.08 parameter is modified when the 0F.00 address is written by 06 function code

Send data: 01 06 0F 00 03 E8 8A 60

Return data: 01 06 0F 00 03 E8 8A 60

At this time, F0.08 preset frequency is modified by 10.00Hz.

13 Parameter Summary

°○: It indicates that the set value of this parameter can be changed when the drive is in stop or running state;

°⊙: It indicates that the set value of this parameter cannot be changed when the VFD is running;

°●: It indicates that the value of this parameter is the actual testing record value and cannot be changed;

Parameters	Name	Setting range	Factory value	Change
F0 group Basic functions				
F0-00	TP type setting	1: T type (constant torque load model) 2: P type (fan, water pump load type)	1	●
F0-01	The first motor control mode	0: sensorless vector control (SVC) 1: Flux Vector Control (FVC) 2: V/F control	2	●
F0-02	Run instruction selection	0: Operation panel 1: Terminal 2: Communication	0	○
F0-03	Main frequency instruction input selection	0: Digital setting (without power-off memory) 1: Digital setting (with power-off memory) 2: AI1 3: AI2 4: AI3 5: Pulse setting (HDI) 6: Multi-segment instruction 7: Simple PLC 8: PID 9: Communication setting	0	●
F0-04	Auxiliary frequency command input selection	Same as F0-03 (main frequency command input selection)	0	●
F0-05	Range selection of auxiliary frequency instruction during superposition	0: relative to the maximum frequency 1: Relative to main frequency instruction	0	○
F0-06	Range of auxiliary frequency instruction during superposition	0%~150%	100%	○

F0-07	Frequency instruction superposition selection	Units: Frequency instruction selection 0: Main frequency instruction 1: Main and auxiliary operation results (the operation relationship is determined by tens) 2: Switching between main frequency instruction and auxiliary frequency instruction 3: Switching between main frequency instruction and main and auxiliary operation results 4: Switching between auxiliary frequency instruction and main and auxiliary operation results Tens: Relationship between main and auxiliary operation of frequency source 0: Main + Auxiliary 1: Main - Auxiliary 2: Maximum of the two 3: Minimum of the two	00	○
F0-08	Preset frequency	0.00Hz ~ maximum frequency (F0-10)	50.00Hz	○
F0-09	Direction of operation	0: Run in the default direction 1: Run in the opposite direction to the default direction	0	○
F0-10	Maximum frequency	50.00Hz~500.00Hz	50.00Hz	●
F0-11	Upper limiting frequency instruction selection	0: F0-12 setting 1: AI1 2: AI2 3: AI3 4: Pulse setting 5: Communication setting	0	●
F0-12	Upper limiting frequency	Lower limiting frequency F0-14~ Maximum frequency F0-10	50.00Hz	○
F0-13	Upper limiting frequency offset	0.00Hz~ Maximum frequency F0-10	0.00Hz	○
F0-14	Lower limit frequency	0.00Hz~ Upper limiting frequency F0-12	0.00Hz	○
F0-15	Carrier frequency	Model determination	Model determination	○
F0-16	Carrier frequency is adjusted with temperature	0: No 1: Yes	1	○
F0-17	Acceleration time 1	0.00s~650.00s(F0-19=2) 0.0s~6500.0s(F0-19=1) 0s~65000s(F0-19=0)	Model determination	○
F0-18	Deceleration time 1	0.00s~650.00s(F0-19=2) 0.0s~6500.0s(F0-19=1) 0s~65000s(F0-19=0)	Model determination	○
F0-19	Acceleration and deceleration time unit	0: 1s 1: 0.1s 2: 0.01s	1	●
F0-20	Digital setting frequency stop memory selection	0: No memory 1: Memory	0	○
F0-21	Acceleration and deceleration time reference frequency	0: Maximum frequency (F0-10) 1: Set frequency 2: 100Hz	0	●

F0-22	Runtime frequency instruction UP/DOWN reference	0: Operating frequency 1: Set frequency	0	●
F0-23	Run instruction bundling main frequency instruction selection	Units: Operation panel command binding frequency source selection 0: No binding 1: Digital setting frequency 2: AI1 3: AI2 4: AI3 5: Pulse setting (HDI) 6: Multi-speed 7: Simple PLC 8: PID 9: Communication setting Tens: Terminal binding frequency source selection Hundreds: Communication binding frequency source selection	000	○
F0-24	Reserved			
F0-25	Reserved			
F0-26	Reserved			
F0-27	Selection of motor parameter group	0: Motor parameter group 1 1: Motor parameter group 2	0	●
F0-28	Parameter initialization	0: No operation 01: Clear record information 02: Restore factory parameters, excluding motor parameters 04: Back up user's current parameters 05: Restore user backup parameters	0	●

F1 group start-stop control

F1-00	Startup mode	0: direct startup 1: Speed tracking and restart 2: Pre-excitation start 3: SVC quick start	0	○
F1-01	Speed tracking mode	0: Starting from the stop frequency 1: Starting from the power frequency 2: Starting from the maximum frequency	0	●
F1-02	Speed tracking speed	1~100	20	●
F1-03	Starting frequency	0.00Hz~50.00Hz	0.00Hz	○
F1-04	Holding time of starting frequency	0.0s~100.0s	0.0s	●
F1-05	Starting DC braking current/pre-excitation current	0%~100%	50%	●
F1-06	Starting DC braking time/pre-excitation time	0.0s~100.0s	0.0s	●
F1-07	Acceleration and deceleration mode	0: linear acceleration and deceleration 1: Static S curve 2: Dynamic S curve	0	●
F1-08	Time proportion at the beginning of S curve	0.0%~(100.0%-F1-09)	30.0%	●

F1-09	Time proportion at the end of S curve	0.0%~(100.0%-F1-08)	30.0%	●
F1-10	Stop mode	0: Stop by deceleration 1: Free stop	0	○
F1-11	Starting frequency of stop DC braking	0.00Hz ~ maximum frequency	0.00Hz	○
F1-12	Waiting time for stop DC braking	0.0s~100.0s	0.0s	○
F1-13	Stop DC braking current	0%~100%	50%	○
F1-14	Stop DC braking time	0.0s~100.0s	0.0s	○
F1-15	Brake utilization rate	0%~100%	100%	○
F1-16	Speed tracking closed-loop current KP	0 ~ 1000	Model determination	●
F1-17	Speed tracking closed-loop current KI	0 ~ 1000	Model determination	●
F1-18	Speed tracking current	30%~200%	Model determination	●
F1-19	Reserved			
F1-20	Reserved			
F1-21	Demagnetization time (SVC valid)	0.00~5.00s	Model determination	○

F2 group motor parameters

F2-00	Motor type selection	0: Normal asynchronous motor 1: Frequency conversion asynchronous motor	0	●
F2-01	Rated power of motor	0.1kW~1000.0kW	Model determination	●
F2-02	Rated voltage of motor	1V~2000V	Model determination	●
F2-03	Rated current of motor	0.01A~655.35A (drive power ≤ 55kW) 0.1A~6553.5A (drive power >55kW)	Model determination	●
F2-04	Rated frequency of motor	0.01Hz~maximum frequency	Model determination	●
F2-05	Rated speed of motor	1rpm~65535rpm	Model determination	●
F2-06	Stator resistance of asynchronous motor	0.001Ω~65.535Ω (drive power ≤55kW) 0.0001Ω~6.5535Ω (drive power >55kW)	Tuning parameter	●
F2-07	Rotor resistance of asynchronous motor	0.001Ω~65.535Ω (drive power ≤55kW) 0.0001Ω~6.5535Ω (drive power >55kW)	Tuning parameter	●
F2-08	Leakage inductance of asynchronous motor	0.01mH~655.35mH (drive power ≤55kW) 0.001mH~65.535mH (drive power >55kW)	Tuning parameter	●
F2-09	Mutual inductance of asynchronous motor	0.1mH~6553.5mH (drive power ≤ 55kW) 0.01mH~655.35mH (drive power >55kW)	Tuning parameter	●
F2-10	No-load current of asynchronous motor	0.01A~F2-03 (drive power ≤ 55kW) 0.1A~F2-03 (drive power >55kW)	Tuning parameter	●
F2-11 ~ F2-36	Reserved			
F2-37	Tuning selection	0: No operation 1: Static part parameter tuning of asynchronous machine	0	●

F2-37	Tuning selection	2: Dynamic complete tuning of asynchronous machine 3: Static complete tuning of asynchronous machine	0	•
-------	------------------	---	---	---

F3 group vector control parameters

F3-00	Speed/Torque control mode selection	0: Speed control 1: Torque control	0	•
F3-01	Speed loop proportional gain 1	1~100	30	○
F3-02	Speed loop integration time 1	0.01s~10.00s	0.50s	○
F3-03	Switching frequency 1	0.00~F3-06	5.00Hz	○
F3-04	Speed loop proportional gain 2	1~100	20	○
F3-05	Speed loop integration time 2	0.01s~10.00s	1.00s	○
F3-06	Switching frequency 2	F3-03 ~ maximum frequency	10.00Hz	○
F3-07	Vector control slip gain	50%~200%	100%	○
F3-08	SVC speed feedback filtering time	0.000s~0.100s	0.015s	○
F3-09	Reserved			
F3-10	Instruction selection of torque upper limit in speed control mode	0: Parameter F3-11 setting 1: AI1 2: AI2 3: AI3 4: HDI pulse 5: Communication setting 6: MIN(AI1, AI2) 7: MAX(AI1, AI2) The full scale of options 1-7 corresponds to F3-11	0	○
F3-11	Digital setting of torque upper limit in speed control mode	0.0%~200.0%	150.0%	○
F3-12	Instruction selection of torque upper limit in speed control mode (power generation)	0: Parameter F3-11 setting (no distinction between motoring and power generation) 1: AI1 2: AI2 3: AI3 4: HDI pulse 5: Communication setting 6: MIN(AI1,AI2) 7: MAX(AI1,AI2) 8: Parameter F3-13 setting The full scale of options 1-8 corresponds to F3-13	0	○
F3-13	Digital setting of upper limit of torque in speed control mode (power generation)	0.0% ~ 200.0%	150.0%	○
F3-14	Excitation regulation proportional gain	0~60000	2000	○
F3-15	Excitation regulation integral gain	0~60000	1300	○
F3-16	Torque regulation proportional gain	0~60000	2000	○
F3-17	Torque regulation integral gain	0~60000	1300	○
F3-18	Speed loop integral attribute	Units: Integral separation 0: invalid 1: valid	0	○

F3-19	Reserved			
F3-20	Reserved			
F3-21	Reserved			
F3-22	Reserved			
F3-23	Power generation limit enabled	0: invalid 1: Whole-process valid	0	○
F3-24	Upper limit of power generation	0.0~200.0%	Model determination	○
F3-25	Selection of torque setting in torque control mode	0: Digital setting (F3-27) 1:A11 2:A12 3:A13 4:HDI pulse 5: Communication setting 6:MIN(AI1, AI2) 7:MAX(AI1, AI2) (Full scale of options1-7 corresponds toF3-27digital setting)	0	●
F3-26	Reserved			
F3-27	Digital setting of torque in torque control mode	-200.0%~200.0%	150.0%	○
F3-28	Reserved			
F3-29	Maximum forward frequency of torque control	0.00Hz~ maximum frequency	50.00Hz	○
F3-30	Maximum reverse frequency of torque control	0.00Hz~ maximum frequency	50.00Hz	○
F3-31	Filtering time for torque rise	0.00s~650.00s	0.00s	○
F3-32	Filtering time for torque drop	0.00s~650.00s	0.00s	○
F3-33 ~ F3-42	Reserved			

F4 group V/F control parameters

F4-00	V/F curve setting	0: Linear V/F 1: multipoint V/F 2~9: Reserved 10: V/F complete separation mode 11: V/F semi-separation mode	0	●
F4-01	Torque boost	0.0%: (automatic torque boost) 0.1%~30.0%	Model determination	○
F4-02	Torque boost cutoff frequency	0.00Hz~maximum frequency	50.00Hz	●
F4-03	Multipoint V/F frequency point 1	0.00Hz~F4-05	0.00Hz	●
F4-04	Multipoint V/F voltage point 1	0.0%~100.0%	0.0%	●
F4-05	Multipoint V/F frequency point 2	F4-03~F4-07	0.00Hz	●
F4-06	Multipoint V/F voltage point 2	0.0%~100.0%	0.0%	●
F4-07	Multipoint V/F frequency point 3	F4-05 ~ Rated frequency of motor (F2-04)	0.00Hz	●
F4-08	Multipoint V/F voltage point 3	0.0%~100.0%	0.0%	●
F4-09	V/F slip compensation gain	(0.0~200.0)%	0.0%	○
F4-10	V/F over-excitation gain	0~200	64	○
F4-11	V/F oscillation suppression gain	0~100	40	○

F4-12	Reserved			
F4-13	Voltage source of V/F separation	0: Digital setting (F4-14) 1: AI1 2: AI2 3: AI3 4: Pulse setting (HDI) 5: Multi-segment instruction 6: Simple PLC 7: PID 8: Communication setting Note: 100.0% corresponds to the rated voltage of motor	0	○
F4-14	Voltage digital setting of V/F separation	0V~ Rated voltage of motor	0V	○
F4-15	Voltage acceleration time of V/F separation	0.0s~1000.0s Note: It is the time when 0V changes to the rated voltage of motor	0.0s	○
F4-16	Voltage deceleration time of V/F separation	0.0s~1000.0s Note: It indicates the time when the rated voltage of the motor changes to 0V	0.0s	○
F4-17	Selection of V/F separation stop mode	0: Frequency/voltage separately decreases to 0 1: Frequency decreases again after the voltage decreases to 0	0	○
F4-18	Overcurrent stall action current	50~200%	150%	●
F4-19	Overcurrent stall enabled	0: invalid 1: valid	1 (valid)	●
F4-20	Overcurrent stall suppression gain	0~100	20	○
F4-21	Current compensation of double-speed overcurrent stall action Coefficient	50~200%	50%	●
F4-22	Overvoltage stall action voltage	380V model: 650.0V~800.0V 220V model: 320.0V~800.0V	380V model: 760V 220V model: 380V	●
F4-23	Overvoltage stall enabled	0: invalid 1: valid	1 (valid)	●
F4-24	Overvoltage stall suppression frequency gain	0~100	30	○
F4-25	Overvoltage stall suppression voltage gain	0~100	30	○
F4-26	Maximum rise frequency limit of overvoltage stall	0~50Hz	5Hz	●
F4-27 F4-50	Reserved			

F5 group input terminal				
F5-00	X1 terminal function selection	0: No function	1	●
F5-01	X2 terminal function selection	1: Forward running FWD or run command	4	●
F5-02	X3 terminal function selection	2: Reverse running REV or forward and reverse running direction	9	●
F5-03	X4 terminal function selection		12	●
F5-04	HDI terminal function selection	(Note: When it is set to 1 or 2, it shall be used along with F5-11. For details, please refer to the parameters	13	●
F5-05	Reserved	Parameter description)	0	
F5-06	Reserved		0	
F5-07	Reserved	3: Three-wire running control	0	
F5-08	Reserved	4: Forward jog (FJOG)	0	
		5: Reverse jog (RJOG)		
		6: Terminal UP		
		7: Terminal DOWN		
		8: Free stop		
		9: Fault reset (RESET)		
		10: Running pause		
		11: External fault normally on input		
		12: Multi-segment instruction terminal 1		
		13: Multi-segment instruction terminal 2		
		14: Multi-segment instruction terminal 3		
		15: Multi-segment instruction terminal 4		
		16: Acceleration and deceleration time selection terminal 1		
		17: Acceleration and deceleration time selection terminal 2		
		18: Frequency command switching		
		19: UP/DOWN setting cleared (terminal, keyboard)		
F5-09	Reserved	20: Control command switch terminal 1	0	
		21: Acceleration and deceleration disabled		
		22: PID pause		
		23: Simple PLC state reset		
		24: Swing frequency pause		
		25: Counter input		
		26: Counter reset		
		27: Length count input		
		28: Length reset		
		29: Torque control disabled		
		30: Pulse frequency input (valid only for HDI)		
		31: Reserved		
		32: Immediate DC braking		
		33: External fault normally off input		
		34: Frequency modification enabled		
		35: PID action direction reversed		
		36: External stop terminal 1		
		37: Control command switch terminal 2		
		38: PID integration pause		
		39: Switch between main frequency and preset frequency		

		40: Auxiliary frequency and preset frequency switching 41: Motor terminal selection function 42: Reserved 43: PID parameter switching 44: User-defined fault 1 45: User-defined fault 2 46: Speed control/torque control switching 47: Emergency stop 48: External stop terminal 2 49: Deceleration DC braking 50: Current running time cleared 51: Two-wire/three-wire switching 52: Reverse frequency disabling 53-63: Reserved		
F5-10	X terminal filtering time	0.000s~1.000s	0.010s	○
F5-11	Terminal command mode	0: Two-wire 1 1: Two-wire 2 2: Three-wire 1 3: Three-wire 2	0	●
F5-12	Terminal UP/DOWN change rate	0.001Hz/s~65.535Hz/s	1.00Hz/s	○
F5-13	Minimum input of AI curve 1	0.00V~F5-15	0.00V	○
F5-14	Minimum input corresponding setting of AI curve 1	-100.0%~+100.0%	0.0%	○
F5-15	Maximum input of AI curve 1	F5-13~+10.00V	10.00V	○
F5-16	Maximum input corresponding setting of AI curve 1	-100.0%~150.0%	100.0%	○
F5-17	AI1 filtering time	0.00s~10.00s	0.10s	○
F5-18	Minimum input of AI curve 2	0.00V~F5-20	0.00V	○
F5-19	Minimum input corresponding setting of AI curve 2	-100.0%~+100.0%	0.0%	○
F5-20	Maximum input of AI curve 2	F5-18~+10.00V	10.00V	○
F5-21	Maximum input corresponding setting of AI curve 2	-100.0%~150.0%	100.0%	○
F5-22	AI2 filtering time	0.00s~10.00s	0.10s	○
F5-23	Minimum input of AI curve 3	-10.00V~F5-25	-10.00V	○
F5-24	Minimum input corresponding setting of AI curve 3	-100.0%~+100.0%	-100.0%	○
F5-25	Maximum input of AI curve 3	F5-23~+10.00V	10.00V	○
F5-26	Maximum input corresponding setting of AI curve 3	-100.0%~150.0%	100.0%	○
F5-27	AI3 filtering time	0.00s~10.00s	0.10s	○
F5-28	Minimum frequency of pulse input	0.00kHz~F5-30	0.00kHz	○
F5-29	Corresponding setting of minimum input frequency of pulse	-100.0%~100.0%	0.0%	○
F5-30	Maximum input frequency of pulse	F5-28~100.00kHz	50.00kHz	○
F5-31	Corresponding setting of maximum input frequency of pulse	-100.0%~100.0%	100.0%	○
F5-32	Pulse filtering time	0.00s~10.00s	0.10s	○

F5-33	AI curve selection	Units: AI1 curve selection 1: Curve 1 (2 points, see F5-13~F5-16) 2: Curve 2 (2 points, see F5-18~F5-21) 3: Curve 3 (2 points, see F5-23~F5-26) 4: Curve 4 (4 points, see A0-00~A0-07) 5: Curve 5 (4 points, see A0-08~A0-15) Tens: AI2 curve selection, same as above Hundreds: AI3 curve selection, same as above	321	○
F5-34	Selection of AI below the minimum input setting	Units: selection of AI1 below the minimum input setting 0: Corresponding minimum input setting 1: 0.0% Tens: selection of AI2 below the minimum input setting, same as above Hundreds: selection of AI3 below the minimum input setting, same as above	000	○
F5-35	X1 delay time	0.0s~3600.0s	0.0s	○
F5-36	X2 delay time	0.0s~3600.0s	0.0s	○
F5-37	X3 delay time	0.0s~3600.0s	0.0s	○
F5-38	X terminal effective mode selection 1	0: High level valid 1: Low level valid Units: X1 Tens: X2 Hundreds: X3 Thousands: X4 Ten thousands: HDI	00000	●
F5-39	Reserved			
F5-40	Reserved			
F5-41	AI1 measured voltage 1	-10.00V~10.000V	Factory correction	○
F5-42	AI1 displayed voltage 1	-10.00V~10.000V	Factory correction	○
F5-43	AI1 measured voltage 2	-10.00V~10.000V	Factory correction	○
F5-44	AI1 displayed voltage 2	-10.00V~10.000V	Factory correction	○
F5-45	AI2 measured voltage 1	-10.00V~10.000V	Factory correction	○
F5-46	AI2 displayed voltage 1	-10.00V~10.000V	Factory correction	○
F5-47	AI2 measured voltage 2	-10.00V~10.000V	Factory correction	○
F5-48	AI2 displayed voltage 2	-10.00V~10.000V	Factory correction	○
F5-49	AI3 measured voltage 1	-10.00V~10.000V	Factory correction	○
F5-50	AI3 displayed voltage 1	-10.00V~10.000V	Factory correction	○
F5-51	AI3 measured voltage 2	-10.00V~10.000V	Factory correction	○

F5-52	AI3 displayed voltage 2	-10.00V~10.000V	Factory correction	○
F5-53	AI2 current calibration measured current 1	0mA~20.000 mA	Factory correction	○
F5-54	AI2 current calibration displayed current 1	0mA~20.000 mA	Factory correction	○
F5-55	AI2 current calibration measured voltage current2	0mA~20.000 mA	Factory correction	○
F5-56	AI2 current calibration displayed current 2	0mA~20.000 mA	Factory correction	○

F6 group digital output terminal DO

F6-00	HDO terminal output mode selection	0: Pulse output (HDO) 1: Switch output (DO)	0	○
F6-01	HDO function selection (open collector output terminal)	0: No output 1: Drive running	0	○
F6-02	Control panel relay function selection Relay1	2: Fault output (fault of free stop) 3: Frequency level detection 1	2	○
F6-03	Reserved	4: Frequency reached		
F6-04	Control panel relay function selection Relay2	5: Running at zero speed (no output when stopping)	1	○
F6-05	Reserved	6: Motor overload pre-alarm 7: Drive overload pre-alarm 8: Set value reached 9: Designated value reached 10: Length reached 11: Simple PLC cycle completed 12: Cumulative running time reached 13: Frequency limiting 14: Torque limiting 15: Ready for running 16: AI1>AI2 17: Upper limiting frequency reached 18: Lower limiting frequency reached (without output when stopping) 19: Undervoltage state 20: Communication setting 21: Reserved 22: Reserved 23: Running at zero speed 2 (also output when stopping) 24: Cumulative power-on time reached 25: Frequency level detection 2 26: Frequency 1 reached 27: Frequency 2 reached 28: Current 1 reached 29: Current 2 reached 30: Timing overrun 31: AI1 input overrun 32: Unloading		

		33: In reverse running 34: Zero current state 35: Module temperature reached 36: Output current overrun 37: Lower limiting frequency reached (also output when stopping) 38: Alarm (all faults) 39: Motor over-temperature 40: Current running time reached 41: Fault (free stop fault and no output under voltage)		
F6-06	HDO output function selection	0: Operation frequency	0	○
F6-07	AO1 output function selection	1: Set frequency	0	○
F6-08	AO2 output function selection	2: Output current 3: Motor output torque (absolute value, percentage relative to motor) 4: Output power 5: Output voltage 6: Pulse input (100.0% for 100.0kHz) 7: AI1 8: AI2 9: AI3 (optional card) 10: Length 11: Countvalue 12: Communication setting 13: Motor speed 14: Output current (100.0% for 1000.0A) 15: Output voltage (100.0% for 1000.0V) 16: Motor output torque (actual value, percentage relative to motor)	1	○
F6-09	Maximum frequency of HDO output	0.01kHz~100.00kHz	50.00kHz	○
F6-10	AO1 zero bias coefficient	-100.0%~+100.0%	0.0%	○
F6-11	AO1 gain	-10.00~+10.00	1.00	○
F6-12	AO2 zero bias coefficient	-100.0%~+100.0%	0.0%	○
F6-13	AO2 gain	-10.00~+10.00	1.00	○
F6-14	Reserved			
F6-15	Reserved			
F6-16	Reserved			
F6-17	HDO output delay time	0.0s~3600.0s	0.0s	○
F6-18	RO1 output delay time	0.0s~3600.0s	0.0s	○
F6-19	DO1 output delay time	0.0s~3600.0s	0.0s	○
F6-20	RO2 output delay time	0.0s~3600.0s	0.0s	○
F6-21	DO2 output delay time	0.0s~3600.0s	0.0s	○
F6-22	Valid state selection of DO output terminal	0: Positive logic 1: Negative logic Units: HDO Tens: RO1 Hundreds: DO1 Thousands: RO2 Ten thousands: DO2	00000	○

F6-23	Reserved			
F6-24	AO1 target voltage 1	-10.00V~10.000V	Factory correction	○
F6-25	AO1 measured voltage 1	-10.00V~10.000V	Factory correction	○
F6-26	AO1 target voltage 2	-10.00V~10.000V	Factory correction	○
F6-27	AO1 measured voltage 2	-10.00V~10.000V	Factory correction	○
F6-28	AO2 target voltage 1	-10.00V~10.000V	Factory correction	○
F6-29	AO2 measured voltage 1	-10.00V~10.000V	Factory correction	○
F6-30	AO2 target voltage 2	-10.00V~10.000V	Factory correction	○
F6-31	AO2 measured voltage 2	-10.00V~10.000V	Factory correction	○
F6-32	AO2 current calibration measured current 1	0mA~20.000 mA	Factory correction	○
F6-33	AO2 current calibration displayed current 1	0mA~20.000 mA	Factory correction	○
F6-34	AO2 current calibration measured current 2	0mA~20.000 mA	Factory correction	○
F6-35	AO2 current calibration displayed current 2	0mA~20.000 mA	Factory correction	○

F7 group keyboard and display

F7-00	User password	0~65535	0	○
F7-01	Digital tube self-inspection	0: No inspection 1: All digital tubes are lit	0	○
F7-02	MF key function selection	0: MF invalid 1: Switch between the command channel of the operation panel and the remote command channel (terminal command channel Or communication command channel) switching 2: Forward and reverse running switching 3: Forward jog 4: Reverse jog	0	⊙
F7-03	STOP/RESET key function	0: Stop function of STOP/RES key is valid only in keyboard operation mode 1: Stop function of STOP/RST key is valid in any operation mode	1	○

F7-04	Running display parameter 1	0000~FFFF Bit00: Operating frequency 1(Hz) Bit01: Set frequency (Hz) Bit02: Bus voltage (V) Bit03: Output voltage (V) Bit04: Output current (A) Bit05: Output power (kW) Bit06: Output torque (%) Bit07: X input state Bit08: DO output state Bit09: AI1 voltage (V) Bit10: AI2 voltage (V) Bit11: AI3 voltage (V) Bit12: Count value Bit13: Length value Bit14: Load speed display Bit15: PID setting	1F	○
F7-05	Running display parameter 2	0000~FFFF Bit00: PID feedback Bit01: PLC stage Bit02: PULSE input frequency (kHz) Bit03: Feedback frequency Bit04: Remaining running time Bit05:AI1 voltage before correction (V) Bit06:AI2 voltage before correction (V) Bit07:AI3 voltage before correction (V) Bit08: Motor speed Bit09: Current power-on time (Hour) Bit10: Current running time (Min) Bit11: PULSE input frequency (Hz) Bit12: Communication setting value Bit13: Encoder feedback speed (Hz) Bit14: Main frequency X display (Hz) Bit15: Auxiliary frequency Y display (Hz)	0	○
F7-06	Stop display parameter	0000~FFFF Bit00: Set frequency (Hz) Bit01: Bus voltage (V) Bit02:X input state Bit03:DO output state Bit04:AI1 voltage (V) Bit05:AI2 voltage (V) Bit06:AI3 voltage (V) Bit07: Count value Bit08: Length value Bit09: PLC stage Bit10: Load speed Bit11: PID setting Bit12: PULSE input frequency (kHz)	33	○
F7-07	Load transmission ratio	0.001~6.5000	1.000	○

F7-08	Number of decimal places of load speed display	Units: Decimal place in U0-14 0: 0 decimal place 1: 1 decimal place 2: 2 decimal place 3: 3 decimal places Tens: Decimal place inU0-19/U0-29 1: 1 decimal place 2: 2 decimal place	21	○
F7-09	Display selection of function parameter group	Units: U group display selection 0: No display 1: Display Tens: A group display selection 0: No display 1: Display	11	●
F7-10	Display selection of personalized parameter group	Tens: Display selection of user-defined parameter group 0: No display 1: Display Tens: Display selection of user change parameter group 0: No display 1: Display	00	○
F7-11	Parameter modification attribute	0: Modifiable 1: Non-modifiable	0	○

F8 group enhanced function

F8-00	Jog operating frequency	0.00Hz ~ maximum frequency	2.00Hz	○
F8-01	Jog acceleration time	0.00s ~ 650.00s (F0-19=2) 0.0s ~ 6500.0s (F0-19=1) 0s ~ 65000s (F0-19=0)	20.0s	○
F8-02	Jog deceleration time	0.00s ~ 650.00s (F0-19=2) 0.0s ~ 6500.0s (F0-19=1) 0s ~ 65000s (F0-19=0)	20.0s	○
F8-03	Acceleration time 2	0.00s~650.00s (F0-19=2) 0.0s~6500.0s (F0-19=1) 0s~65000s (F0-19=0)	Model determination	○
F8-04	Deceleration time 2	0.00s~650.00s (F0-19=2) 0.0s~6500.0s (F0-19=1) 0s~65000s (F0-19=0)	Model determination	○
F8-05	Acceleration time 3	0.00s~650.00s (F0-19=2) 0.0s~6500.0s (F0-19=1) 0s~65000s (F0-19=0)	Model determination	○
F8-06	Deceleration time 3	0.00s~650.00s(F0-19=2) 0.0s~6500.0s(F0-19=1) 0s~65000s(F0-19=0)	Model determination	○
F8-07	Acceleration time 4	0.00s~650.00s(F0-19=2) 0.0s~6500.0s(F0-19=1) 0s~65000s(F0-19=0)	0.0s	○

F8-08	Deceleration time 4	0.00s~650.00s(F0-19=2) 0.0s~6500.0s(F0-19=1) 0s~65000s(F0-19=0)	0.0s	○
F8-09	Jump frequency 1	0.00Hz~ maximum frequency	0.00Hz	○
F8-10	Jump frequency 2	0.00Hz~ maximum frequency	0.00Hz	○
F8-11	Jump frequency amplitude	0.00Hz~ maximum frequency	0.00Hz	○
F8-12	Dead time of forward and reverse running	0.0s~3000.0s	0.0s	○
F8-13	Reverse frequency disabling	0: Invalid 1: Valid	0	○
F8-14	Set frequency lower than the lower limiting frequency operation mode	0: Run at the lower limiting frequency 1: Stop 2: Run at zero-speed	0	○
F8-15	Droop rate	0.00%~10.00%	0.00%	○
F8-16	Set cumulative power-on reaching time	0h~65000h	0h	○
F8-17	Set cumulative running reaching time	0h~65000h	0h	●
F8-18	Start protection selection	0: Unprotected 1: Protected	0	○
F8-19	Frequency detection value 1	0.00Hz~ maximum frequency	50.00Hz	○
F8-20	Frequency detection lag rate 1	0.0%~100.0%(FDT1 level)	5.0%	○
F8-21	Frequency reaching detection amplitude	0.0%~100.0% (maximum frequency)	0.0%	○
F8-22	Whether jump frequency in acceleration and deceleration process is valid	0: Invalid 1: Valid	0	○
F8-23	Reserved			○
F8-24	Reserved			○
F8-25	Acceleration time 1 and acceleration time 2 switching frequency point	0.00Hz~ maximum frequency	0.00Hz	○
F8-26	Deceleration time 1 and deceleration time 2 switching frequency point	0.00Hz~ maximum frequency	0.00Hz	○
F8-27	Terminal jog priority	0: Invalid 1: Valid	0	○
F8-28	Frequency detection value 2	0.00Hz~ maximum frequency	50.00Hz	○
F8-29	Frequency detection lag rate 2	0.0%~100.0%(FDT2 level)	5.0%	○
F8-30	Arbitrary reaching frequency detection value 1	0.00Hz~ maximum frequency	50.00Hz	○
F8-31	Arbitrary reaching frequency detection width 1	0.0%~100.0% (maximum frequency)	0.0%	○
F8-32	Arbitrary reaching frequency detection value 2	0.00Hz~ maximum frequency	50.00Hz	○
F8-33	Arbitrary reaching frequency detection width 2	0.0%~100.0% (maximum frequency)	0.0%	○
F8-34	Zero current detection level	0.0%~300.0% 100.0% corresponds to the rated voltage of motor	5.0%	○
F8-35	Zero current detection delay time	0.01s~600.00s	0.10s	○
F8-36	Output current overrun value	0.0% (not detected) 0.1%~300.0% (motor rated current)	200.0%	○

F8-37	Delay time of output current overrun detection	0.00s~600.00s	0.00s	○
F8-38	Arbitrary reaching current 1	0.0%~300.0% (motor rated current)	100.0%	○
F8-39	Arbitrary reaching current 1 amplitude	0.0%~300.0% (motor rated current)	0.0%	○
F8-40	Arbitrary reaching current 2	0.0%~300.0% (motor rated current)	100.0%	○
F8-41	Arbitrary reaching current 2 amplitude	0.0%~300.0% (motor rated current)	0.0%	○
F8-42	Selection of timing function	0: Invalid 1: Valid	0	●
F8-43	Time selection of timing run	0: F8-44 setting 1:A11 2:A12 3:A13 Analog input range corresponds to F8-44	0	●
F8-44	Timing run time	0.0Min~6500.0Min	0.0Min	●
F8-45	Lower limit of A11 input voltage protection value	0.00V~F8-46	3.10V	○
F8-46	Upper limit of A11 input voltage protection value	F8-45~10.00V	6.80V	○
F8-47	Module temperature reached	0°C ~100°C	75°C	○
F8-48	Cooling fan control	0: The fan runs when running 1: The fan keeps running	0	●
F8-49	Wake-up frequency	Sleep frequency (F8-51) ~ maximum frequency (F0-10)	0.00Hz	○
F8-50	Wake-up delay time	0.0s~6500.0s	0.0s	○
F8-51	Sleep frequency	0.00Hz~ wake-up frequency (F8-49)	0.00Hz	○
F8-52	Sleep delay time	0.0s~6500.0s	0.0s	○
F8-53	Current running time reached	0.0~6500.0 minutes	0.0Min	●
F8-54	Output power correction coefficient	0.00%~200.0%	100.0%	○
F8-55	DPWM switching upper limiting frequency	5.00Hz~ maximum frequency	8.00Hz	○
F8-56	PWM modulation mode	0: Asynchronous modulation 1: Synchronous modulation	0	○
F8-57	Dead-time compensation mode selection	0: No compensation 1: Compensation mode	1	○
F8-58	Random PWM depth	0: Random PWM invalid 1~10: Random depth of PWM carrier frequency	0	○
F8-59	Fast current limiting enabled	0: Disable 1: Enable	1	○
F8-60	Voltage over-modulation coefficient	100~110	105	●
F8-61	Undervoltage point setting	380V model: 150.0V~420.0V 220V model: 150.0V~420.0V		○
F8-62	Reserved			
F8-63	Reserved			
F8-64	Overvoltage point setting	380V model: 330.0V~820.0V 220V model: 330.0V~400.0V		●
F8-65	Reserved			

F8-66	Energy consumption braking lower limiting voltage			
F8-67 ~ F8-74	Reserved			

F9 group PID function				
F9-00	PID set source	0:F9-01setting 1:A11 2:A12 3:A13 4: Pulse setting (HDI) 5: Communication setting 6: Multi-segment instruction setting	0	○
F9-01	PID digital setting	0.0%~100.0%	50.0%	○
F9-02	PID feedback source	0:A11 1:A12 2:A13 3:A11-A12 4: Pulse setting (HDI) 5: Communication setting 6:A11+A12 7:MAX (A11 , A12) 8: MIN (A11 , A12)	0	○
F9-03	PID effect direction	0: Positive effect 1: Negative effect	0	○
F9-04	PID set feedback range	0~65535	1000	○
F9-05	Proportional gain Kp1	0.0~1000.0	20.0	○
F9-06	Integration time Ti1	0.01s~10.00s	2.00s	○
F9-07	Differential time Td1	0.000s~10.000s	0.000s	○
F9-08	PID inversion cutoff frequency	0.00Hz~ Maximum frequency	0.00Hz	○
F9-09	PID deviation limit	0.0%~100.0%	0.0%	○
F9-10	PID differential amplitude limit	0.00%~100.00%	0.10%	○
F9-11	PID set change time	0.00~650.00s	0.00s	○
F9-12	PID feedback filtering time	0.00~60.00s	0.00s	○
F9-13	PID output filtering time	0.00~60.00s	0.00s	○
F9-14	Reserved	-	-	○
F9-15	Proportional gain Kp2	0~1000.0	20.0	○
F9-16	Integration time Ti2	0.01s~10.00s	2.00s	○
F9-17	Differential time Td2	0.000s~10.000s	0.000s	○
F9-18	PID parameter switching condition	0: Not switched 1: Switch through X terminal 2: Automatic switching according to deviation 3: Automatic switching according to operating frequency	0	○
F9-19	PID parameter switching deviation 1	0.0%~F9-20	20.0%	○
F9-20	PID parameter switching deviation 2	F9-19~100.0%	80.0%	○
F9-21	PID initial value	0.0%~100.0%	0.0%	○
F9-22	PID initial value holding time	0.00~650.00s	0.00s	○

F9-23	Maximum positive deviation of two outputs	(0.00 ~ 100.00)%	1.00%	○
F9-24	Maximum negative deviation of two outputs	(0.00 ~ 100.00)%	1.00%	○
F9-25	PID integral attribute	Units: Integral separation 0: Invalid 1: Valid Tens: Whether to stop integrating after the output reaches the limit value 0: Continue integration 1: Stop integration	00	○
F9-26	PID feedback loss detection value	0.0%: feedback loss is not judged 0.1%~100.0%	0.0%	○
F9-27	PID feedback loss detection time	0.0s~20.0s	0.0s	○
F9-28	PID stop with operation	0: No operation when stopping 1: Operation when stopping	0	○
F9-29	PID overshoot detection value	0.0%: feedback overshoot is not judged 0.1%~100%	0.0%	○
F9-30	PID overshoot detection time	0.0s~20.0s	0.0s	○
F9-31	Reserved			
F9-32	Reserved			
F9-33	Reserved			
F9-34	Set length	0m~65535m	1000m	○
F9-35	Actual length	0m~65535m	0m	○
F9-36	Pulse number per meter	0.1~6553.5	100	○
F9-37	Set count value	1~65535	1000	○
F9-38	Designated count value	1~65535	1000	○

FA group multi-segment instruction, simple PLC

FA-00	Multi-segment instruction 0	-100.0%~100.0%	0.0%	○
FA-01	Multi-segment instruction 1	-100.0%~100.0%	0.0%	○
FA-02	Multi-segment instruction 2	-100.0%~100.0%	0.0%	○
FA-03	Multi-segment instruction 3	-100.0%~100.0%	0.0%	○
FA-04	Multi-segment instruction 4	-100.0%~100.0%	0.0%	○
FA-05	Multi-segment instruction 5	-100.0%~100.0%	0.0%	○
FA-06	Multi-segment instruction 6	-100.0%~100.0%	0.0%	○
FA-07	Multi-segment instruction 7	-100.0%~100.0%	0.0%	○
FA-08	Multi-segment instruction 8	-100.0%~100.0%	0.0%	○
FA-09	Multi-segment instruction 9	-100.0%~100.0%	0.0%	○
FA-10	Multi-segment instruction 10	-100.0%~100.0%	0.0%	○
FA-11	Multi-segment instruction 11	-100.0%~100.0%	0.0%	○
FA-12	Multi-segment instruction 12	-100.0%~100.0%	0.0%	○
FA-13	Multi-segment instruction 13	-100.0%~100.0%	0.0%	○
FA-14	Multi-segment instruction 14	-100.0%~100.0%	0.0%	○
FA-15	Multi-segment instruction 15	-100.0%~100.0%	0.0%	○
FA-16	Simple PLC running mode	0: Stop at the end of single running 1: Keep the final value at the end of single running 2: Keep circulating	0	○

FA-17	Simple PLC power-off memory selection	Units: Power-off memory selection 0: No power-off memory 1: Power-off memory Tens: Stop memory selection 0: No stop memory 1: Stop memory	00	○
FA-18	Running time of simple PLCsegment 0	0.0s(h)~6553.5s(h)	0.0s(h)	○
FA-19	Selection of acceleration and deceleration time in simple PLC segment 0	0~3 0: Acceleration and deceleration time1 1: Acceleration and deceleration time 2 2: Acceleration and deceleration time 3 3: Acceleration and deceleration time 4	0	○
FA-20	Running time of simple PLCsegment 1	0.0s(h)~6500.0s(h)	0.0s(h)	○
FA-21	Selection of acceleration and deceleration time in simple PLC segment 1	Same asFA-19	0	○
FA-22	Running time of simple PLCsegment 2	0.0s(h)~6500.0s(h)	0.0s(h)	○
FA-23	Selection of acceleration and deceleration time in simple PLC segment 2	Same asFA-19	0	○
FA-24	Running time of simple PLCsegment 3	0.0s(h)~6500.0s(h)	0.0s(h)	○
FA-25	Selection of acceleration and deceleration time in simple PLC segment 3	Same asFA-19	0	○
FA-26	Running time of simple PLCsegment 4	0.0s(h)~6500.0s(h)	0.0s(h)	○
FA-27	Selection of acceleration and deceleration time in simple PLC segment 4	Same asFA-19	0	○
FA-28	Running time of simple PLCsegment 5	0.0s(h)~6500.0s(h)	0.0s(h)	○
FA-29	Selection of acceleration and deceleration time in simple PLC segment 5	Same asFA-19	0	○
FA-30	Running time of simple PLCsegment 6	0.0s(h)~6500.0s(h)	0.0s(h)	○
FA-31	Selection of acceleration and deceleration time in simple PLC segment 6	Same asFA-19	0	○
FA-32	Running time of simple PLCsegment 7	0.0s(h)~6500.0s(h)	0.0s(h)	○
FA-33	Selection of acceleration and deceleration time in simple PLC segment 7	Same asFA-19	0	○

FA-34	Running time of simple PLCsegment 8	0.0s(h)~6500.0s(h)	0.0s(h)	○
FA-35	Selection of acceleration and deceleration time in simple PLC segment 8	Same asFA-19	0	○
FA-36	Running time of simple PLCsegment 9	0.0s(h)~6500.0s(h)	0.0s(h)	○
FA-37	Selection of acceleration and deceleration time in simple PLC segment 9	Same asFA-19	0	○
FA-38	Running time of simple PLCsegment 10	0.0s(h)~6500.0s(h)	0.0s(h)	○
FA-39	Selection of acceleration and deceleration time in simple PLC segment 10	0~3 Same asFA-19	0	○
FA-40	Running time of simple PLCsegment 11	0.0s(h)~6500.0s(h)	0.0s(h)	○
FA-41	Selection of acceleration and deceleration time in simple PLC segment 11	Same asFA-19	0	○
FA-42	Running time of simple PLCsegment 12	0.0s(h)~6500.0s(h)	0.0s(h)	○
FA-43	Selection of acceleration and deceleration time in simple PLC segment 12	Same asFA-19	0	○
FA-44	Running time of simple PLCsegment 13	0.0s(h)~6500.0s(h)	0.0s(h)	○
FA-45	Selection of acceleration and deceleration time in simple PLC segment 13	Same asFA-19	0	○
FA-46	Running time of simple PLCsegment 14	0.0s(h)~6500.0s(h)	0.0s(h)	○
FA-47	Selection of acceleration and deceleration time in simple PLC segment 14	Same asFA-19	0	○
FA-48	Running time of simple PLCsegment 15	0.0s(h)~6500.0s(h)	0.0s(h)	○
FA-49	Selection of acceleration and deceleration time in simple PLC segment 15	Same asFA-19	0	○
FA-50	Simple PLC running time unit	0: s(second) 1:h(hour)	0	○
FA-51	Multi-segment instruction 0 set mode	0: ParameterFA-00setting 1:A11 2:A12 3:A13 4: Pulse 5: PID 6Preset frequency (F0-08) setting, and UP/DOWN modifiable	0	○

FC group (reserved)

Fb group communication parameters				
Fb-00	Communication protocol selection	0: Modbus protocol 1: Profibus-DP, CANopen, Profinet, EtherCAT protocol	0	◦
Fb-01	Communication baud rate	Units: MODBUS 0:300BPS 1:600BPS 2:1200BPS 3:2400BPS 4:4800BPS 5:9600BPS 6:19200BPS 7:38400BPS 8:57600BPS 9:115200BPS Tens: Profibus-DP 0:115200BPS 1:208300BPS 2:256000BPS 3:512000BpS Hundreds: reserved Thousands: CANlink baud rate 0:20 1:50 2:100 3:125 4:250 5:500 6:1M	5005	◦
Fb-02	MODBUS data format	0: No parity (8-N-2) 1: Even parity (8-E-1) 2: Odd parity (8-O-1) 3: No parity (8-N-1) (MODBUS valid)	0	◦
Fb-03	Local address	0: Broadcast address 1 ~ 247 (Modbus, Profibus-DP, CANlink, Profinet, EtherCAT valid)	1	◦
Fb-04	MODBUS response delay	0~20ms (MODBUS valid)	2	◦
Fb-05	Time of serial communication timeout	0.0: Invalid 0.1 ~ 60.0s (Modbus, Profibus-DP, CANopen, Profinet, EtherCAT valid)	0.0	◦
Fb-06	Data transmission format selection	Units: Modbus 0: Non-standard Modbus protocol 1: Standard Modbus protocol	1	◦
Fb-07	Communication read current resolution	0:0.01A(valid when≤ 55kW) 1:0.1A	0	◦
Fb-08	Reserved			
Fb-09	Profibus-DP, CANopen, Profinet, EtherCAT communication interruption detection time	0.0s: Invalid 0.1~60.0s	0	◦
Fb-10	Reserved			

FD group optional card				
Fd-00	Number of encoder lines	1~65535	1024	●
Fd-01	Encoder type	0: ABZ incremental encoder 2: Resolver	0	●
Fd-02	Reserved			
Fd-03	ABZ incremental encoder AB phase sequence	0: Forward 1: Reverse	0	●
Fd-04	Reserved			
Fd-05	Reserved			
Fd-06	Reserved			
Fd-07	Pole pairs of resolver	1~65535	1	●
Fd-08	Reserved			
Fd-09	Speed feedback PG disconnection detection time	0.0s: No action 0.1s~10.0s	0.0s	●
Fd-10 ~ Fd-19	Reserved			

FE group fault and protection				
FE-00	Motor overload protection selection	0: Disabled 1: Enabled	1	○
FE-01	Motor overload protection gain	0.20~10.00	1.00	○
FE-02	Motor overload warning coefficient	50%~100%	80%	○
FE-03	Overvoltage stall gain	0~100	30	○
FE-04	Overvoltage stall protection voltage	380Vmodel:650.0V~800.0V 220Vmodel:320.0V~800.0V	380V model: 760V 220V model: 380V	●
FE-05	Reserved			
FE-06	Reserved			
FE-07	Selection of short-circuit protection to ground	Selection of power-on short-circuit protection to ground 0: Invalid 1: Valid Tens: Selection of short circuit protection to ground before operation 0: Invalid 1: Valid	1	○
FE-08	Starting voltage of braking unit action	380V model: 650.0V~800.0V 220V model: 320.0V~800.0V	380V model: 690V 220V model: 360V	○
FE-09	Fault automatic reset times	0~30	0	○
FE-10	Fault during automatic fault reset DO Action selection	0: No action 1: Action	1	○
FE-11	Fault automatic reset waiting time	0.1s~100.0s	6.0s	○

FE-12	Selection of input open-phase\contactor connection protection	Units: Input open-phase protection selection 0: Input open-phase protection disabled 1: Simultaneous detection of software and hardware input open-phase protection 2: Enable software input open-phase protection 3: Enable hardware input open-phase protection Tens: Contactor connection protection selection 0: Disabled 1: Enabled	11	○
FE-13	Output open-phase protection selection	Units: Output open-phase protection selection 0: Disabled 1: Enabled Tens: Selection of output open-phase protection before operation 0: Disabled 1: Enabled	01	○
FE-14	Type of the first fault	0: No fault	-	●
FE-15	Type of the second fault	1: Reserved	-	●
FE-16	Type of the third (latest) fault type	2: Accelerated overcurrent 3: Decelerated overcurrent 4: Constant speed overcurrent 5: Accelerated overvoltage 6: Decelerated overvoltage 7: Constant speed overvoltage 8: Buffer resistor overload 9: Undervoltage 10: Drive overload 11: Motor overload 12: Input open-phase 13: Output open-phase 14: Module overheating 15: External fault 16: Abnormality in communication 17: Abnormality in contactor 18: Abnormality in current detection 19: Abnormality in motor tuning 20: Abnormality in encoder /PG card 21: Abnormality in parameter reading and writing 22: Abnormality in converter hardware 23: Motor short circuit to ground 24: Run-time PID overshoot 25: Reserved 26: Running time reached 27: User-defined fault 1 28: User-defined fault 2 29: Power-on time reached 30: Unloading 31: PID feedback loss during running 40: Wave-by-wave current limiting fault 41: Switching motor during running 42: Excessive speed deviation	-	●

		43: Motor overspeed 45: Motor over-temperature 51: Initial position error 55: Slave fault in master-slave control 61: Braking unit overload 62: Brake circuit is short		
FE-17	Frequency at the third (latest) fault	0.00Hz~655.35Hz	0.00Hz	●
FE-18	Current at the third (latest) fault	0.00A~655.35A	0.00A	●
FE-19	Bus voltage at the third (latest) fault	0.0V~6553.5V	0.0V	●
FE-20	Input terminal state at the third (latest) fault	0~9999	0	●
FE-21	Output terminal state at the third (latest) fault	0~9999	0	●
FE-22	Drive state at the third (latest) fault	0~65535	0	●
FE-23	Power-on time at the third (latest) fault	0s~65535s	0s	●
FE-24	Running time at the third (latest) fault	0.0s~6553.5s	0.0s	●
FE-25	Reserved			
FE-26	Reserved			
FE-27	Frequency at the second fault	0.00Hz~655.35Hz	0.00Hz	●
FE-28	Current at the second fault	0.00A~655.35A	0.00A	●
FE-29	Bus voltage at the second fault	0.0V~6553.5V	0.0V	●
FE-30	Input terminal state at the second fault	0~9999	0	●
FE-31	Output terminal state at the second fault	0~9999	0	●
FE-32	Drive state at the second fault	0~65535	0	●
FE-33	Power-on time at the second fault	0s~65535s	0s	●
FE-34	Running time at the second fault	0.0s~6553.5s	0.0s	●
FE-35	Reserved			
FE-36	Reserved			
FE-37	Frequency at the first fault	0.00Hz~655.35Hz	0.00Hz	●
FE-38	Current at the first fault	0.00A~655.35A	0.00A	●
FE-39	Bus voltage at the first fault	0.0V~6553.5V	0.0V	●
FE-40	Input terminal state at the first fault	0~9999	0	●
FE-41	Output terminal state at the first fault	0~9999	0	●
FE-42	Drive state at the first fault	0~65535	0	●
FE-43	Power-on time at the first fault	0s~65535s	0s	●
FE-44	Running time at the first fault	0.0s~6553.5s	0.0s	●
FE-45	Reserved			
FE-46	Reserved			

FE-47	Fault protection action selection 1	<p>Units: Motor overload (E.OL1)</p> <p>0: Free stop</p> <p>1: Stop by stopping mode</p> <p>2: Continue running</p> <p>Tens: Input open-phase (E.SPI)(same as units)</p> <p>Hundreds: Output open-phase (E.SPO) (same as units)</p> <p>Thousands: External fault (E.EF) (same as units)</p> <p>Ten thousands: Communication abnormality (E.CE) (same as units)</p>	00000	○
FE-48	Fault protection action selection 2	<p>Units: Abnormality in encoder /PG card (E.ENCD)</p> <p>0: Free stop</p> <p>Tens: Abnormality in parameter reading and writing (E.EEP)</p> <p>0: Free stop</p> <p>1: Stop by stopping mode</p> <p>Hundreds: Run-time PID feedback overshoot (E.FBH) (same as FE-47 units)</p> <p>Thousands: Reserved</p> <p>Ten thousands: Running time reached (E.RTO)</p>	00000	○
FE-49	Fault protection action selection 3	<p>Units: User-defined fault 1(E.US1)</p> <p>0: Free stop</p> <p>1: Stop by stopping mode</p> <p>2: Continue running</p> <p>Tens: User-defined fault 2(E.US2)</p> <p>0: Free stop</p> <p>1: Stop by stopping mode</p> <p>2: Continue running</p> <p>Hundreds: Power-on time reached (E.PTO)</p> <p>0: Free stop</p> <p>1: Stop by stopping mode</p> <p>2: Continue running</p> <p>Thousands: Unloading (E.LL)</p> <p>0: Free stop</p> <p>1: Stop by deceleration</p> <p>2: Directly jump to 7% of the rated frequency of the motor to continue running, and automatically return to the set frequency when not unloading</p> <p>Ten thousands: PID feedback loss during running (E.FBL)</p> <p>0: Free stop</p> <p>1: Stop by stopping mode</p> <p>2: Continue running</p>	00000	○
FE-50	Fault protection action selection 4	<p>Units: Excessive speed deviation (E.DEV)</p> <p>0: Free stop</p> <p>1: Stop by stopping mode</p> <p>2: Continue running</p> <p>Tens: Motor overspeed (E.OS)</p> <p>Hundreds: Initial position error (E.POS) (same as units)</p>	00000	○
FE-51	Reserved			

FE-52	Reserved			
FE-53	Reserved			
FE-54	Selection of continuous operating frequency in case of fault	0: Run at current operating frequency 1: Run at the set frequency 2: Run at the upper limiting frequency 3: Run at the lower limiting frequency 4: Run at abnormal standby frequency	0	○
FE-55	Abnormal standby frequency	0.0%~100.0% (100.0% for the maximum frequency F0-10)	100.0%	○
FE-56	Motor temperature sensor type	0: No temperature sensor 1:PT100 2:PT1000	0	○
FE-57	Motor overheat protection threshold	0°C ~200°C	110°C	○
FE-58	Motor overheat pre-alarm threshold	0°C ~200°C	90°C	○
FE-59	Selection of instantaneous stop failure function	0~2 0: Invalid 1: Bus voltage constant control 2: Stop by deceleration	0	●
FE-60	Recovery voltage for instantaneous stop failure	80%~100%	85%	●
FE-61	Judgment time of instantaneous stop failure voltage recovery	0.0~100.0s	0.5S	●
FE-62	Judgment voltage of instantaneous stop failure action	60%~100%	80%	●
FE-63	Instantaneous stop failure gain Kp	0~100	40	○
FE-64	Instantaneous stop integration coefficient Ki	0~100	30	○
FE-65	Deceleration time of instantaneous stop failure action	0~300.0s	20.0s	●
FE-66	Unloading protection selection	0: Invalid 1: Valid	0	○
FE-67	Unloading detection level	0.0~100.0%	10.0%	○
FE-68	Unloading detection time	0.0~60.0s	1.0s	○
FE-69	Reserved			
FE-70	Overspeed detection value	0.0% ~50.0% (maximum frequency)	20.0%	○
FE-71	Overspeed detection time	0.0s: Not detected 0.1~60.0s	1.0s	○
FE-72	Detection value of excessive speed deviation	0.0% ~50.0% (maximum frequency)	20.0%	○
FE-73	Detection time of excessive speed deviation	0.0s: Not detected 0.1~60.0s	5.0s	○
FE-74	Software input open-phase sensitivity	1 ~ 50	5	○
FE-75	Software input open-phase filtering	1 ~ 50	20	○
FE-76	Reserved			
FE-77	Reserved			
FE-78	Reserved			
FE-79	Reserved			
FE-80	Reserved			

FF group user-defined parameter				
FF-00	User parameter 0	F0-00~FE-xx A0-00~A5-xx U0-00~U0-xx	F0.00	○
FF-01	User parameter 1		F0.00	○
FF-02	User parameter 2		F0.00	○
FF-03	User parameter 3		F0.00	○
FF-04	User parameter 4		F0.00	○
FF-05	User parameter 5		F0.00	○
FF-06	User parameter 6		F0.00	○
FF-07	User parameter 7		F0.00	○
FF-08	User parameter 8		F0.00	○
FF-09	User parameter 9		F0.00	○
FF-10	User parameter 10		F0.00	○
FF-11	User parameter 11		F0.00	○
FF-12	User parameter 12		F0.00	○
FF-13	User parameter 13		F0.00	○
FF-14	User parameter 14		F0.00	○
FF-15	User parameter 15		F0.00	○
FF-16	User parameter 16		F0.00	○
FF-17	User parameter 17		F0.00	○
FF-18	User parameter 18		F0.00	○
FF-19	User parameter 19		F0.00	○
FF-20	User parameter 20		U0-68	○
FF-21	User parameter 21		U0-69	○
FF-22	User parameter 22		F0.00	○
FF-23	User parameter 23		F0.00	○
FF-24	User parameter 24		F0.00	○
FF-25	User parameter 25		F0.00	○
FF-26	User parameter 26		F0.00	○
FF-27	User parameter 27		F0.00	○
FF-28	User parameter 28		F0.00	○
FF-29	User parameter 29		F0.00	○
FF-30	User parameter 30		F0.00	○
FF-31	User parameter 31	F0.00	○	

A0 group terminal function expansion				
A0-00	Minimum input of AI curve 4	-10.00V~A0-02	0.00V	○
A0-01	Minimum input corresponding setting of AI curve 4	-100.0%~+100.0%	0.0%	○
A0-02	Input of AI curve 4 inflection point 1	A0-00~A0-04	3.00V	○
A0-03	Input corresponding setting for AI curve 4 inflection point 1	-100.0%~+100.0%	30.0%	○
A0-04	Input of AI curve 4 inflection point 2	A0-02~A0-06	6.00V	○
A0-05	Input corresponding setting for AI curve 4 inflection point 2	-100.0%~+100.0%	60.0%	○
A0-06	Maximum input of AI curve 4	A0-04~+10.00V	10.00V	○

A0-07	Maximum input corresponding setting of AI curve 4	-100.0%~+100.0%	100.0%	○
A0-08	Minimum input of AI curve 5	-10.00V~A0-10	-10.00V	○
A0-09	Minimum input corresponding setting of AI curve 5	-100.0%~+100.0%	-100.0%	○
A0-10	Input of AI curve 5 inflection point 1	A0-08~A0-12	-3.00V	○
A0-11	Input corresponding setting for AI curve 5 inflection point 1	-100.0%~+100.0%	-30.0%	○
A0-12	Input of AI curve 5 inflection point 2	A0-10~A0-14	3.00V	○
A0-13	Input corresponding setting for AI curve 5 inflection point 2	-100.0%~+100.0%	30.0%	○
A0-14	Maximum input of AI curve 5	A0-12~+10.00V	10.00V	○
A0-15	Maximum input corresponding setting of AI curve 5	300.00%	100.0%	○
A0-16 ~ A0-23	Reserved			
A0-24	AI1 set jump point	-100.0%~100.0%	0.0%	○
A0-25	AI1 set jump amplitude	0.0%~100.0%	0.1%	○
A0-26	AI2 set jump point	-100.0%~100.0%	0.0%	○
A0-27	AI2 set jump amplitude	0.0%~100.0%	0.1%	○
A0-28	AI3 set jump point	-100.0%~100.0%	0.0%	○
A0-29	AI3 set jump amplitude	0.0%~100.0%	0.1%	○
A0-30	Virtual VDI1 terminal function selection	0~59	0	⊗
A0-31	Virtual VDI2 terminal function selection	0~59	0	⊗
A0-32	Virtual VDI3 terminal function selection	0~59	0	⊗
A0-33	Virtual VDI4 terminal function selection	0~59	0	⊗
A0-34	Virtual VDI5 terminal function selection	0~59	0	⊗
A0-35	Virtual VDI terminal valid state setting mode	Units: Virtual VDI1	0	⊗
		Tens: Virtual VDI2		
		Hundreds: Virtual VDI3		
		Thousands: Virtual VDI4		
		Ten thousands: Virtual VDI5		
		0: Whether VDI is valid or not is determined by the state of virtual VDOx 1: Whether VDI is valid or not is set by parameter A0-36		
A0-36	Virtual VDI terminal state setting	0: invalid 1: valid	0	⊗
		Units: Virtual VDI1		
		Tens: Virtual VDI2		
		Hundreds: Virtual VDI3		
		Thousands: Virtual VDI4		
		Ten thousands: Virtual VDI5		

A0-37	Function selection when AI1 terminal is used as DI	0~59	0	●
A0-38	Function selection when AI2 terminal is used as DI	0~59	0	●
A0-39	Function selection when AI3 terminal is used as DI	0~59	0	●
A0-40	Valid mode when AI terminal is used as DI	0: High level valid	0	●
		1: Low level valid		
		Units: AI1		
		Tens: AI2		
		Hundreds: AI3		
A0-41	Virtual VDO1 output function selection	0: Short circuit with physical DIx inside 1~41: See F6 group physical DO output selection	0	○
A0-42	Virtual VDO2 output function selection	0: Short circuit with physical DIx inside 1~41: See F6 group physical DO output selection	0	○
A0-43	Virtual VDO3 output function selection	0: Short circuit with physical DIx inside 1~41: See F6 group physical DO output selection	0	○
A0-44	Virtual VDO4 output function selection	0: Short circuit with physical DIx inside 1~41: See F6 group physical DO output selection	0	○
A0-45	Virtual VDO5 output function selection	0: Short circuit with physical DIx inside 1~41: See F6 group physical DO output selection	0	○
A0-46	VDO1 output delay time	0.0s~3600.0s	0.0s	○
A0-47	VDO2 output delay time	0.0s~3600.0s	0.0s	○
A0-48	VDO3 output delay time	0.0s~3600.0s	0.0s	○
A0-49	VDO4 output delay time	0.0s~3600.0s	0.0s	○
A0-50	VDO5 output delay time	0.0s~3600.0s	0.0s	○
A0-51	VDO output terminal valid	0: Positive logic	0	○
		1: Negative logic		
		Units: VDO1		
		Tens: VDO2		
		Hundreds: VDO3		
		Thousands: VDO4		
		Ten thousands: VDO5		

A5 group second motor parameters

A5-00	Motor type selection	0: Normal asynchronous motor 1: Frequency conversion asynchronous motor	0	●
A5-01	Rated power of motor	0.1kW~6553.5kW	Model determination	●
A5-02	Rated voltage of motor	1V~2000V	Model determination	●
A5-03	Rated current of motor	0.01A~655.35A (drive power ≤55kW) 0.1A~6553.5A (drive power >55kW)	Model determination	●
A5-04	Rated frequency of motor	0.01Hz~maximum frequency	Model determination	●
A5-05	Rated speed of motor	1rpm~65535rpm	Model determination	●
A5-06	Stator resistance of asynchronous motor	0.001Ω~65.535Ω (drive power ≤55kW) 0.0001Ω~6.5535Ω (drive power >55kW)	Tuning parameter	●

A5-07	Rotor resistance of asynchronous motor	0.001Ω~65.535Ω (drive power ≤55kW) 0.0001Ω~6.5535Ω (drive power >55kW)	Tuning parameter	●
A5-08	Leakage inductance of asynchronous motor	0.01mH~655.35mH (drive power ≤55kW) 0.001mH~65.535mH (drive power >55kW)	Tuning parameter	●
A5-09	Mutual inductance of asynchronous motor	0.1mH~6553.5mH (drive power ≤ 55kW) 0.01mH~655.35mH (drive power >55kW)	Tuning parameter	●
A5-10	No-load current of asynchronous motor	0.01A~F1-03 (drive power ≤ 55kW) 0.1A~F1-03 (drive power >55kW)	Tuning parameter	●
A5-11 A5-26	Reserved			
A5-27	Number of encoder lines	1~65535	1024	●
A5-28	Encoder type	0: ABZ incremental encoder 2: Resolver	0	●
A5-29	Reserved			
A5-30	ABZ incremental encoder AB phase sequence	0: Forward 1: Reverse	0	●
A5-31	Reserved			
A5-32	Reserved			
A5-33	Reserved			
A5-34	Pole pairs of resolver	1~65535	1	●
A5-35	Reserved			
A5-36	Speed feedback PG disconnection detection time	0.0s: No action 0.1s~10.0s	0.0s	○
A5-37	Tuning selection	0: No operation 1: Static part parameter tuning of asynchronous machine 2: Dynamic complete tuning of asynchronous machine 3: Static complete tuning of asynchronous machine	0	●
A5-38	Speed loop proportional gain 1	1~100	30	○
A5-39	Speed loop integration time 1	0.01s~10.00s	0.50s	○
A5-40	Switching frequency 1	0.00~A5-43	5.00Hz	○
A5-41	Speed loop proportional gain 2	1~100	20	○
A5-42	Speed loop integration time 2	0.01s~10.00s	1.00s	○
A5-43	Switching frequency 2	A5-40~ Maximum frequency	10.00Hz	○
A5-44	Vector control slip gain	50%~200%	100%	○
A5-45	SVC speed feedback filtering time	0.000s~1.000s	0.050s	○
A5-46	Reserved			
A5-47	Instruction selection of torque upper limit in speed control mode	0: Parameter A5-48 setting 1: A11 2: A12 3: A13 4: HDI 5: Communication setting 6: MIN(A11,A12) 7: MAX(A11,A12) The full scale of options 1-7 corresponds to A5-48	0	○

A5-48	Digital setting of torque upper limit in speed control mode	0.0%~200.0%	150.00%	○
A5-49	Instruction selection of torque upper limit in speed control mode (power generation)	0: Parameter A5-47 setting (no distinction between motoring and power generation) 1: AI1 2: AI2 3: AI3 4: Pulse setting 5: Communication setting 6: MIN(AI1,AI2) 7: MAX(AI1,AI2) 8: Parameter A5-50 setting The full scale of options 1-7 corresponds to A5-50	0	○
A5-50	Digital setting of torque upper limit in speed control mode (power generation)	0.0% ~ 200.0%	150.00%	○
A5-51	Excitation regulation proportional gain	0~60000	2000	○
A5-52	Excitation regulation integral gain	0~60000	1300	○
A5-53	Torque regulation proportional gain	0~60000	2000	○
A5-54	Torque regulation integral gain	0~60000	1300	○
A5-55	Speed loop integral attribute	Units: Integral separation 0: invalid 1: valid	0	○
A5-56	Reserved			
A5-57	Reserved			
A5-58	Reserved			
A5-59	Reserved			
A5-60	Power generation limit enabled	0: invalid 1: Whole-process valid	0	●
A5-61	Upper limit of power generation	0.0~200.0%	Model determination	○
A5-62	The second motor control mode	0: Sensorless Vector Control (SVC) 1: Flux Vector Control (FVC) 2: V/F Control	0	●
A5-63	Selection of acceleration and deceleration time of motor 2	0: Same as the first motor 1: Acceleration and deceleration time 1 2: Acceleration and deceleration time 2 3: Acceleration and deceleration time 3 4: Acceleration and deceleration time 4	0	○
A5-64	Torque boost of the second motor	0.0%: Automatic torque boost 0.1% ~ 30.0%	Model determination	○
A5-65	Reserved			○
A5-66	Oscillation suppression gain of the second motor	0 ~100	Model determination	○

U0 group basic monitoring parameter			
Parameters	Name	Minimum unit	Mailing address
U0-00	Operating frequency (Hz)	0.01Hz	7000H
U0-01	Set frequency (Hz)	0.01Hz	7001H
U0-02	Bus voltage (V)	0.1V	7002H
U0-03	Output voltage (V)	1V	7003H
U0-04	Output current (A)	0.01A (drive power ≤55kW) 0.1A (drive power > 55kW)	7004H
U0-05	Output power (kW)	0.1kW	7005H
U0-06	Output torque (%)	0.1%	7006H
U0-07	X input state	1	7007H
U0-08	DO output state	1	7008H
U0-09	AI1 voltage (V)	0.01V	7009H
U0-10	AI2 voltage (V)/ current (mA)	0.01V/0.01mA	700AH
U0-11	AI3 voltage (V)	0.01V	700BH
U0-12	Count value	1	700CH
U0-13	Length value	1	700DH
U0-14	Load speed	1RPM	700EH
U0-15	PID setting	1	700FH
U0-16	PID feedback	1	7010H
U0-17	PLC stage	1	7011H
U0-18	Input pulse frequency (Hz)	0.01kHz	7012H
U0-19	Feedback speed (Hz)	0.01Hz	7013H
U0-20	Remaining running time	0.1Min	7014H
U0-21	AI1 voltage before correction	0.001V	7015H
U0-22	AI2 voltage before correction (V)	0.001V	7016H
U0-23	AI3 voltage before correction	0.001V	7017H
U0-24	Motor speed	1RPM	7018H
U0-25	Current power-on time	1Min	7019H
U0-26	Current running time	0.1Min	701AH
U0-27	Input frequency of pulse	1Hz	701BH
U0-28	Communication set value	0.01%	701CH
U0-29	Encoder feedback speed	0.01Hz	701DH
U0-30	Main frequency display	0.01Hz	701EH
U0-31	Auxiliary frequency display	0.01Hz	701FH
U0-32	Reserved		
U0-33	Reserved		
U0-34	Motor temperature value	1°C	7022H
U0-35	Target torque (%)	0.1%	7023H
U0-36	Resolver position	1	7024H
U0-37	Power factor angle	0.1°	7025H
U0-38	ABZ position	1	7026H
U0-39	V/F separation target voltage	1V	7027H
U0-40	V/F separation output voltage	1V	7028H
U0-41	Visual display of X input state	1	7029H
U0-42	Visual display of DO output state	1	702AH
U0-43	Visual display 1 of X function state (function 01-40)	1	702BH
U0-44	Visual display 2 of X function state (function 41-80)	1	702CH

U0-45	Reserved		
U0-46	Reserved		
U0-47	Reserved		
U0-48	Reserved		
U0-49	Reserved		
U0-50	Reserved		
U0-51	Reserved		
U0-52	Reserved		
U0-53	Reserved		
U0-54	Reserved		
U0-55	Reserved		
U0-56	Reserved		
U0-57	Reserved		
U0-58	Z signal counter	1	703AH
U0-59	Set frequency (%)	0.01%	703BH
U0-60	Operating frequency (%)	0.01%	703CH
U0-61	Drive state	1	703DH
U0-62	Current fault coding	1	703EH
U0-63	Reserved		
U0-64	Reserved		
U0-65	Upper limit of torque	0.1%	7041H
U0-66	Reserved		
U0-67	Reserved		
U0-68	Reserved		
U0-69	Reserved		
U0-70	Reserved		
U0-71	Reserved		
U0-72	Reserved		
U0-73	Motor selection		
U0-74	Reserved		
U0-75	Radiator temperature of inversion module	1°C	-
U0-76	Product No.	-	-
U0-77	Cumulative running time	1 hour	-
U0-78	Performance version number	-	-
U0-79	Functional version number	-	-
U0-80	Cumulative power-on time	1 hour	-
U0-81	Cumulative electricity consumption	1kW-h	-
U0-82	Low cumulative electricity consumption	0.1kW-h	-
U0-83	High cumulative electricity consumption	1kW-h	-
U0-84	Rated capacity of drive	0.1kW	-
U0-85	Rated current of drive	0.01A	-

U3 group (reserved)

Product and User Related Information

Product name: _____ Product model and specification: _____
 Product body (or packaging box) barcode (18 digits or 19 digits): _____
 Date of ex-factory: _____ Date of purchase: _____
 Buyer (User): _____ Tel: _____
 Address: _____
 Distributor (Agent): _____ Tel: _____
 Address: _____

Note 1: This card is the product warranty certificate, please keep it properly.
Note 2: The warranty period and warranty scope are shown in the operation instructions.
Only the cost will be charged for product maintenance after the warranty period expires or beyond the warranty scope.



CHNT

QC PASS

NV7 Series
 Drive
 EN/IEC 61800-3
 EN/IEC 61800-5-1

Check 05

Test date: Please see the packing

ZHEJIANG CHINT ELECTRICS CO., LTD.

CHINT

CHINT ELECTRICS

NVF7 Series
Drive
Operation Instructions

Zhejiang Chint Electrics Co., Ltd.

Add: No.1, CHINT Road, CHINT Industrial Zone, North Baixiang,
Yueqing, Zhejiang 325603, P.R.China

E-mail: global-sales@chint.com

Website: <http://en.chint.com>

0463V1651.EN

